

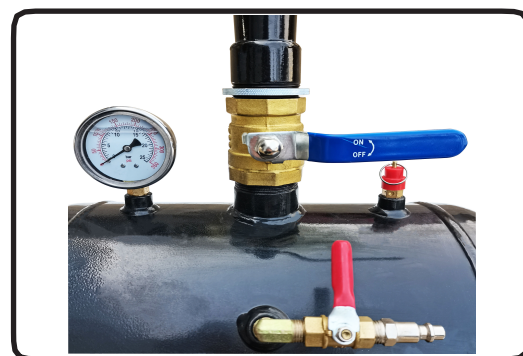

AIR BEAD SEATER BLASTER TIRE WHEEL PUMP

ITEM: 46023 / 46024 / 46028



OWNER'S MANUAL AND SAFETY INSTRUCTIONS

SAVE THIS MANUAL: KEEP THIS MANUAL FOR SAFETY WARNINGS, PRECAUTIONS, ASSEMBLY, OPERATING, INSPECTION, MAINTENANCE AND CLEANING PROCEDURES. WRITE THE PRODUCT'S SERIAL NUMBER ON THE BACK OF THE MANUAL NEAR THE ASSEMBLY DIAGRAM (OR MONTH AND YEAR OF PURCHASE IF PRODUCT HAS NO NUMBER).

FOR QUESTIONS PLEASE CALL OUR CUSTOMER SUPPORT: (909) 628 0880 MON-FRI 9AM TO 3PM PST



GENERAL SAFETY WARNINGS

Read all safety warnings and instructions. Failure to follow the warnings and instructions may result in serious injury. Save all warnings and instructions for future reference.

SAFETY

The warnings, precautions, and instructions discussed in this instruction manual cannot cover all possible conditions and situations that may occur. It must be understood by the operator that common sense and caution are factors which cannot be built into this product, but must be supplied by the operator. Read carefully and understand all ASSEMBLY AND OPERATION INSTRUCTIONS before operating. Failure to follow the safety rules and other basic safety precautions may result in serious personal injury.

- **Read and understand all instructions.** Failure to follow all instructions may result in serious injury or property damage.
- **DO NOT** allow persons to operate or assemble the product until they have read this manual and have developed a thorough understanding of how it works.
- **DO NOT modify this product in any way.** Unauthorized modification may impair the function and/or safety and could affect the life of the product. There are specific applications for which the product was designed.
- **Wear the proper personal protective equipment when necessary.** Use ANSI Z87.1 compliant safety goggles (not safety glasses) with side shields, or when needed, a face shield. Use a dust mask in dusty work conditions. Also use non-skid safety shoes, hard-hat, gloves, dust collection systems, and hearing protection when appropriate. This applies to all persons in the work area.
- **Keep children and bystanders away from the work area while operating the tool. DO NOT** allow children to handle the product.
- **WARNING:** Before initial use of the Bead Seater, it is necessary to purge the nozzle prior to first operation. This is to rid the machine of internal metal shavings that settle within the interior of the drum during storage and transportation from the factory.



SAVE THESE WARNINGS

BEAD SEATER PUMP MODEL

10GAL TIRE BEAD SEATER INFLATOR BLASTER ATV 165PSI PNEUMATIC #46023



5GAL TIRE BEAD SEATER INFLATOR BLASTER ATV 165PSI PNEUMATIC #46024



AIR BEAD SEATER 5GAL BLACK #46028



DIAGRAM AND SPECIFICATIONS

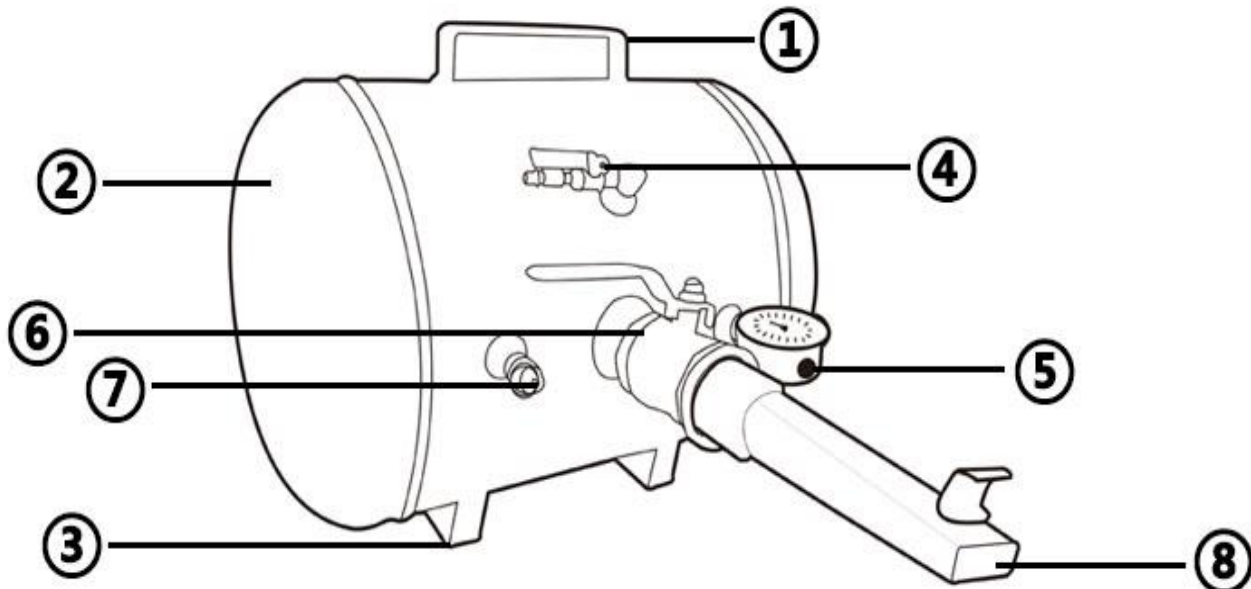

Item	Description	Number	Item	Description	Number
①	HANDLE	1	⑤	PRESSURE GAUGE	1
②	FUEL TANK	1	⑥	NIPPLE & DISCHARGE VALVE	1
③	MOUNTING FEET	2	⑦	SAFETY RELEASE VALVE	1
④	FILL VALVE	1	⑧	THREADED BARREL & LOCK NUT	1

TANK PRESSURE TABLE: Use the tank pressure table below as a guide for recommended starting pressures; individual circumstances may require higher or lower pressures. Increase pressure if the bead seating tool does not lift the tire bead far enough. Decrease pressure if the tire bead appears to seat at first and then falls off again.

VEHICLE TYPE	TIRE TYPES	SUGGESTED TANK PRESSURE	TIPS
ATV	16-650-8 22-11-8 25-12-9 24-9-11	40psi (2.7 bar)	Fit on stand with the stand in the highest position. Can be fitted with the calve at the bottom
LAWN TRACTOR	16-650-8 23-1050-12 26-12-12	40-50psi (2.7 - 3.4 bar)	Use the stand in the highest position
CAR	13" RIMS 14" RIMS	50 - 60psi (3.4 - 4.1 bar)	If difficult, do not place on the stand, lean the rim against it and ensure the valve is covered. Lubricate well.
4 X 4	15" RIMS 16" RIMS	60 - 80psi (4.1 - 5.4 bar)	Fit in vertical position. Lubricate well and ensure the valve is covered by the tire
TRUCK	11-22-5 18-22-5	100 (6.8 bar) 120 (8.2 bar)	Can be fitted vertically. Rotate the bead seating tool spout to the correct position
TRACTOR	UP TO 28" OVER 28"	100 psi (6.8 bar) 120 psi (8.2 bar)	Fit horizontally. Position the bottom bead on the rim, use the tire wedge
LARGE TRACTOR	TERRA TIRES 48-31-20 66-43-25	120 psi (8.2 bar)	Fit vertically. Roll tire until the back bead is in position

OPERATION

USING THE BEAD SEATER FOR HORIZONTAL POSITION FOR TIRE/WHEEL:

1. Position the wheel and tire flat on a tire stand so that the lower side wall is slightly off the floor.
2. Be sure to seat the lower tire bead on the bottom flange of the wheel.
3. Before attempting to seat the bead, make sure barrel flange is on top (on the same side as the air release handle) Rotate barrel to this position if necessary before proceeding.
4. Firmly hold the bead seater by the handle and position the barrel at an approximate 45 degree downward angle and place the barrel flange on the upper edge of the wheel rim opposite the tire valve into the opening between the tire and rim.
5. Take the other hand and quickly turn the air release valve to open, releasing air into the tire.
6. Once you have successfully seated the tire, connect an air supply line to the tire valve to complete tire inflation to correct pressure.

USING THE BEAD SEATER FOR VERTICAL POSITION FOR TIRE/WHEEL:

CAUTION: This method should only be used when there is a large gap between the wheel rim and tire bead or if the tire is too heavy.

1. Position the tire and wheel so that it is tilted slightly back and secure it with a tire wedge. Make sure the tire and wheel are supported away from the wall to be sure once inflated the tire and wheel do not fall forward, causing injury.
2. The back bead of the tire (furthest from operator) should be seated against the wheel rim trapping out any air. The front or wide flange of the wheel should be facing the operator with the tire valve stem positioned at the bottom of the tire.
3. Rotate the barrel so the barrel flange is underneath (on the opposite side if the air release handle).
4. Firmly hold the bead seater by the handle and position barrel at an approximate 45 degree downward angle and place the barrel flange on the edge of the wheel, opposite the tire valve, into the opening between the tire and rim.
5. Take the other hand and quickly turn the air release valve to open, releasing air into the tire.
6. Once you have successfully seated the tire, connect an air supply line to the tire valve to complete tire inflation to correct pressure.

USING THE BEAD SEATER FOR HORIZONTAL POSITION FOR TIRE/WHEEL

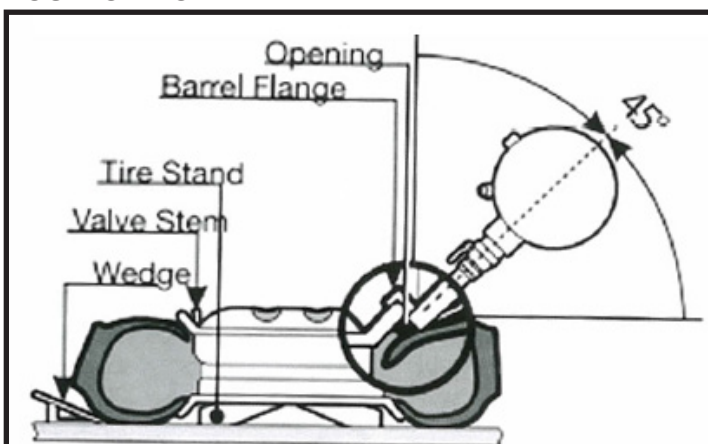

USING THE BEAD SEATER FOR VERTICAL POSITION FOR TIRE/WHEEL

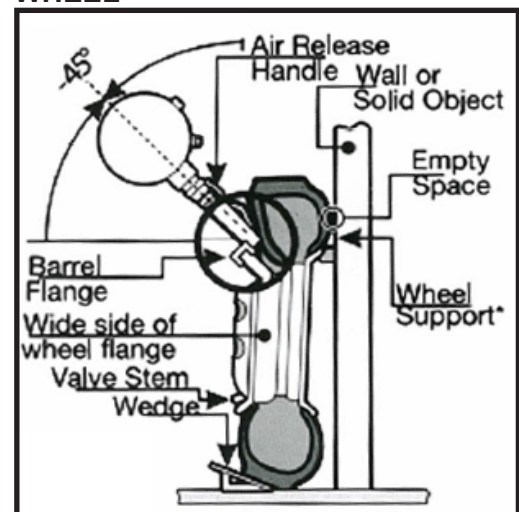

DIAGRAM AND SPECIFICATIONS

OPERATING THE AIR RELEASE HANDLE

Always turn the air release valve handle quickly and fully in one fluid motion during seating operation.

LUBRICATE

Lubricating all tire beads properly before using the bead seating tool is vital to proper functionality. Failing to lubricate beads may result in poor seating.

BEAD SEATING ANGLE

Always hold the bead seating tool at an angle so that the barrel points directly into the gap between the tire and rim, about 45 degrees from vertical or horizontal depending on tire wheel position. This is to ensure proper seating so air does not hit the outside of the tire pushing the tire away or the inside of the rim, not allowing air to enter the tire.

BEAD SEATING TOOL APPLICATION

The most effective position to apply the bead seating tool is opposite the tire valve and where the gap is the largest. This results in both sides of the tire receiving air supply and ensures that the maximum amount of air enters the tire, creating maximum lift. If a wedge has been properly used, the largest gap should be opposite the valve.

STORAGE

Always store the bead seater in a cool, dry place, hanging by the handle with the air release valve open to ensure any built-up moisture drains from the tank. This also protects the barrel and attachments from damage.

CONSTRUCTION

The barrel is threaded onto the air intake valve to allow for rotation. Before operating, the barrel must be orientated and tightened in accordance with the manual. Pressure gauge accuracy is +/- 10%.

AIR SUPPLY / CHANGING

The bead seater has been tested to ensure quality. The pressure release valve cannot exceed 165 psi (11 bar) Ensure that the bead seating tool is only charged immediately before use. The bead seating tool must be charged from a clean, oil-free, dry air supply and should only be charged from a low pressure airline system (up to 165 psi 11 bar). Never fill with anything other than air at ambient temperature.

HEARING PROTECTION

The barrel is threaded on to the air intake valve to allow for rotation. Check when operating the bead seating tool the barrel is orientated in accordance with the manual and the barrel had been tightened. Note the pressure gauge accuracy is +/- 10%.

NOISE SPECIFICATIONS

Assuming the bead seating tool is used on average of 6-10 times a day, Average noise level equivalent is approximately $L/AEq < 70dB$. Peak C weighted instantaneous sound pressure = $135dB = 112.46$ (measurements were taken discharging the bead seating tool into free air. The noise level is reduced when discharged at a tire and rim).

EYE PROTECTION

Always wear OSHA and ANSI Z87. 1-2003 approved safety goggles when operating this tool.

TIRE EXPLOSION RISK

Before using the bead seating tool on a tire or inflating any tire:

ALWAYS inspect the tire for damage.

ALWAYS ensure that any locking ring is secured in place.

ALWAYS use a safety cage for inflating large tires or tires at high pressure.

OPERATION AND MAINTENANCE

DO NOT over inflate the tire.

DO NOT inflate damaged tires.

OTHER USES:

DO NOT use the bead seater for any other purpose than what it is designed for.

DO NOT store or transport a charged tank.

DO NOT use it for dusting equipment nor people.

DO NOT discharge the bead seater towards anyone.

DO NOT clean a tire with a flammable solvent before using.

DO NOT subject the tank to any stress or impact that might weaken it.

NEVER STORE OR TRANSPORT A CHARGED BEAD SEATER. ALWAYS CHARGE BEFORE USE AND DISCHARGE AIR AFTER USE.

BE CAUTIOUS OF COMPRESSED AIR HAZARDS AND KEEP AWAY FROM FLAMMABLE MATERIALS AND VAPORS.

MAINTENANCE

Check the bead seating tool is regularly for damage or signs of wear and ensure the tank is inspected inside and out on a yearly basis.

NEVER TIGHTEN OR LOOSEN FITTINGS WHILE THE CYLINDER IS CHARGED.

Check for the following: Make sure there are no cracks in the tank or fittings. Make sure the barrel is not damaged or bent and there are no obstructions to the barrel.

DRAINING

Drain the bead seating tool regularly. To do this, hang the bead seater up with the barrel positioned downward and open the air release valve

AIR LINE SAFETY

An air line is designed to deliver maximum air volume and control by allowing the user to be hands free (from air line) during bead seating operation. Always use an appropriate air line for the type of tire you are inflating.

ACCESSORIES (NOT INCLUDED)

TIRE

A tire stand is designed to hold the wheel and tire in the best position for applying the bead seating tool is also available.

STAND

ACCESSORY

TIRE WEDGE

The tire wedge is used to support the tire to maximize bead contact with the rim. Place the wedge under the side of the tire near to the valve. This ensures that air entering through the valve goes into the tire and does not escape.

LOW PRESSURE AIR LINE

This ball-valve operated airline which enables the fitter to operate the airline connected to the tire valve stem easily while handling the bead seating tool. This improves the safety of the product as the operator is in full control of the air supply.

DISCLAIMER

PLEASE READ THE FOLLOWING CAREFULLY

THE MANUFACTURER AND/OR DISTRIBUTOR HAS PROVIDED THE PARTS LIST AND ASSEMBLY DIAGRAM IN THIS MANUAL AS A REFERENCE TOOL ONLY. NEITHER THE MANUFACTURER OR DISTRIBUTOR MAKES ANY REPRESENTATION OR WARRANTY OF ANY KIND TO THE BUYER THAT HE OR SHE IS QUALIFIED TO MAKE ANY REPAIRS TO THE PRODUCT, OR THAT HE OR SHE IS QUALIFIED TO REPLACE ANY PARTS OF THE PRODUCT. IN FACT, THE MANUFACTURER AND/OR DISTRIBUTOR EXPRESSLY STATES THAT ALL REPAIRS AND PARTS REPLACEMENTS SHOULD BE UNDERTAKEN BY CERTIFIED AND LICENSED TECHNICIANS, AND NOT BY THE BUYER. THE BUYER ASSUMES ALL RISK AND LIABILITY ARISING OUT OF HIS OR HER REPAIRS TO THE ORIGINAL PRODUCT OR REPLACEMENT PARTS THERETO, OR ARISING OUT OF HIS OR HER INSTALLATION OF REPLACEMENT PARTS THERETO.

Record Product's Serial Number Here: _____

Note: If product has no serial number, record month and year of purchase instead.

Note: Some parts are listed and shown for illustration purposes only and are not available individually as replacement parts.



Questions, Problems or Missing Parts?

Before returning to a retailer, our exceptional customer service is available to help.

Call Us: 909.628.0880

Hours of Operation: 9 to 4pm PST, Monday - Friday

Email: customer@xtremepowerusa.com

PRODUCT MADE IN CHINA