



## HIGH PRESSURE 650W AIRLESS PAINT SPRAY GUN

ITEM: 65157



### OWNER'S MANUAL AND SAFETY INSTRUCTIONS

SAVE THIS MANUAL: KEEP THIS MANUAL FOR SAFETY WARNINGS, PRECAUTIONS, ASSEMBLY, OPERATING, INSPECTION, MAINTENANCE AND CLEANING PROCEDURES. WRITE THE PRODUCT'S SERIAL NUMBER ON THE BACK OF THE MANUAL NEAR THE ASSEMBLY DIAGRAM (OR MONTH AND YEAR OF PURCHASE IF PRODUCT HAS NO NUMBER).

FOR QUESTIONS PLEASE CALL OUR CUSTOMER SUPPORT: (909) 628 4900 MON-FRI 9AM TO 3PM PST

# IMPORTANT SAFETY INFORMATION

**WARNING**

## GENERAL SAFETY WARNINGS

Read and thoroughly understand all instructions and safety information before assembling or operating this log splitter. Failure to do so may cause serious injury or death. **DO NOT** allow anyone to operate this device who has not read and understood this manual. **DO NOT** operate this device if you have doubts or questions concerning safe operation.

The warnings, precautions, and instructions discussed in this instruction manual cannot cover all possible conditions and situations that may occur. It must be understood by the operator that common sense and caution are factors which cannot be built into this product, but must be supplied by the operator.

- Keep the work area clean and well lighted. Cluttered benches and dark areas increase the risks of electric shock, fire, and injury to persons.
- Operate only in a well-ventilated area. Paint thinners and solvents may be harmful if inhaled.
- **DO NOT** operate the sprayer in explosive atmospheres, such as in the presence of flammable liquids, gases, or dust. The sprayer is able to create sparks resulting in the ignition of the dust or fumes.
- When operating a sprayer outdoors, use an extension cord suitable for outdoor use. Use of a cord suitable for outdoor use reduces the risk of electric shock.
- If operating a sprayer in a damp location is unavoidable, use a Ground Fault Circuit Interrupter (GFCI) protected supply. Use of a GFCI reduces the risk of electric shock.
- Stay alert. Watch what you are doing and use common sense when operating the tool. Do not use the tool while tired or under the influence of drugs, alcohol, or medication. A moment of inattention while operating the tool increases the risk of injury to persons.
- Dress properly. **DO NOT** wear loose clothing or jewelry. Contain long hair. Keep hair, clothing, and gloves away from moving parts. Loose clothes, jewelry, or long hair increases the risk of injury to persons as a result of being caught in moving parts.
- Avoid unintentional starting. Be sure the trigger is off before connecting to the power supply. **DO NOT** carry the sprayer with your finger on the trigger or connect the sprayer to the power supply with the trigger on.
- **DO NOT** overreach. Keep proper footing and balance at all times. Proper footing and balance enables better control of the tool in unexpected situations.
- Use safety equipment. Wear protective paint spraying gloves and a NIOSH-approved respirator during use. Non-skid safety shoes and a hard hat must be used for the applicable conditions.
- **ALWAYS** wear eye protection. Wear ANSI-approved safety goggles.
- **DO NOT** force the tool. Use the correct tool for the application. The correct tool will do the job better and safer at the rate for which it was designed.
- **DO NOT** use the sprayer if the switch does not turn it on and off. Any sprayer that cannot be controlled with the switch is dangerous and must be repaired.
- Disconnect the tool from the power source before making any adjustments, changing accessories, or storing the tool. Such preventive safety measures reduce the risk of starting the tool unintentionally.



# IMPORTANT SAFETY INFORMATION

- Store the tool when it is idle out of reach of children and other untrained persons. A tool is dangerous in the hands of untrained users.
- Check for misalignment or binding of moving parts, breakage of parts, and any other condition that affects the tool's operation. If damaged, have the tool serviced before using. Many accidents are caused by poorly maintained tools. There is a risk of bursting if the tool is damaged.
- Use only accessories that are identified by the manufacturer for the specific tool model. Use of an accessory not intended for use with the specific tool model, increases the risk of injury to persons.
- Tool service must be performed only by qualified repair personnel.
- When servicing a tool, use only identical replacement parts. Use only authorized parts.
- Use only lubricants supplied with the tool or specified by the manufacturer.
- **INJECTION HAZARD!** Although this paint gun is airless, it still puts out paint at a very high pressure. Through improper use, paint can be injected through a person's skin, leading to serious injury, possibly amputation. If paint is accidentally injected into someone's skin, contact a doctor immediately. **DO NOT** treat an injection injury as a simple cut. Injection can lead to amputation and requires immediate surgical treatment.
- **DO NOT** direct spray at people or animals. **DO NOT** place your hand in front of Spray Gun's nozzle or attempt to deflect paint spray with your hand during use. Gloves and clothing don't offer adequate protection from toxic paints, sealers, water-proofers, or stains.
- **DO NOT** spray flammable materials in vicinity of open flame or near ignition sources. Motors, electrical equipment, and controls can cause electrical arcs that will ignite a flammable gas or vapor. **DO NOT** store flammable liquids or gases in vicinity of this unit.
- **DO NOT** leave Paint Sprayer pressurized while unattended.
- **DO NOT** clean Spray Gun tip while it is still connected to paint hose.
- Keep the trigger and the electrical cord plug clean and paint-free.
- **DO NOT** run Paint Sprayer while empty. Damage to the unit may occur.
- **DO NOT** use Paint Sprayer to spray asbestos, metallic paints, glazes, red lead, cement, ground chalk, abrasive grainy paints containing lime, or bleach. These will damage the spray gun and void the warranty.
- Read all of the information concerning coating products and cleaning solvents. **DO NOT** use bleach, low-flash naphthalene, acetone, alcohol or toluene when cleaning Paint Sprayer equipment. **DO NOT** use chlorinated solvents (e.g. 1,1,1-trichloroethane and dichloromethane, also known as methylene chloride) to clean spray guns. Many spray guns contain aluminum, which reacts strongly to chlorinated solvents. Contact the solvent or coating manufacturer as needed regarding potential chemical reactions.
- **DO NOT** use solvents with flash points less than 70° F (21° C) to clean equipment. These may cause an explosion. Examples of acceptable cleaning solvents are water, mineral spirits and lacquer thinner. Note that some of these solvents may be inappropriate for certain kinds of paint; follow the paint supplier's recommendations.
- Industrial applications must follow OSHA requirements.
- Spraying hazardous materials may result in serious injury or death. Do not spray pesticide, acid, corrosive material, fertilizer, or toxic chemicals.
- People with pacemakers should consult their physician(s) before use. Electromagnetic fields in close proximity to heart pacemaker could cause pacemaker interference or pacemaker failure.

# IMPORTANT SAFETY INFORMATION

- Paints and solvents may be harmful or fatal if swallowed or inhaled. Avoid prolonged skin contact with solvents or paints as they will irritate skin. After any contact, immediately wash off exposed area with hot, soapy water.
- Maintain labels and nameplates on the sprayer. These carry important safety information.
- **WARNING:** Some dust created by power sanding, sawing, grinding, drilling, and other construction activities, contains chemicals known to the State of California to cause cancer and birth defects or other reproductive harm. Some examples of these chemicals are:• Lead from lead-based paints• Crystalline silica from bricks and cement or other masonry products• Arsenic and chromium from chemically treated lumberYour risk from these exposures varies, depending on how often you do this type of work. To reduce your exposure to these chemicals: work in a well ventilated area, and work with approved safety equipment, such as those dust masks that are specially designed to filter out microscopic particles. (California Health & Safety Code § 25249.5, et seq.)
- **WARNING:** The brass components of this product contain lead, a chemical known to the State of California to cause cancer and birth defects or other reproductive harm. (California Health & Safety Code § 25249.5, et seq.)
- **WARNING:** The cord of this product contains lead and/or di (2-ethylhexyl) phthalate (DEHP), chemicals known to the State of California to cause cancer, and birth defects or other reproductive harm. Wash hands after handling. (California Health & Safety Code § 25249.5, et seq.)
- **WARNING:** This product contains di (2-ethylhexyl) phthalate (DEHP), a chemical known to the State of California to cause cancer and birth defects or other reproductive harm. (California Health & Safety Code § 25249.5, et seq.)
- **WARNING: TO PREVENT ELECTRIC SHOCK AND DEATH FROM INCORRECT GROUNDING WIRE CONNECTION:** Check with a qualified electrician if you are in doubt as to whether the outlet is properly grounded. **DO NOT** modify the power cord plug provided with the tool. Never remove the grounding prong from the plug. **DO NOT** use the tool if the power cord or plug is damaged. If damaged, have it repaired by a service facility before use. If the plug will not fit the outlet, have a proper outlet installed by a qualified electrician.
- Sprayers marked with “Grounding Required” have a three wire cord and three prong grounding plug. The plug must be connected to a properly grounded outlet. If the sprayer should electrically malfunction or break down, grounding provides a low resistance path to carry electricity away from the user, reducing the risk of electric shock. (See 3-Prong Plug and Outlet.)
- The grounding prong in the plug is connected through the green wire inside the cord to the grounding system in the sprayer. The green wire in the cord must be the only wire connected to the sprayer’s grounding system and must never be attached to an electrically “live” terminal.
- The sprayer must be plugged into an appropriate outlet, properly installed and grounded in accordance with all codes and ordinances. The plug and outlet should look like those in the preceding illustration.

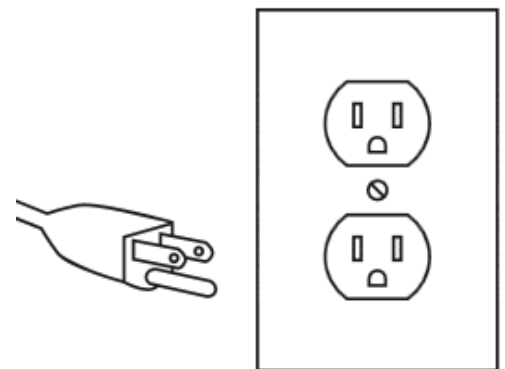

**3-Prong Plug and Outlet**

# IMPORTANT SAFETY INFORMATION

- Grounded sprayers require a three wire extension cord. Double Insulated sprayers can use either a two or three wire extension cord.
- As the distance from the supply outlet increases, you must use a heavier gauge extension cord. Using extension cords with inadequately sized wire causes a serious drop in voltage, resulting in loss of power and possible sprayer damage.
- As the distance from the supply outlet increases, you must use a heavier gauge extension cord. Using extension cords with inadequately sized wire causes a serious drop in voltage, resulting in loss of power and possible sprayer damage.

<b>RECOMMENDED MINIMUM WIRE GAUGE FOR EXTENSION CORDS* (120/240 VOLT)</b>					
<b>NAMEPLATE AMPERES (at full load)</b>	<b>EXTENSION CORD LENGTH</b>				
	<b>25'</b>	<b>50'</b>	<b>75'</b>	<b>100'</b>	<b>150'</b>
0 – 2.0	18	18	18	18	16
2.1 – 3.4	18	18	18	16	14
3.5 – 5.0	18	18	16	14	12
5.1 – 7.0	18	16	14	12	12
7.1 – 12.0	18	14	12	10	-
12.1 – 16.0	14	12	10	-	-
16.1 – 20.0	12	10	-	-	-

**TABLE A**      \* Based on limiting the line voltage drop to five volts at 150% of the rated amperes.



SAVE THESE WARNINGS

# PRODUCT INFORMATION

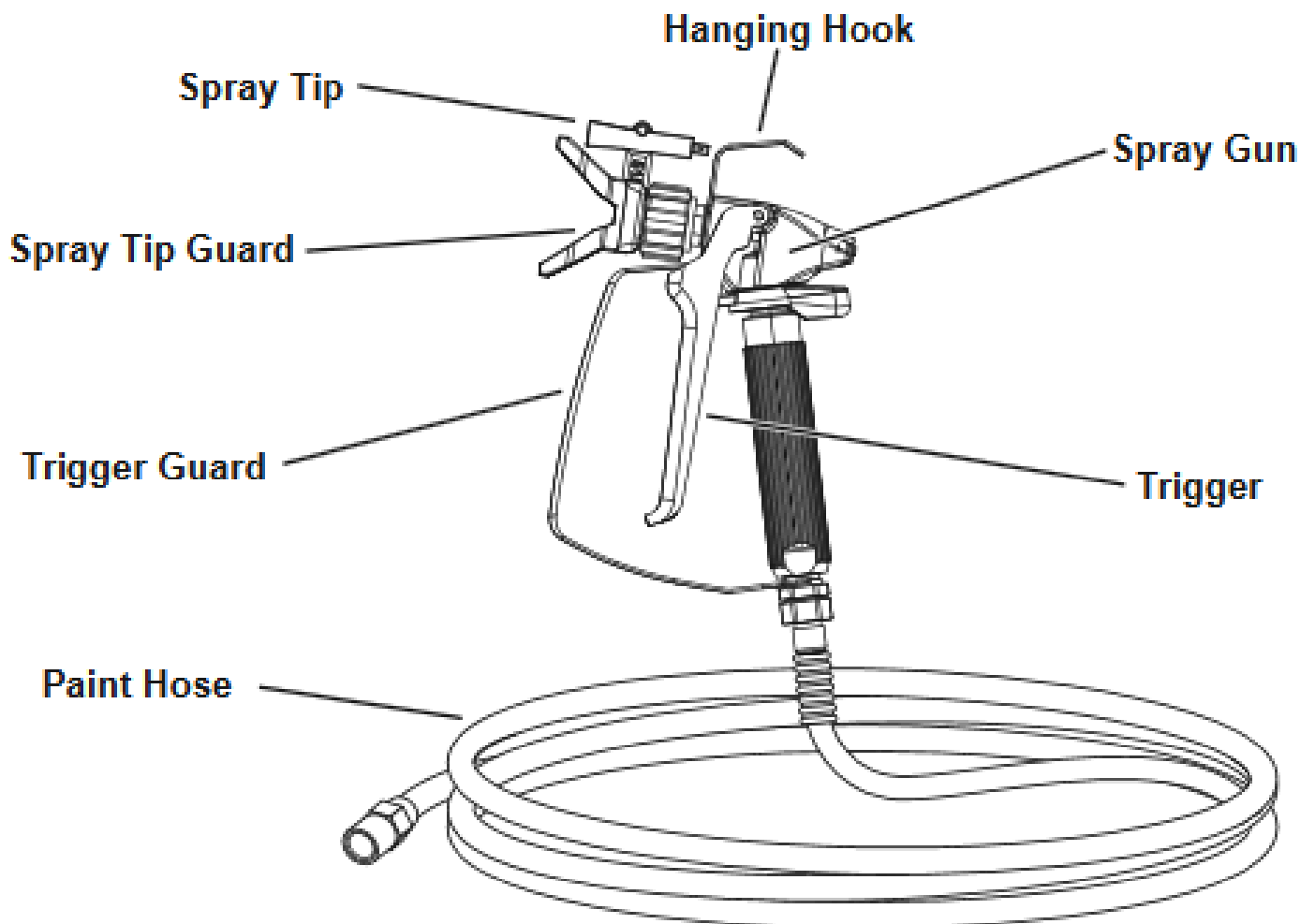
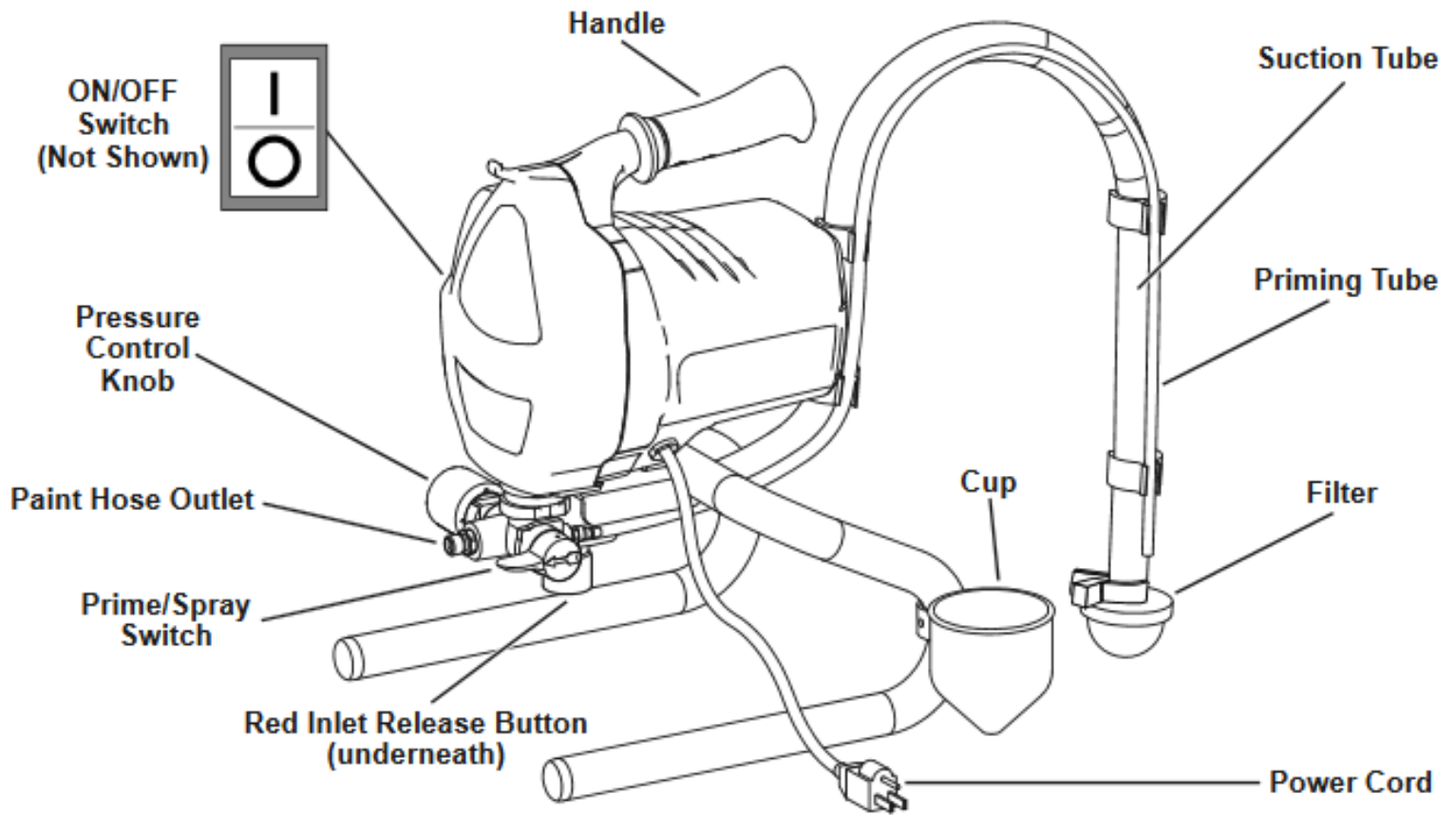

# IMPORTANT SAFETY INFORMATION

## Prime/Spray Switch

This switch toggles the unit between priming mode and spraying mode.

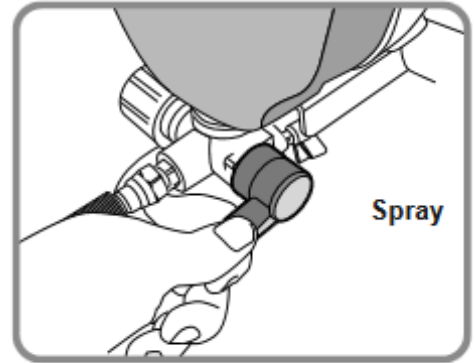
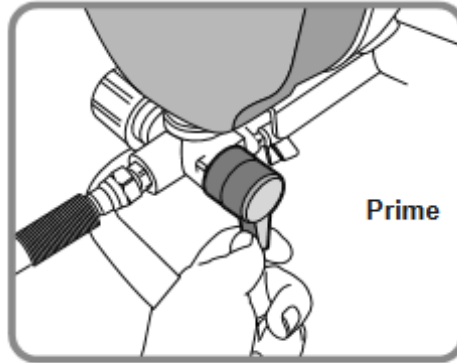

## Nozzle

The nozzle is reversible and removable to make cleaning and unclogging easier.

Turn to Spray position to use the spray gun.

Turn to Clean position to clean the nozzle.

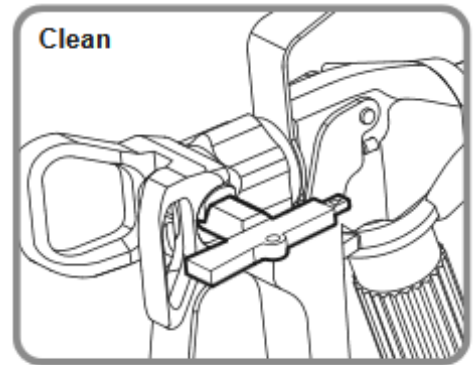
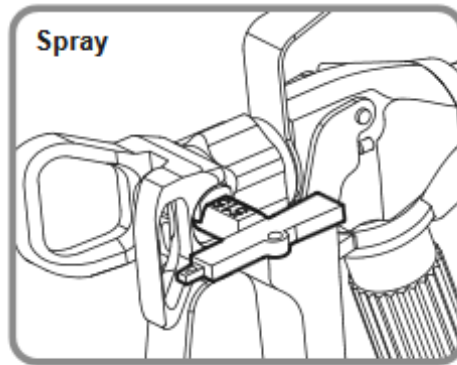

## Pressure Control Knob

The Pressure Control Knob can be adjusted for High Pressure Spraying, Low Pressure Spraying, Priming/Cleaning, or Rolling. Align the Pressure Control Knob with indicator on the Sprayer Housing to set the function.

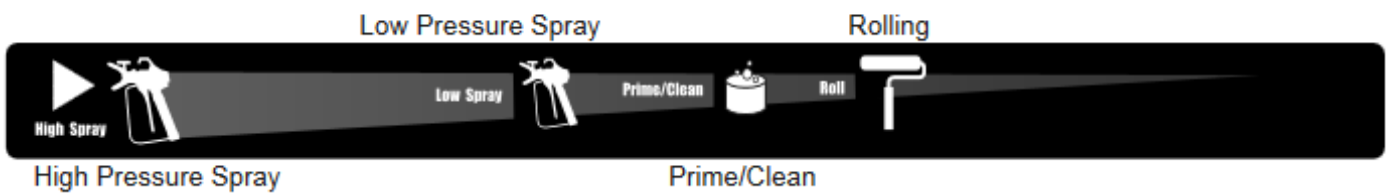
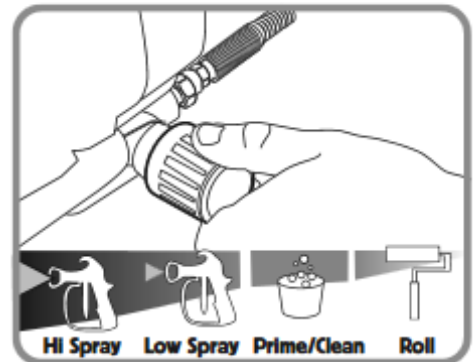

**NOTE:** Remove or cover objects that you want to protect from overspray (paint mist).

1. Attach Paint Hose to Paint Hose Outlet and tighten with wrench.

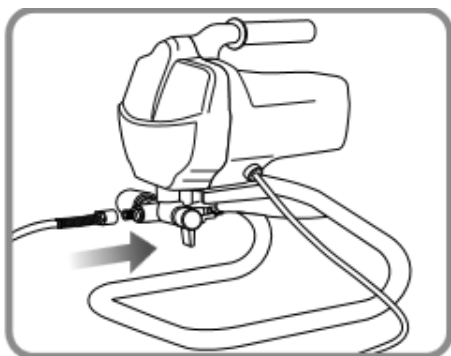

2. Turn Pressure Control Knob to Low Pressure Spray setting.

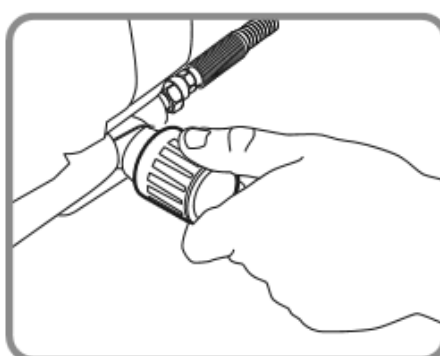

3. Attach Paint Hose to Paint Gun and tighten with two wrenches.

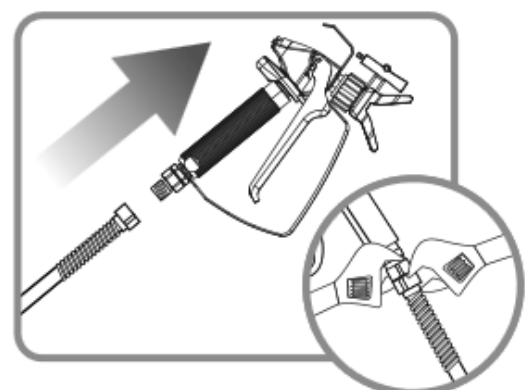

# OPERATION

## RELIEVE SPRAYER PRESSURE

1. Turn Power Switch OFF and unplug unit from outlet

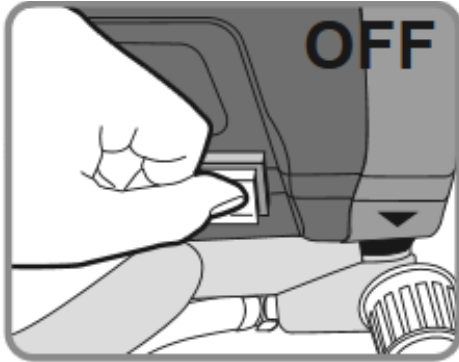

2. Switch Prime/Spray switch to Prime mode to safely release most pressure.

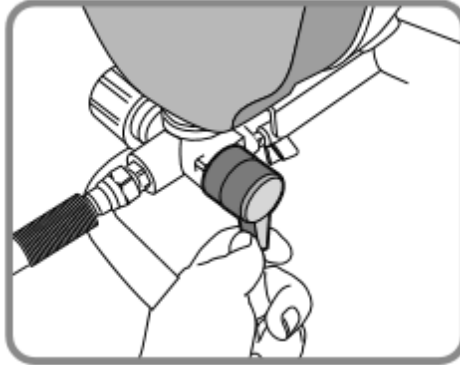

3. Point gun into paint pail and activate Sprayer Trigger to relieve any remaining pressure.

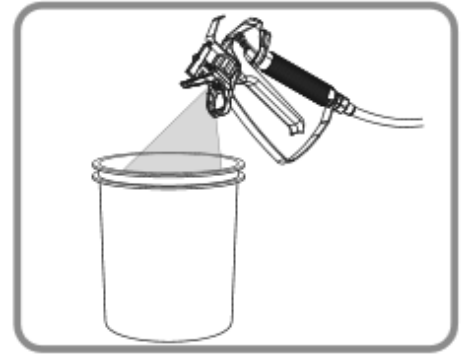

## PRIMING SPRAY GUN

**For Oil-based Paint:** Flush with mineral spirits followed by warm, clean water.

**For Water-based (Latex) Paint:** Flush with warm, clean water.

**WARNING! TO PREVENT FIRE:** When using mineral spirits, ground gun by holding it against a metal container while flushing.

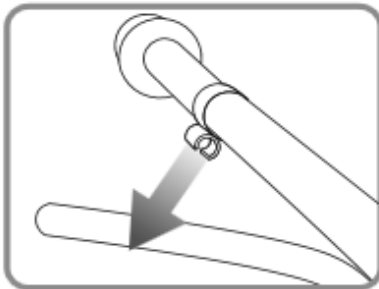

1. Separate smaller Priming Tube from Suction Tube.

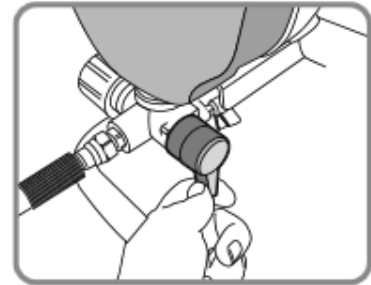

4. Turn Prime/Spray switch to Prime mode.

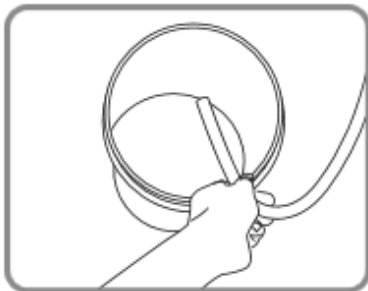

2. Place Priming Tube in waste bucket.

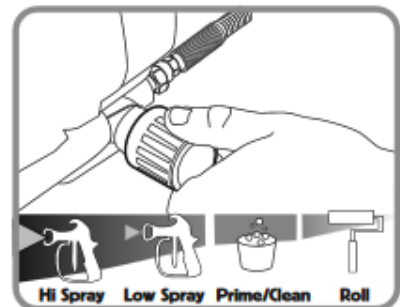

5. Adjust Pressure Control Knob to Prime/Clean setting.

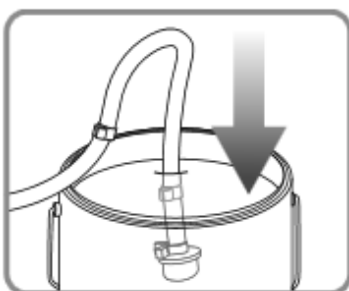

3. Submerge Suction Tube in water or flushing solvent.

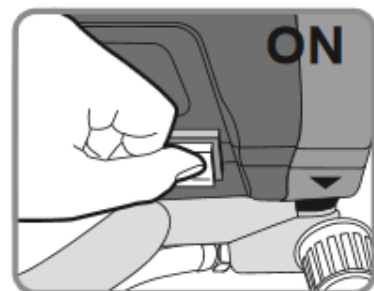

6. Plug in Sprayer and turn power ON.



# OPERATION

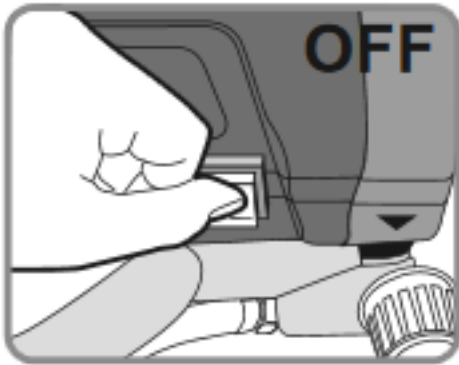

7. Sprayer will start pumping and water or flushing solvent as well as air bubbles will be purged from system. Let fluids discharge from Priming Tube into waste bucket for 30 to 60 seconds, then switch Power to OFF.

**IMPORTANT:** If solvent will not flow through hoses, try pressing the red inlet release button underneath the pump to loosen the inlet check ball.

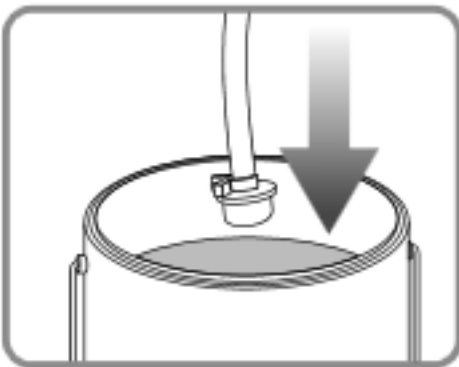

8. Remove Suction Tube from water or flushing solvent and submerge in paint pail.



9. Switch power ON.

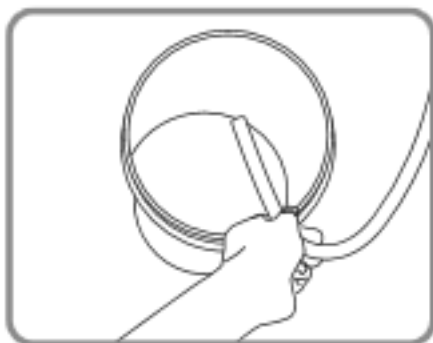

10. Paint should work itself from Suction Tube to Sprayer to Priming Tube until paint discharges from Priming Tube.

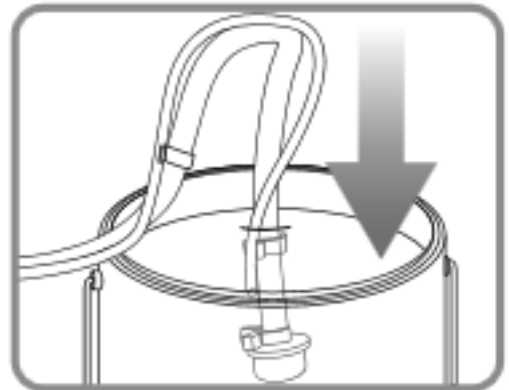

11. Switch power OFF. Remove the Priming Tube from the waste bucket and clip to Suction Tube and submerge in paint pail.

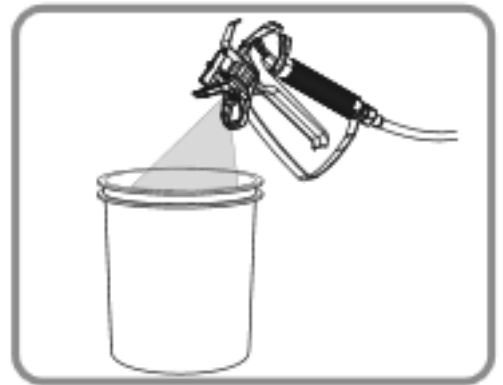

12. Switch power ON. Point gun into waste bucket and pull trigger.

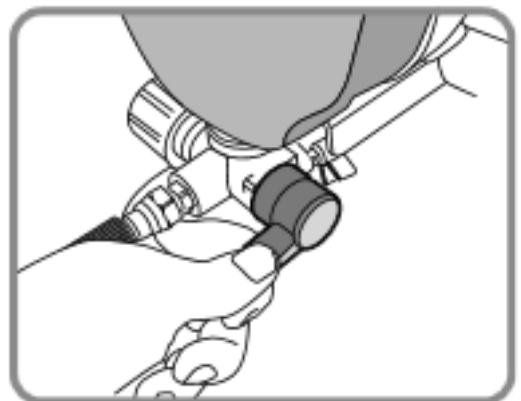

13. Turn Spray/Prime Switch to Spray mode and continue to spray into waste bucket.

14. Stop spraying. If the motor stops, the pump and tubes are primed. If it does not stop, repeat priming steps.

# OPERATION

**INJECTION HAZARD!** Although this paint gun is airless, it still puts out paint at a very high pressure. Through improper use, paint can be injected through a person's skin, leading to serious injury, possibly amputation. If paint is accidentally injected into someone's skin, contact a doctor immediately. Do not treat an injection injury as a simple cut. Injection can lead to amputation and requires immediate surgical treatment.

Before painting, ensure the Sprayer has been primed and verify that Nozzle Tip is aligned properly. Practice painting techniques on a scrap workpiece before painting your workpiece.

**NOTE:** Remove or cover objects that you want to protect from overspray and paint mist.

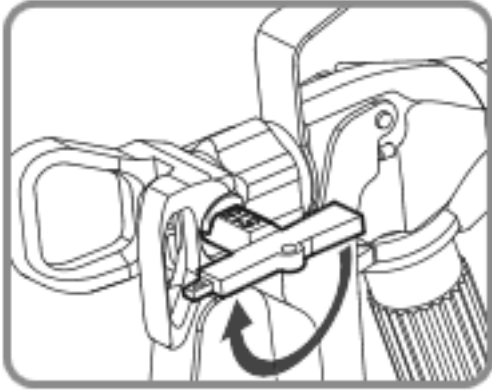

1. Once primed, adjust nozzle to Spray setting

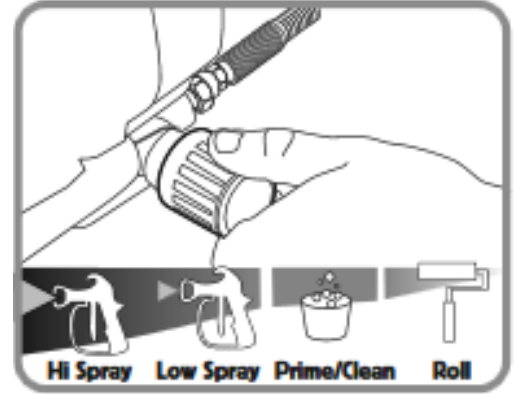

2. Start spraying at the lowest setting on the Pressure Control Knob and increase pressure as needed by turning clockwise to create a good spray pattern.

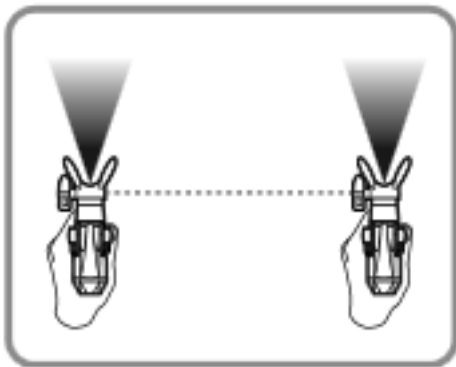

3. Keep gun straight and move arm across at a steady rate while staying one foot from the surface.

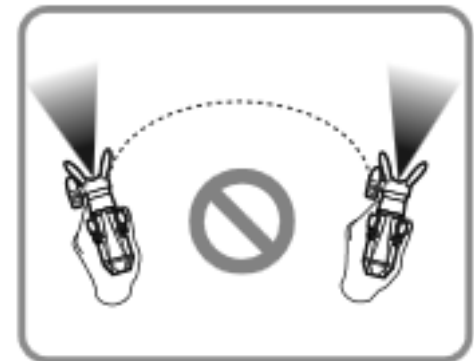

4. Do not fan the gun or paint will be uneven.

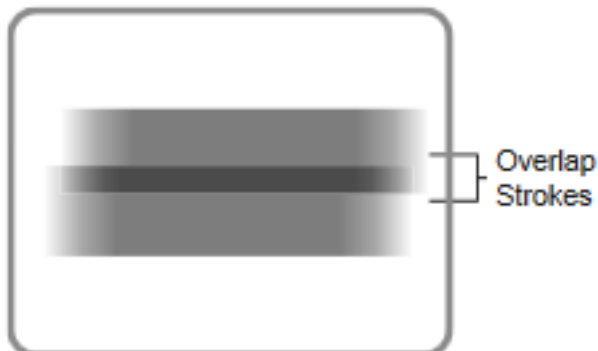

5. Overlap strokes by half. Always aim stroke at bottom edge of last stroke.

## CLEARING SPRAY TIP

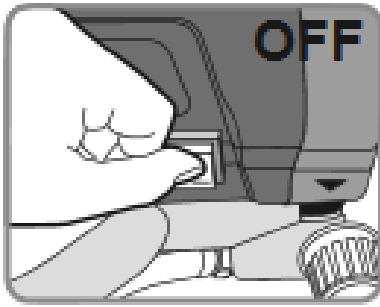

1. Switch Power to OFF

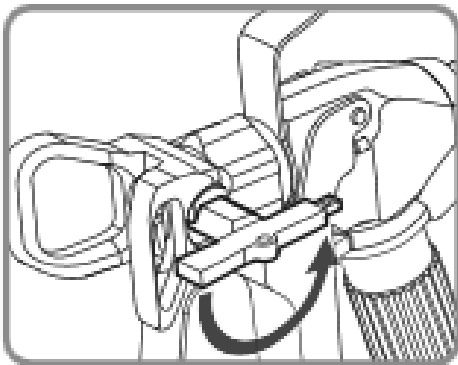

2. Adjust nozzle to clean setting

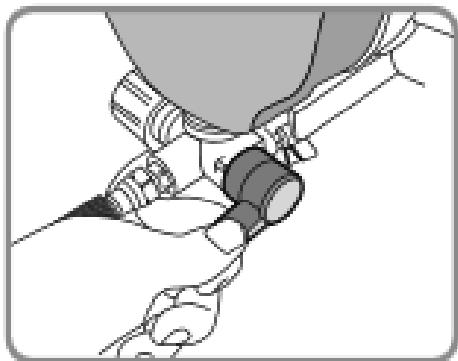

3. Turn spray/prime switch to spray mode

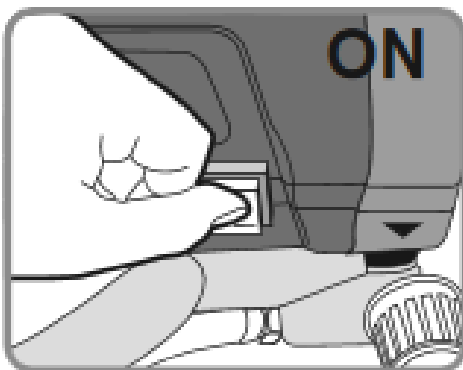

4. Turn power ON

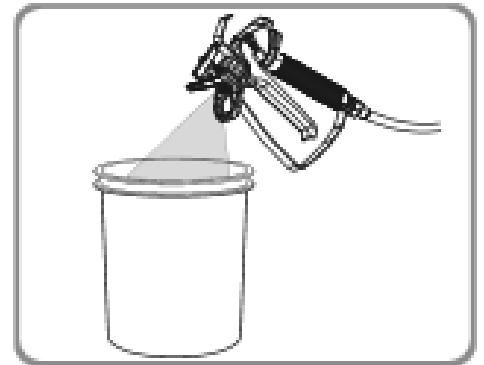

5. Spray into waste bucket until clog clears.

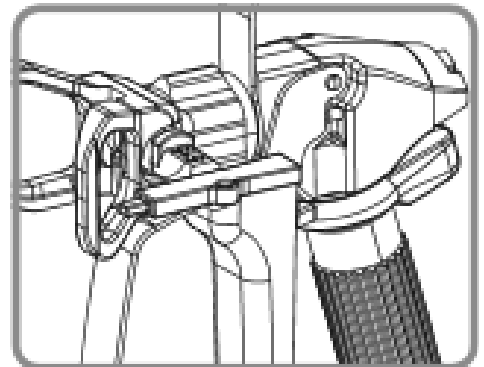

6. Release the trigger.

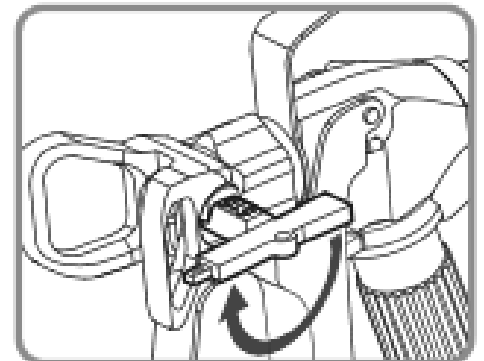

7. Adjust nozzle to Spray setting

## CLEANING

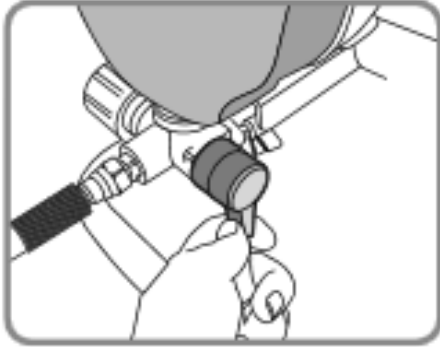

1. Turn power OFF and turn Prime/Spray switch to Prime mode to relieve pressure.

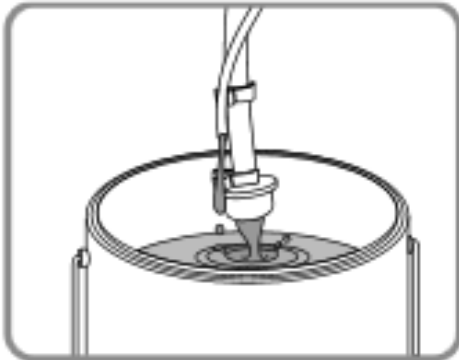

2. Drain paint from Tubes.

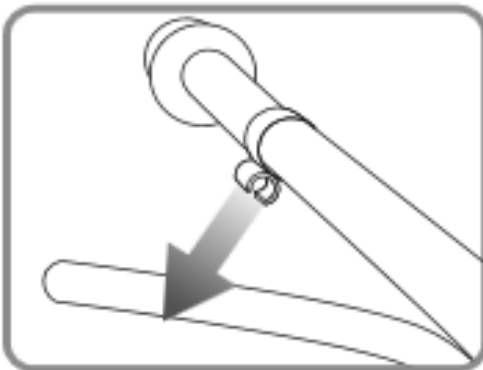

3. Separate tubes.

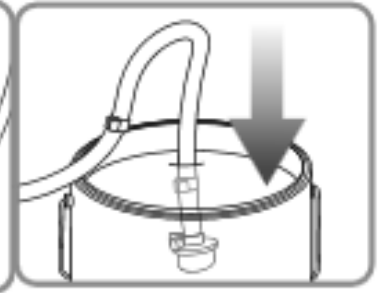

4. Place Priming Tube in empty waste bucket and submerge Suction Tube in water or flushing fluid.

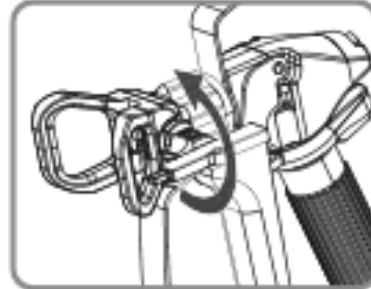

5. Unthread Spray Tip and remove.

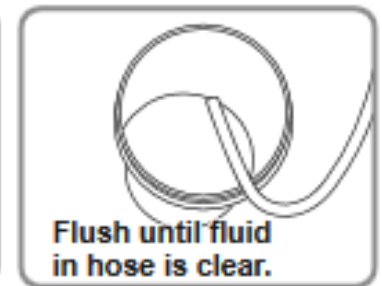

6. Plug in Sprayer and turn power ON. Sprayer will start pumping and water or flushing solvent as well as air bubbles will be purged from system. Let fluids discharge from Priming Tube into waste bucket until fluid is clear.

**TO PREVENT SERIOUS INJURY FROM ACCIDENTAL OPERATION:** Unplug the Sprayer from its electrical outlet before performing any inspection, maintenance, or cleaning procedures. requires immediate surgical treatment.

**TO PREVENT SERIOUS INJURY FROM TOOL FAILURE: DO NOT** use damaged equipment. If abnormal noise, vibration, or leaking air occurs, have the problem corrected before further use.

**Clean Sprayer immediately to prevent permanent damage.**

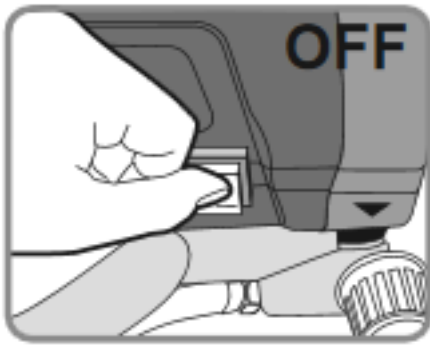

7. After fluid in Priming Tube is clear, switch Power to OFF.

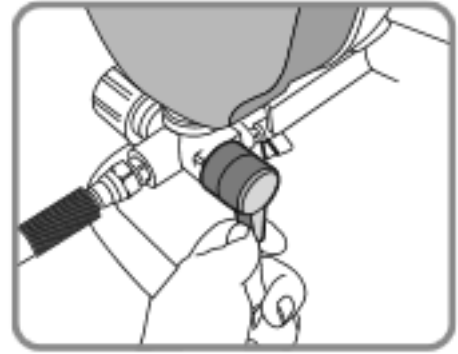

11. Turn to Prime mode.

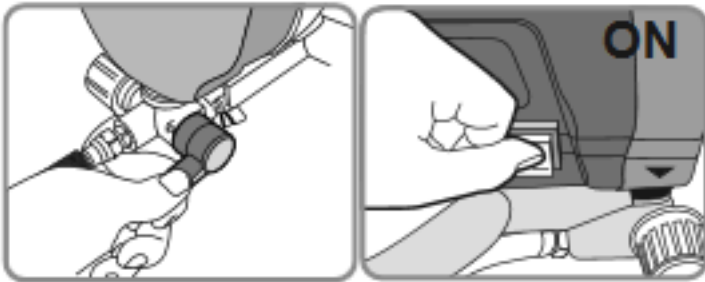

8. Turn to Spray mode and switch power to ON.



12. Continue to flush until clear.

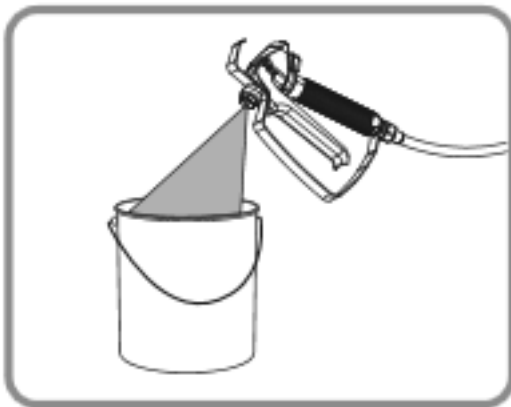

9. Spray paint into paint pail.

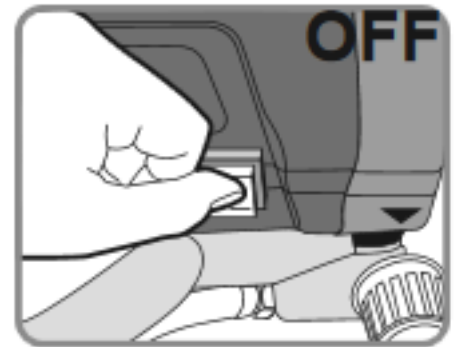

13. Release trigger, turn power OFF and turn Prime/Spray switch to Prime mode to relieve pressure.

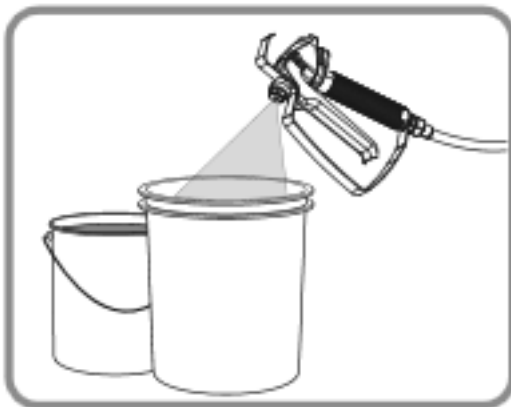

10. Change to waste bucket as paint thins.



14. Unscrew nut from housing, it is **behind** the swivel connector.

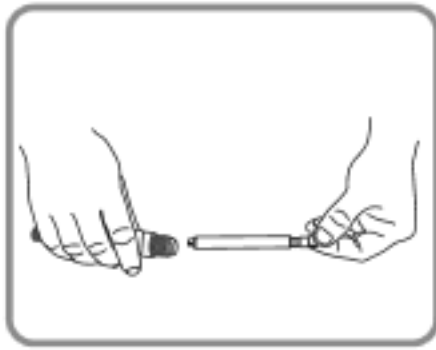

15. Remove filter.

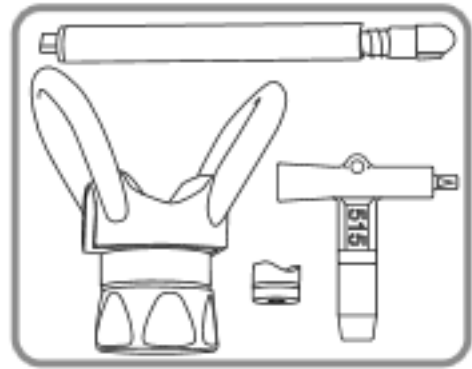

16. Clean all parts in warm, soapy water or flushing fluid with a bristled brush.

## Long-Term Storage

When cleaning for long term storage (more than 48 hours), it is very important that the Paint Sprayer is not stored with any water or water-based material left in the Pump, Hose, Tubes, or Spray Gun. This will corrode the product.

**IMPORTANT:** Clean the Sprayer before storage. Refer to Cleaning on page 16–17.

1. Remove paint hose if not already removed.

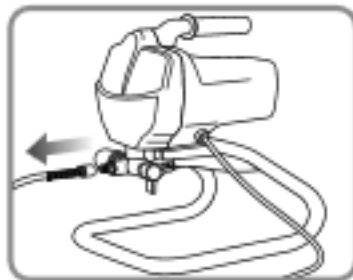

2. Turn the unit over and loosen the Clamps from both Tubes, then disconnect Tubes from the Pump Body.

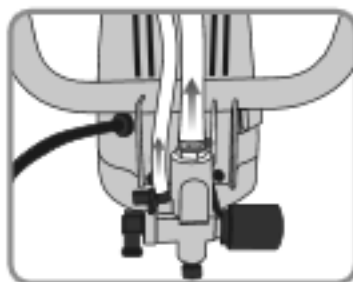

3. Add one ounce of light household oil or a pump storage product into each inlet.

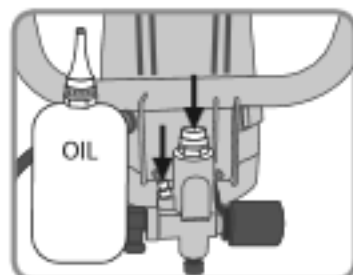

4. Turn Prime/Spray switch to Spray.

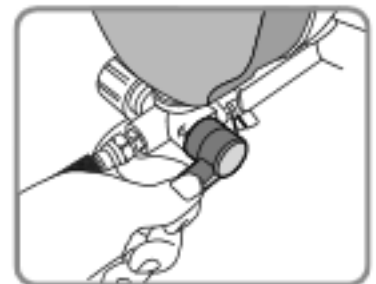

5. Turn Pressure Control Knob to Low/Spray.

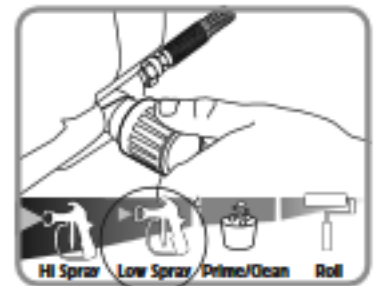

6. Hold a rag over the paint hose outlet.



7. Switch Power to ON for five seconds, then turn the power OFF.



# MAINTENANCE

8. Turn Prime/Spray switch to Prime, this will keep storage fluids in sprayer.

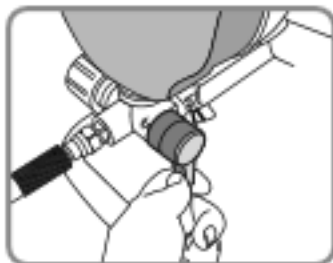

9. Replace the Tubes and secure with the Clamps.

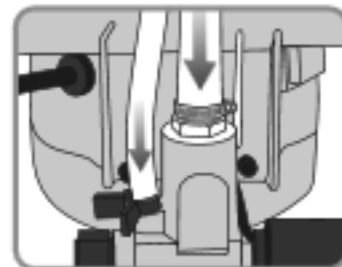

10. Wipe the sprayer with a clean cloth. Store in a clean dry location out of reach of children.

## Troubleshooting

Problem	Possible Causes	Likely Solutions
Pump will not prime.	Insufficient cleaning left input valve clogged.	Press the red inlet release button underneath the pump to loosen the inlet check ball.
Decreased output.	Obstructed trigger.	Clean around trigger to ensure movement.
Inconsistent paint flow, blobs and splatters.	1. Clogged Spray Tip or damaged/clogged Fluid Filter. 2. Contaminated paint.	1. Clean, adjust or replace Spray Tip or Fluid Filter. 2. Remove paint and filter it.
Paint surface is bumpy or has orange peel texture.	1. Paint is applied too thick. 2. Incorrect paint volume. 3. Paint gun too far from paint surface during spraying.	1. Paint must be thinned properly before spraying. 2. Adjust Fluid Control Knob. 3. Hold spray gun closer to surface during spraying.
Paint sags or runs.	1. Excess thinning of paint. 2. Paint applied too thick. 3. Paint gun too close to work surface. 4. Uneven or hesitant motion of spray gun. 5. Excess overlapping of each spray stroke.	1. Recheck paint viscosity. Add unmixed paint to thicken mixture. 2. Apply thinner coats, allowing paint to get tacky between coats. 3. Move spray gun further back from paint surface when applying paint. 4. Keep spray gun moving during painting. Hesitations can cause sags or runs. 5. Overlap each stroke to keep the coverage even, but be aware that you are adding coat thickness by overlapping.
Blotchy surface (blushing) or uneven color.	1. Paint dries too slowly. 2. Uneven paint application. 3. Work material absorbs paint unevenly.	1. Use less thinner or add a drier. 2. Start each stroke off the work material and overlap each stroke consistently. 3. Use a conditioner or sealer coat before applying the finish coat.
Spots on surface with light center (fish eyes).	1. Paint mixture too thin. 2. Improper primer or incompatible surface. 3. Surface contamination.	1. Add undiluted paint to thicken mixture. 2. Check manufacturer's recommendations for primer or compatible surfaces. 3. Clean surface thoroughly with thinner before applying paint.
Spots on surface with dark center (contamination).	1. Dust or dirt on surface. 2. Insufficiently sanded. 3. Raised grain.	1. Clean surface with compressed air or tack cloth before painting. 2. Sand wood to a sufficiently fine grit before painting. 3. Wipe wood surface with thinner to raise grain, then sand with fine grit to knock off "hairs".



Improper disposal of paint is against the law and a health and environmental hazard. Dispose of paint through local recycling facility.

# PARTS DIAGRAM

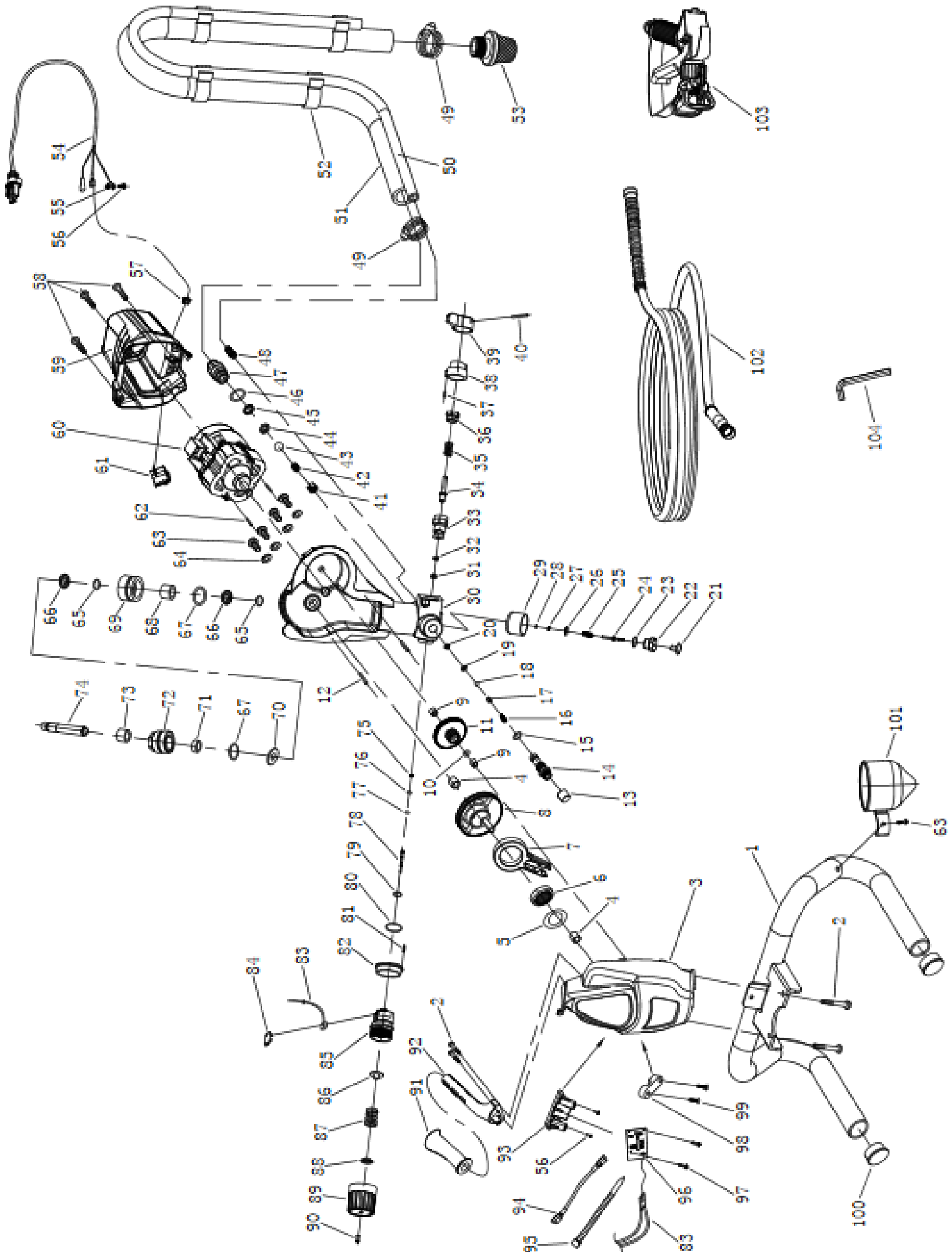



# PARTS LIST

Part	Description	Qty
1	Base Frame	1
2	Socket Bolt	4
3	Housing Cover	1
4	Brass Sleeve	2
5	Gasket	1
6	Bearing	1
7	Connecting Rod	1
8	Large Gear	1
9	Copper Sleeve	2
10	Small Gear Washer	1
11	Small Gear	1
12	Pin (5x12)	2
13	Dust Cover	1
14	Paint Outlet	1
15	O-Ring (10x1.8)	1
16	Output Spring	1
17	Output Spring Seat	1
18	Steel Ball (6.4)	1
19	Output Valve Seat	1
20	Output Valve Seat Gasket	1
21	Inlet Release Button	1
22	Lock Nut	1
23	O-Ring (12x1.8)	1
24	Bar	1
25	Spring	1
26	Copper Gasket	1
27	Shield Ring	1
28	O-Ring (2.4x1.8)	1
29	Sleeve	1
30	Pump Body	1
31	Gasket	1
32	Insert Block	1
33	Pressure Relief Valve	1
34	Pressure Relief Rod	1
35	Pressure Relief Spring	1
36	Pressure Relief Spring Seat	1
37	Pin (3x12)	1
38	Control Valve Seat	1
39	Prime/Spray Valve	1
40	Pin (2.5x25)	1
41	Feed Valve Spring Seat	1
42	Feed Valve Spring	1
43	Steel Ball (12.7)	1
44	Feed Valve Seat	1
45	Washer	1
46	O-Ring (17x1.8)	1
47	Paint Input Adapter	1
48	Priming Tube Connector	1
49	Clamp	2
50	Priming Tube	1
51	Suction Tube	1
52	Clip	4

Part	Description	Qty
53	Filter	1
54	Power Cord	1
55	Washer	1
56	Screw	3
57	Power Cord Retainer	1
58	Socket Bolt	3
59	Motor Housing	1
60	Motor Assembly	1
61	Power Switch	1
62	Pin (3x12)	2
63	Bolt	5
64	Washer	4
65	O-Ring (12.5x2.65)	2
66	Shield Ring	2
67	O-Ring (22.5x1.8)	2
68	Brass Sleeve	1
69	Plunger Sleeve	1
70	Pressure Plate	1
71	Felt Washer	1
72	Connector	1
73	Brass Guide Bushing	1
74	Piston	1
75	Lock Sleeve	1
76	Seal	1
77	Seal	1
78	Pressure Control Pin	1
79	O-Ring (8x1.8)	1
80	O-Ring (27x2.65)	1
81	Bolt	2
82	Pressure Seal Cover	1
83	Micro Switch	1
84	Micro Switch Cover	1
85	Pressure Control Switch	1
86	Pressure Adjusting Spring Seat	1
87	Pressure Adjusting Spring	1
88	Spring Pusher	1
89	Pressure Control Knob	1
90	Pressure Control Knob Bolt	1
91	Handle Grip	1
92	Handle	1
93	PCB Support	1
94	Wire Connector	1
95	Cable Tie	1
96	PCB Assembly	1
97	Screw	2
98	Power Cord Clamp	1
99	Screw	2
100	Base Frame End Cap	2
101	Cup	1
102	Paint Hose	1
103	Spray Gun	1
104	Hex Key	1

# OF NOTE

## PLEASE READ THE FOLLOWING CAREFULLY

THE MANUFACTURER AND/OR DISTRIBUTOR HAS PROVIDED THE PARTS LIST AND ASSEMBLY DIAGRAM IN THIS MANUAL AS A REFERENCE TOOL ONLY. NEITHER THE MANUFACTURER OR DISTRIBUTOR MAKES ANY REPRESENTATION OR WARRANTY OF ANY KIND TO THE BUYER THAT HE OR SHE IS QUALIFIED TO MAKE ANY REPAIRS TO THE PRODUCT, OR THAT HE OR SHE IS QUALIFIED TO REPLACE ANY PARTS OF THE PRODUCT. IN FACT, THE MANUFACTURER AND/OR DISTRIBUTOR EXPRESSLY STATES THAT ALL REPAIRS AND PARTS REPLACEMENTS SHOULD BE UNDERTAKEN BY CERTIFIED AND LICENSED TECHNICIANS, AND NOT BY THE BUYER. THE BUYER ASSUMES ALL RISK AND LIABILITY ARISING OUT OF HIS OR HER REPAIRS TO THE ORIGINAL PRODUCT OR REPLACEMENT PARTS THERETO, OR ARISING OUT OF HIS OR HER INSTALLATION OF REPLACEMENT PARTS THERETO.

**Record Product's Serial Number Here:** \_\_\_\_\_

**Note:** If product has no serial number, record month and year of purchase instead.

**Note:** Some parts are listed and shown for illustration purposes only and are not available individually as replacement parts.



## SAVE THESE INSTRUCTIONS.

The material in this manual is for informational purposes only. The product(s) it describes are subject to change without prior notice, due to the manufacturer's continuous development program. Stark Tools makes no representations or warranties with respect to this manual or with respect to the products described herein. Stark Tools shall not be liable for any damages, losses, costs or expenses, direct, indirect or incidental, consequential or special, arising out of, or related to the use of this material or the products described herein.

## Questions, problems, missing parts?



Before returning to your retailer, our exceptional customer service is here to help.

Call Us: 909.628.4900

Email Us: [info@starktoolsusa.com](mailto:info@starktoolsusa.com)

Hours of Operation: 9am - 4pm (Monday - Friday)

**PRODUCT MADE IN CHINA**