

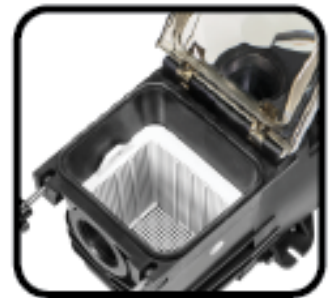

1HP 6.5" SINGLE SPEED INGROUND POOL PUMP

ITEM # 75405



OWNER'S MANUAL AND SAFETY INSTRUCTIONS

SAVE THIS MANUAL. KEEP THIS MANUAL FOR SAFETY WARNINGS, PRECAUTIONS, ASSEMBLY, OPERATION, INSPECTION, MAINTENANCE AND CLEANING PROCEDURES. WRITE THE PRODUCT'S SERIAL NUMBER ON THE BACK OF THE MANUAL, OR THE MONTH AND YEAR OF PURCHASE IF PRODUCT HAS NO SERIAL NUMBER

FOR QUESTIONS, PLEASE CALL CUSTOMER SERVICE: 909.628.0880

IMPORTANT PUMP WARNING AND SAFETY INSTRUCTIONS



IMPORTANT NOTICE

This guide provides installation and operation instructions for the IntelliFlo® Variable Speed Pump. Consult Pentair with any questions regarding this equipment. **Attention Installer:** This guide contains important information about the installation, operation and safe use of this product. This information should be given to the owner and/or operator of this equipment after installation or left on or near the heat pump. **Attention User:** This manual contains important information that will help you in operating and maintaining this product. Please retain it for future reference.

READ AND FOLLOW ALL INSTRUCTIONS

SAVE THESE INSTRUCTIONS



This is the safety alert symbol. When you see this symbol on your system or in this manual, look for one of the following signal words and be alert to the potential for personal injury.

⚠ DANGER Warns about hazards that can cause death, serious personal injury, or major property damage if ignored.

⚠ WARNING Warns about hazards that may cause death, serious personal injury, or major property damage if ignored.

⚠ CAUTION Warns about hazards that may or can cause minor personal injury or property damage if ignored.

NOTE indicates special instructions not related to hazards. Carefully read and follow all safety instructions in this manual and on equipment. Keep safety labels in good condition; replace if missing or damaged.

When installing and using this electrical equipment, basic safety precautions should always be followed, include the following:

⚠ WARNING Do not permit children to use this product.

⚠ WARNING **Risk of Electrical Shock.** Connect only to a branch circuit protected by a ground-fault circuit-interrupter (GFCI). Contact a qualified electrician if you cannot verify that the circuit is protected by a GFCI.

⚠ WARNING This unit must be connected only to a supply circuit that is protected by a ground-fault circuit-interrupter (GFCI). Such a GFCI should be provided by the installer and should be tested on a routine basis. To test the GFCI, push the test button. The GFCI should interrupt power. Push the reset button. Power should be restored. If the GFCI fails to operate in this manner, the GFCI is defective. If the GFCI interrupts power to the pump without the test button being pushed, a ground current is flowing, indicating the possibility of an electric shock. Do not use this pump. Disconnect the pump and have the problem corrected by a qualified service representative before using.

⚠ WARNING This pump is for use with permanent swimming pools and may also be used with hot tubs and spas if so marked. Do not use with storable pools. A permanently-installed pool is constructed in or on the ground or in a building such that it cannot be readily disassembled for storage. A storable pool is constructed so that it is capable of being readily disassembled for storage and reassembled to its original integrity.

⚠ CAUTION This pump is for use with permanent swimming pools and may also be used with hot tubs and spas if so marked. Do not use with storable pools. A permanently-installed pool is constructed in or on the ground or in a building such that it cannot be readily disassembled for storage. A storable pool is constructed so that it is capable of being readily disassembled for storage and reassembled to its original integrity.

General Warnings

- Never open the inside of the drive motor enclosure. There is a capacitor bank that holds a 230 VAC charge even when there is no power to the unit.
- The pump is not submersible.
- The pump is capable of high flow rates; use caution when installing and programming to limit pumps performance potential with old or questionable equipment.
- Code requirements for the electrical connection differ from state to state. Install equipment in accordance with the National Electrical Code and all applicable local codes and ordinances.
- Before servicing the pump; switch OFF power to the pump by disconnecting the main circuit to the pump.
- This appliance is not intended for use by persons (including children) of reduced physical, sensory or mental capabilities, or lack of experience and knowledge, unless they have been given supervision or instruction concerning the use of the appliance by a person responsible for their safety.

⚠ DANGER FAILURE TO FOLLOW ALL INSTRUCTIONS AND WARNINGS CAN RESULT IN SERIOUS BODILY INJURY OR DEATH. **THIS PUMP SHOULD BE INSTALLED AND SERVICED ONLY BY A QUALIFIED POOL SERVICE PROFESSIONAL. INSTALLERS, POOL OPERATORS AND OWNERS MUST READ THESE WARNINGS AND ALL INSTRUCTIONS IN THE OWNER'S MANUAL BEFORE USING THIS PUMP. THESE WARNINGS AND THE OWNER'S MANUAL MUST BE LEFT WITH THE POOL OWNER.**

⚠ DANGER SUCTION ENTRAPMENT HAZARD: STAY OFF THE MAIN DRAIN AND AWAY FROM ALL SUCTION OUTLETS!

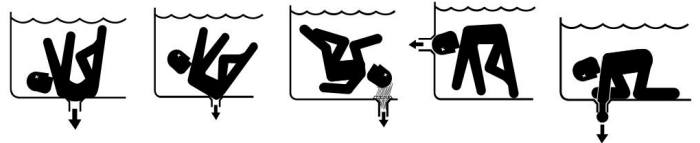

THIS PUMP PRODUCES HIGH LEVELS OF SUCTION AND CREATES A STRONG VACUUM AT THE MAIN DRAIN AT THE BOTTOM OF THE BODY OF WATER. THIS SUCTION IS SO STRONG THAT IT CAN TRAP ADULTS OR CHILDREN UNDER WATER IF THEY COME IN CLOSE PROXIMITY TO A DRAIN OR A LOOSE OR BROKEN DRAIN COVER OR GRATE.

THE USE OF UNAPPROVED COVERS OR ALLOWING USE OF THE POOL OR SPA WHEN COVERS ARE MISSING, CRACKED OR BROKEN CAN RESULT IN BODY OR LIMB ENTRAPMENT, HAIR ENTANGLEMENT, BODY ENTRAPMENT, EVisCERATION AND/OR DEATH. The suction at a drain or outlet can cause:

Limb Entrapment: When a limb is sucked or inserted into an opening resulting in a mechanical bind or swelling. This hazard is present when a drain cover is missing, broken, loose, cracked or not properly secured.

Hair Entanglement: When the hair tangles or knots in the drain cover, trapping the swimmer underwater. This hazard is present when the flow rating of the cover is too small for the pump or pumps.

Body Entrapment: When a portion of the body is held against the drain cover trapping the swimmer underwater. This hazard is present when the drain cover is missing, broken or the cover flow rating is not high enough for the pump or pumps.

Evisceration/Disembowelment: When a person sits on an open pool (particularly a child wading pool) or spa outlet and suction is applied directly to the intestines, causing severe intestinal damage. This hazard is present when the drain cover is missing, loose, cracked, or not properly secured.

IMPORTANT PUMP WARNING AND SAFETY INSTRUCTIONS

Mechanical Entrapment: When jewelry, swimsuit, hair decorations, finger, toe or knuckle is caught in an opening of an outlet or drain cover. This hazard is present when the drain cover is missing, broken, loose, cracked, or not properly secured.

NOTE: ALL SUCTION PLUMBING MUST BE INSTALLED IN ACCORDANCE WITH THE LATEST NATIONAL AND LOCAL CODES, STANDARDS AND GUIDELINES.

WARNING TO MINIMIZE THE RISK OF INJURY DUE TO SUCTION ENTRAPMENT HAZARD:

- A properly installed and secured ANSI/ASME A112.19.8 approved anti-entrapment suction cover must be used for each drain.
- Each suction cover must be installed at least three (3') feet apart, as measured from the nearest point to nearest point.
- Regularly inspect all covers for cracks, damage and advanced weathering.
- If a cover becomes loose, cracked, damaged, broken or is missing, replace with an appropriate certified cover.
- Replace drain covers as necessary. Drain covers deteriorate over time due to exposure to sunlight and weather.
- Avoid getting hair, limbs or body in close proximity to any suction cover, pool drain or outlet.
- Disable suction outlets or reconfigure into return inlets.

WARNING A clearly labeled emergency shut-off switch for the pump must be in an easily accessible, obvious place. Make sure users know where it is and how to use it in case of emergency.

The Virginia Graeme Baker (VGB) Pool and Spa Safety Act creates new requirements for owners and operators of commercial swimming pools and spas.

Commercial pools or spas constructed on or after December 19, 2008, shall utilize:

(A) A multiple main drain system without isolation capability with suction outlet covers that meet ASME/ANSI A112.19.8a Suction Fittings for Use in Swimming Pools, Wading Pools, Spas, and Hot Tubs and either:

- (i) A safety vacuum release system (SVRS) meeting ASME/ANSI A112.19.17 Manufactured Safety Vacuum Release systems (SVRS) for Residential and Commercial Swimming Pool, Spa, Hot Tub, and Wading Pool Suction Systems and/or ASTM F2387 Standard Specification for Manufactured Safety Vacuum Release Systems (SVRS) for Swimming pools, Spas and Hot Tubs or
- (ii) A properly designed and tested suction-limiting vent system or
- (iii) An automatic pump shut-off system.

Commercial pools and spas constructed prior to December 19, 2008, with a single submerged suction outlet shall use a suction outlet cover that meets ASME/ANSI A112.19.8a and either:

- (A) A SVRS meeting ASME/ANSI A112.19.17 and/or ASTM F2387, or
- (B) A properly designed and tested suction-limiting vent system, or
- (C) An automatic pump shut-off system, or
- (D) Disabled submerged outlets, or
- (E) Suction outlets shall be reconfigured into return inlets.

For Installation of Electrical Controls at Equipment Pad (ON/OFF Switches, Timers and Automation Load Center)

CAUTION Install all electrical controls at equipment pad, such as on/off switches, timers, and control systems, etc. to allow the operation (startup, shut-down, or servicing) of any pump or filter so the user does not place any portion of his/her body over or near the pump strainer lid, filter lid or valve closures. This installation should allow the user enough space to stand clear of the filter and pump during system start-up, shut down or servicing of the system filter.



DANGER

HAZARDOUS PRESSURE: STAND CLEAR OF PUMP AND FILTER DURING START UP



Circulation systems operate under high pressure. When any part of the circulating system (i.e. locking ring, pump, filter, valves, etc.) is serviced, air can enter the system and become pressurized.

Pressurized air can cause the pump housing cover filter lid and valves to violently separate which can result in severe personal injury or death. Filter tank lid and strainer cover must be properly secured to prevent violent separation. Stand clear of all circulation system equipment when turning on or starting up pump.

Before servicing equipment, make note of the filter pressure. Be sure that all controls are set to ensure the system cannot inadvertently start during service. Turn off all power to the pump. **IMPORTANT: Place filter manual air relief valve in the open position and wait for all pressure in the system to be relieved.**

Before starting the system, fully open the manual air relief valve and place all system valves in the "open" position to allow water to flow freely from the tank and back to the tank. Stand clear of all equipment and start the pump.

IMPORTANT: Do not close filter manual air relief valve until all pressure has been discharged from the valve and a steady stream of water appears. Observe filter pressure gauge and be sure it is not higher than the pre-service condition.

General Installation Information

- All work must be performed by a qualified service professional, and must conform to all national, state, and local codes.
- Install to provide drainage of compartment for electrical components.
- These instructions contain information for a variety of pump models and therefore some instructions may not apply to a specific model. All models are intended for use in swimming pool applications. The pump will function correctly only if it is properly sized to the specific application and properly installed.

WARNING

Pumps improperly sized or installed or used in applications other than for which the pump was intended can result in severe personal injury or death. These risks may include but not be limited to electric shock, fire, flooding, suction entrapment or severe injury or property damage caused by a structural failure of the pump or other system component.

WARNING

The pump can produce high levels of suction within the suction side of the plumbing system. These high levels of suction can pose a risk if a person comes within the close proximity of the suction openings. A person can be seriously injured by this high level of vacuum or may become trapped and drown. It is absolutely critical that the suction plumbing be installed in accordance with the latest national and local codes for swimming pools.

SAVE THESE INSTRUCTIONS

Before installation, be sure to read all instructions and warnings carefully.

Refer to product data plate(s) for additional operating instruction and specifications.

SAFETY WARNINGS

Inspection

Examine the equipment when received. Notify your dealer or carrier of any damage or missing parts. Verify that equipment is of size and model specified.

Important Safety Instructions

When installing and using this electrical equipment, basic safety precautions should always be followed, including the following:

1. **READ AND FOLLOW ALL INSTRUCTIONS.**
2. **WARNING** – To reduce risk of injury, do not permit children to use this product unless they are closely supervised at all times.
3. **WARNING** – (For cord & plug connected units). Risk of Electrical Shock. Connect only to a grounding type receptacle protected by a ground-fault circuit-interrupter (GFCI). Contact a qualified electrician if you cannot verify that the receptacle is protected by a GFCI.
4. **WARNING** – (For cord & plug connected units). Do not bury cord. Locate cord to minimize abuse from lawn mowers, hedge trimmers and other equipment.
5. **WARNING** – (For cord & plug connected units). To reduce the risk of electric shock, replace damaged cord immediately.
6. **WARNING** – (For cord & plug connected units). To reduce the risk of electrical shock do not use an extension cord to connect unit to electrical supply; provide a properly located outlet.
7. **CAUTION** – (For pumps with a 25 ft. (7.62m cord). This pump is for use with storable pools only. Do not use with permanently installed pools. A storable pool is constructed so that it may be readily disassembled for storage and reassembled to its original integrity. A permanently installed pool is constructed in or on the ground or in a building such that it cannot be readily disassembled for storage.
8. **CAUTION** – (For pumps with/without 3ft.(91m cord) or 6ft.(1.82m cord). This pump is for use with permanently installed pools and may also be used with hot tubs and spas if so marked. Do not use with storable pools. A permanently installed pool is constructed in or on the ground or in a building such that it cannot be readily disassembled for storage. A storable pool is constructed so that it may be readily disassembled for storage and reassembled to its original integrity.
9. **WARNING** – (For hot tub and spa pumps). Do not install within an outer enclosure or beneath the skirt of the hot tub or spa, unless so marked.
10. **SAVE THESE INSTRUCTIONS!**

Installation Location

Locate pump as close to pool/spa as possible, preferably in a dry, well ventilated area away from direct sunlight. It should be on a hard, level surface. Give consideration to:

1. Drainage – away from pump.
2. Ventilation of pump motor.
3. Access for future servicing and winterizing.
4. Protection from the elements.

Pumps without strainer bodies are designed for flooded suction (all suction fittings and suction piping below water level) and will not self-prime. Consequently, the pump must be installed at an elevation that is below water level when pool or spa is filled; however, if suction line valves are installed, the pump may be closed for priming. Keep vertical distance to a minimum if you choose to mount pump above water level.

Pumps with strainer bodies are self-priming but should be mounted as close to the water level as possible or below for ease in priming.

General Plumbing

FOR SOLVENT WELD CONNECTION

Rigid or flexible PVC pipe can be used. Pipe ends should be clean and free of any flash cause by the cutting operation. Be sure that the proper adhesive is used on the type of pipe specified.

Note: A primer will assure that adhesive joints are superior.

Caution: We recommend that you consider climatic conditions when applying adhesives. Certain atmospheric situations, such as high moisture content, make adhesive action of certain glues less effective. Check the manufacturer's instructions.

FOR THREADED CONNECTIONS

Use only Teflon tape or equivalent on threaded plumbing connections. Other pipe compounds may damage threads. We do not recommend the use of silicone or petroleum based compounds. DO NOT OVERTIGHTEN – HAND TIGHTEN PLUS ½ TURN IS SUFFICIENT.

Pump Plumbing

Suction pipe should be as large or larger than discharge pipe. Avoid using suction pipe smaller than pump connection. Keep the piping as straight and short as possible, and of suitable size. Avoid connecting an elbow directly into the pump inlet (use a length of straight pipe to allow a proper entry for the water). Arrange horizontal runs to slope upward to the pump to prevent high spots that could form air pockets. Support the pipe independently so that it places no strain on the pump. Keep as much of the suction line as possible below the water level to reduce priming time. Install valves and unions in the pump suction and return lines to facilitate servicing. Valves are recommended for throttling maintenance if the system is installed below deck level. Suction valves are essential for priming all pumps without strainer bodies installed above water level. Pumps with strainer bodies are self-priming, nevertheless, we recommend the use of check valve in the suction pipe at or below the water level if the suction lift is more than five feet or if the dry suction is more than ten feet long. Keep the valve in the suction line fully open during operation.

Electrical Data

Refer to information on motor nameplate for electrical service data. All motors should have fused disconnect switch or circuit breaker. Be sure wire size is sufficient for pump HP and distance from power source. Wiring should be done in accordance with applicable codes by a competent electrician.

We recommend the installation of a ground fault circuit interrupter for maximum safety.

Pump Start Up

Do not operate pump until it has been primed as water acts to cool and lubricate the seal. For pumps without strainer bodies and located above water, close suction line valve and fill pump with water in order to prime. For pumps with strainer bodies and located above water, prime by removing strainer cover and filling strainer body with water. Pumps located below water level will selfprime if all piping is also below water level. After pump has been

primed, energize motor and open all suction and discharge line valves. It may take some time for pump to remove air from suction lines. If no flow is observed in five minutes, stop the motor and re-prime. If the pump fails to operate, check for air leaks. Refer to Trouble Shooting section.

After about ten minutes of operation, check the return fittings for air bubbles. A continuous flow of air indicates leaks in suction line. Locate and correct any leaks immediately.

CONTROLLING THE OUTPUT

Keep the gate valve in the suction line fully open during operation. Should it be necessary to control the output, use a valve in the return line.

Caution: Do not retighten strainer Ring-Lok during operation.

Caution: Do not operate pump with closed suction or discharge valves.

Winterizing

Consult your dealer for advice on winterizing your equipment if freezing temperatures occur in your locality. His knowledge of your equipment makes him the best qualified source of information. Follow his recommendations, and if these include draining the filter system, proceed as follows:

1. If your system does not contain a filter, proceed to step 2.
 - A. For sand filters: BACKWASH for 3 to 5 minutes and set dial valve to WINTERIZE.
 - B. For cartridge filters: Clean the filter element and store in a dry place.
2. Drain system by loosening drain plugs (drain plugs will drain without completely removing the plug from unit) and/or removing pipe caps.

Water Chemistry

A proper and consistent use of chemicals is necessary to maintain clean, sanitary water, prevent a spread of germ infection and control the growth of algae which can spoil the appearance and enjoyment of your pool or spa.

Chlorine is the most commonly used chemical to provide clean, sanitary water. Either dry or liquid chlorine (calcium or sodium hypochlorite) can be used which should be added daily as it is dissipated by dirt and germs as well as by the sun and wind.

It is also important that the correct level of acidity or alkalinity of the pool water be maintained. This is the pH of your pool with pH 7.0 being neutral. Readings above 7.0 are alkaline and below are acid. A desirable range is 7.2 – 7.4.

Pump Maintenance

1. Motors are self-lubricating – no lubrication required.
2. Clean hair & lint strainer if you have a strainer body pump.
3. Visually inspect motor for blockage of air vents on motor shell. Remove any debris after breaker off.
4. Shaft seals may become worn and must be replaced if leakage is observed.

Cleaning

Switch power off. Close valves in suction and return line. Unscrew strainer Ring-Lok counterclockwise and remove the strainer cover from hair and lint strainer and lift out strainer basket. Clean and replace the basket. Take care to seat basket properly. Clean O-Ring and re-lubricate with petroleum jelly if necessary. Clean O-Ring seats on cover and strainer. Refit cover and strainer – hand tighten only – and open valves. Put pump back into operation. **Caution:** Do not re-tighten strainer during operation.

Service & Repair Parts

Refer all service to your local dealer as his knowledge of your equipment makes him the best qualified source of information. Order all repair parts through your dealer. Give the following information when ordering repair parts:

1. Unit nameplate data.
2. Description of part.

TROUBLESHOOTING

MOTOR DOES NOT START

1. Disconnect switch or circuit breaker in OFF position.
2. Fuses blown or thermal overload open. Locked motor shaft.
3. Motor windings burned out.
4. Defective starting switch inside single-phase motor
5. Disconnected or defective wiring
6. Low voltage

MOTOR DOES NOT REACH FULL SPEED

1. Low voltage
2. 2 speed model set on low speed
3. Motor windings connected for wrong voltage on dual voltage model.

MOTOR OVERHEATS (Protect trips)

1. Low voltage
2. Motor windings connected for wrong voltage on dual voltage model.
3. Inadequate ventilation

PUMP DELIVERS NO WATER

1. Pump is not primed
2. Closed valve in suction or discharge line
3. Leakage or air into suction system
4. Impeller clogged

LOW PUMP CAPACITY

1. Valve in suction or discharge line partly closed
2. Suction or discharge line partly plugged
3. Suction or discharge line too small
4. Pump running at reduced speed (see above)
5. Plugged basket in skimmer or hair and lint strainer
6. Dirty filter
7. Impeller clogged
8. Wrong rotation (3 phase only)

LOW PUMP PRESSURE

1. Pump running at reduced speed (see above)
2. Wrong rotation (3 phase only)
3. Discharge valve or inlet fittings closed too much

HIGH PUMP PRESSURE

1. Discharge valve or inlet fittings closed too much
2. Return lines too small

3. Dirty filters

NOISY PUMP AND MOTOR

1. Plugged basket in skimmer or hair in lint strainer
2. Worn motor bearings
3. Valve in suction line partly closed
4. Suction line partly plugged
5. Vacuum hose plugged or too small
6. Pump not supported properly

LEAKAGE OF WATER AT SHAFT 1.

Shaft seal requires replacement

AIR BUBBLES AT INLET FITTINGS

1. Leakage air into suction line at connections or valve stem
2. Cover gasket of hair and lint strainer needs cleaning
3. Restriction in suction line
4. Low water level in pool

NOTE: If the recommendations in the Trouble Shooting portion of this manual do not solve your particular problem(s), please contact your local dealer for service.

TECHNICAL DATA

Model	HP	RPM	Volte / HZ	Amps	Remark
75405	1.0HP	3450	230/115V 60HZ	11.8/5.7 A	Single- speed

PARTS INFORMATION

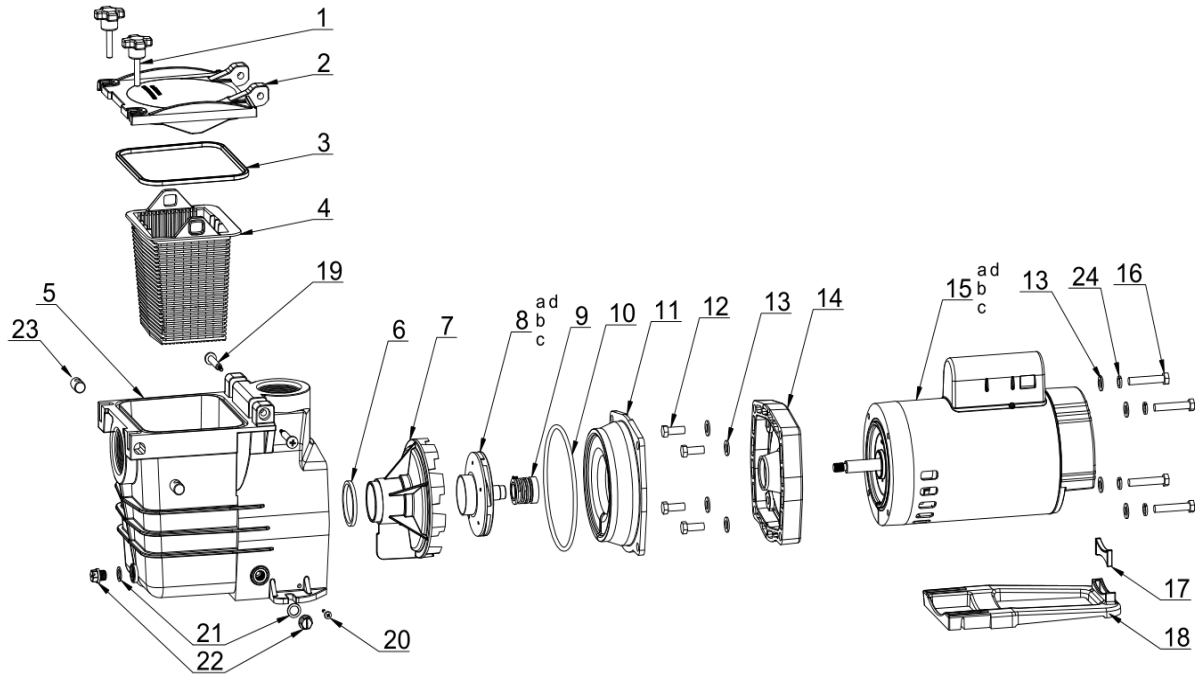

Ref. No.	Part No.	Description	QTY
1	648910606080	Handle screw	2
2	648915102089	Cover	1
3	65432053080	Gasket	1
4	648910402001	Basket	1
5	648915104080	2" Pump housing	1
6	65432040080	o-ring	1
7	647258001080	Diffuser	2
8a	89106101	Impeller for 72840NC	1
8b	89106201	Impeller for 72841 NC	1
8c	647278172000	Impeller for 72842 NC	1
8d	647258072000	Impeller for 72843 NC	1
9	65028026000	Seal assembly	1
10	65431121080	o-ring	1
11	647258002080	Pump cover	1
12	65225007000	Screw 3/8-16UNC*25.4mm	4
13	65244015000	Gasket M10	8
14	648910602	Over cover	1
15a	65023232000	1.0HP motor for 72840 NC	1
15b	65023233000		1
15c	65023229000		1
15d	65023239000		1
16	65225008000	Screw 3/8-16UNC*50.8mm	4
17	648912301080	Supporting foot	1
18	648910608080	Mounting foot	1
19	65212058000	Screw	2
20	65212013000	Screw ST4.8*25	2
21	65432002080	Gasket	1
22	648860105080	Drain plug	2
23	648910607080	Pin	2
24	65244032000	Spring washer	4

DISCLAIMER

PLEASE READ THE FOLLOWING CAREFULLY

THE MANUFACTURER AND/OR DISTRIBUTOR HAS PROVIDED THE PARTS LIST AND ASSEMBLY DIAGRAM IN THIS MANUAL AS A REFERENCE TOOL ONLY. NEITHER THE MANUFACTURER OR DISTRIBUTOR MAKES ANY REPRESENTATION OR WARRANTY OF ANY KIND TO THE BUYER THAT HE OR SHE IS QUALIFIED TO MAKE ANY REPAIRS TO THE PRODUCT, OR THAT HE OR SHE IS QUALIFIED TO REPLACE ANY PARTS OF THE PRODUCT. IN FACT, THE MANUFACTURER AND/OR DISTRIBUTOR EXPRESSLY STATES THAT ALL REPAIRS AND PARTS REPLACEMENTS SHOULD BE UNDERTAKEN BY CERTIFIED AND LICENSED TECHNICIANS, AND NOT BY THE BUYER. THE BUYER ASSUMES ALL RISK AND LIABILITY ARISING OUT OF HIS OR HER REPAIRS TO THE ORIGINAL PRODUCT OR REPLACEMENT PARTS THERETO, OR ARISING OUT OF HIS OR HER INSTALLATION OF REPLACEMENT PARTS THERETO.

Record Product's Serial Number Here: _____

Note: If product has no serial number, record month and year of purchase instead.

Note: Some parts are listed and shown for illustration purposes only and are not available individually as replacement parts.

The material in this manual is for informational purposes only. The product(s) it describes are subject to change without prior notice, due to the manufacturer's continuous development program. XtremePowerUS makes no representations or warranties with respect to this manual or with respect to the products described herein. XtremePowerUS shall not be liable for any damages, losses, costs or expenses, direct, indirect or incidental, consequential or special, arising out of, or related to the use of this material or the products described herein.

Questions, issues or missing parts?

Before returning to your retailer, our customer service team is here to help.



Call Us: 909.628.0880

Email Us: customer@xtremepowerusa.com

Hours of Operation: 9am - 3pm PST Monday - Friday

MADE IN CHINA