

the LifeStyle
Barton
Home Office Patio

Outdoor Wicker Float Towel Valet

ITEM # 90139

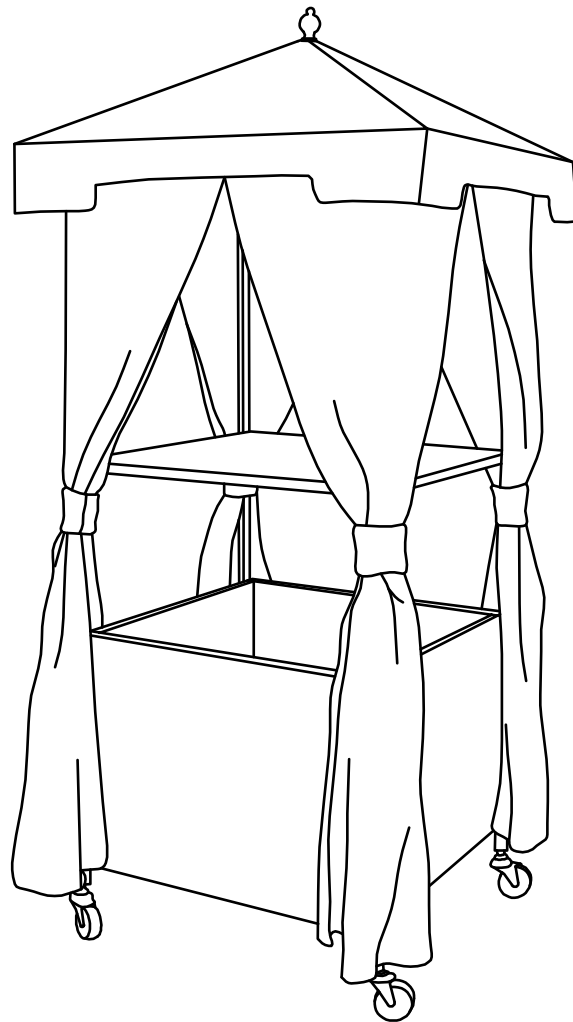









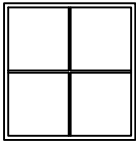
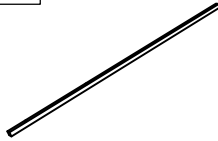
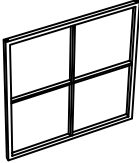
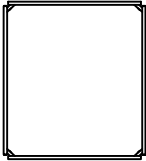
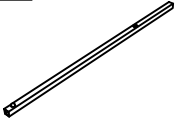

OWNER'S MANUAL AND SAFETY INSTRUCTIONS



SAVE THIS MANUAL. KEEP THIS MANUAL FOR SAFETY WARNINGS, PRECAUTIONS, ASSEMBLY, OPERATION, INSPECTION, MAINTENANCE AND CLEANING PROCEDURES. WRITE THE PRODUCT'S SERIAL NUMBER ON THE BACK OF THE MANUAL, OR THE MONTH AND YEAR OF PURCHASE IF PRODUCT HAS NO SERIAL NUMBER

FOR QUESTIONS, PLEASE CALL CUSTOMER SERVICE: 909.628.0880

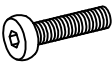

PART LIST

A 	B 	C 	D 	E 
Long Side Panel 2 PCS	Short Side Panel 2 PCS	Bottom Panel 1 PC	Long Post 4 PCS	Shelf 1 PC
F 	G 	H 	I 	J 
Top Frame 1 PC	Rib 4 PCS	Hub 1 PC	Connector 4 PCS	Finial 1 PC
K 	L 	M 	N 	
Locking Caster 2 PCS	Swivel Caster 2 PCS	Top Cover 1 PC	Fabric Curtain 1 PC	

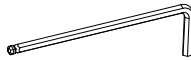
HARDWARE LIST

#1 	#2 	#3 	#4 
M6*15mm	M6*38mm	M6mm	M6mm
Short Bolt 8 PCS	Long Bolt 28 PCS	Washer 36 PCS	Allen Key 1 PC

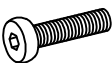
EXTRA HARDWARE LIST

#1 	#2 	#3 
M6*15mm	M6*38mm	M6mm
Short Bolt 2 PCS	Long Bolt 3 PCS	Washer 3 PCS

Step 1. Attach long side panels (part A) to long posts (part D) using the long bolts (part #2), washers (part #3) and allen key (part #4). Attach swivel casters (part L) and locking casters (part K) to long posts (part D).

NOTE: Please do not fully tighten bolts until unit is fully assembled.

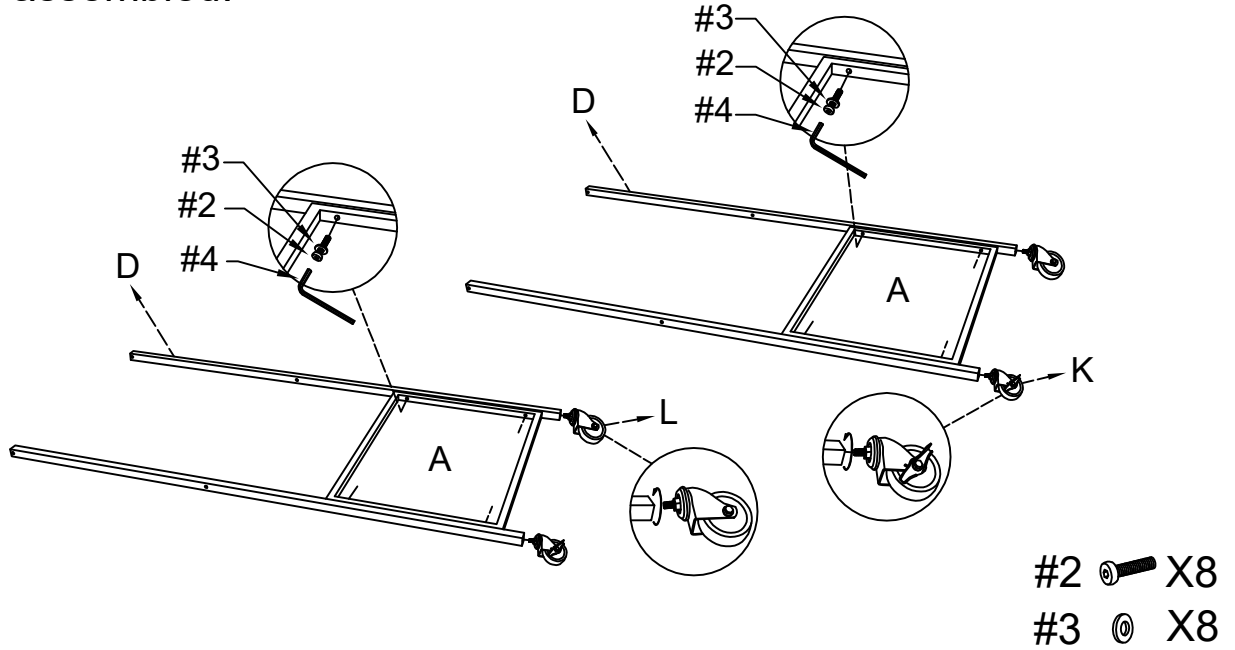

Step 2. Attach short side panels (part B) to long side panels (part A) of assembled parts (part A,D,L&K) using long bolts (part #2), washers (part #3) and allen key (part #4).

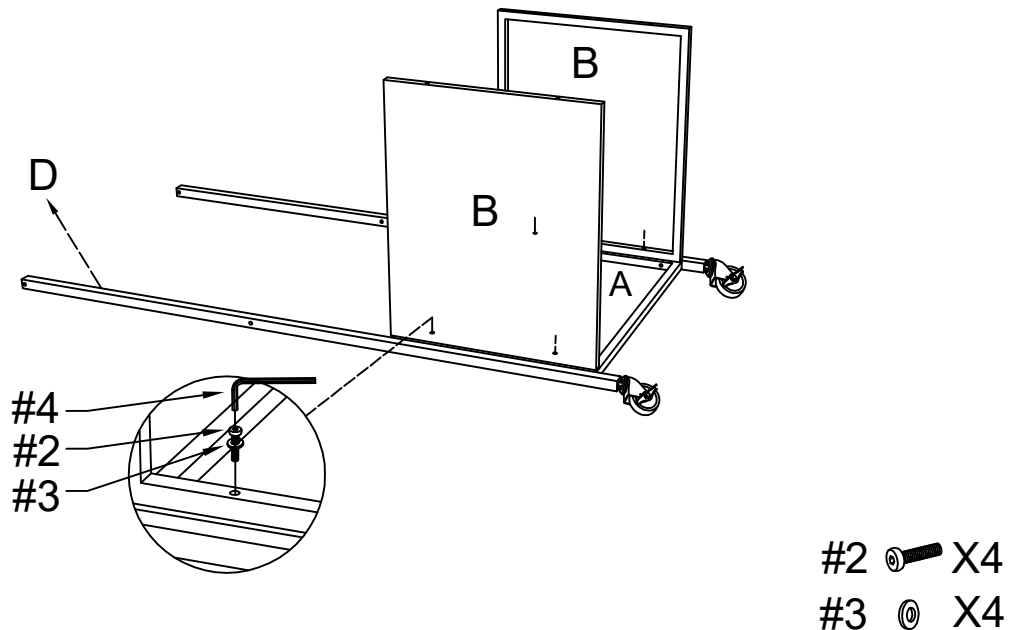

Step 3. Attach assembled parts (part A,D,L&K) to short side panels (part B) of assembled parts (part A,B,D,L&K) using long bolts (part #2), washers (part #3) and allen key (part #4).

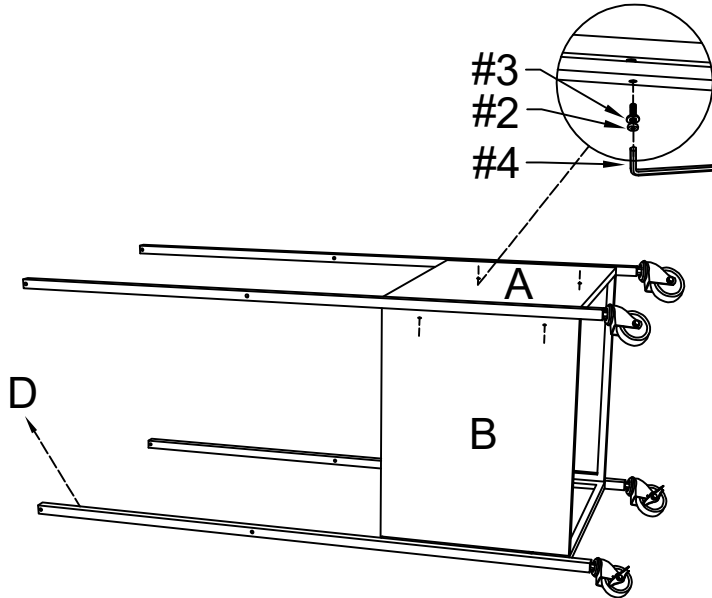

#2  X4

#3  X4

Step 4. Attach bottom panel (part C) to short side panels (part B) of assembled parts (part A,B,D,L&K) using long bolts (part #2), washers (part #3) and allen key (part #4).

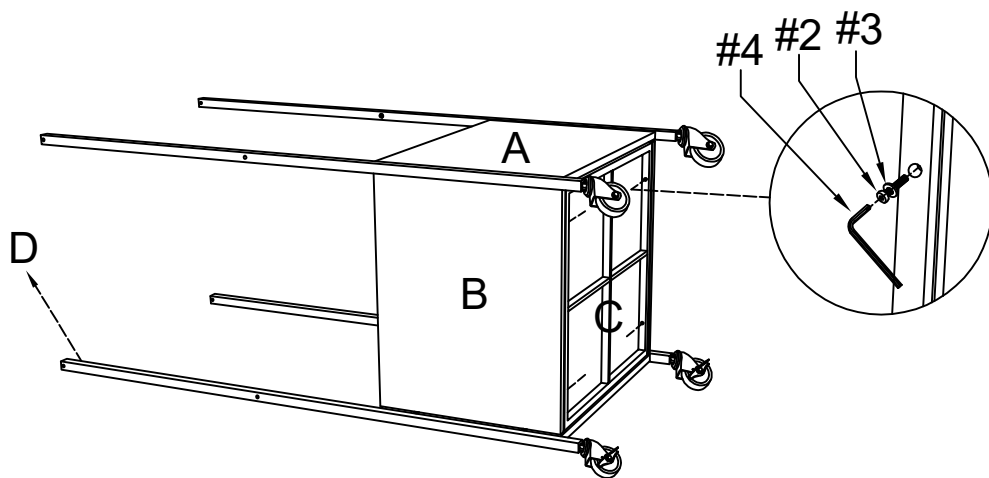

#2  X4

#3  X4

Step 5. Attach shelf (part E) to long posts (part D) of assembled parts (part A,B,C,D,L&K) using long bolts (part #2), washers (part #3) and allen key (part #4).

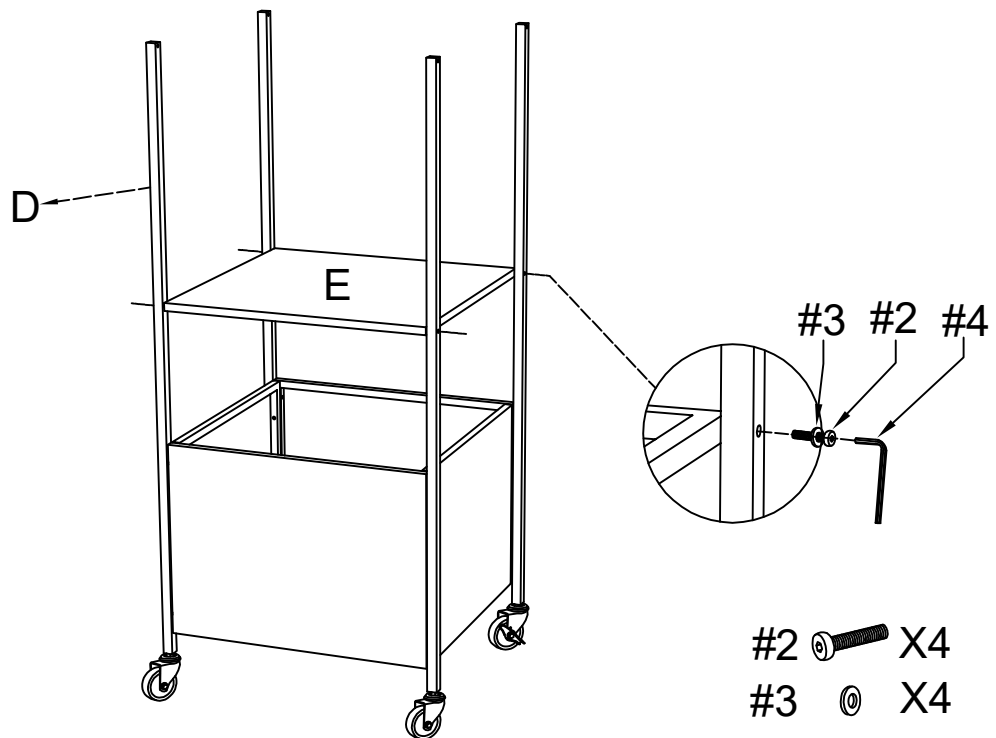

Step 6. Attach top frame (part F) to long posts (part D) of assembled parts (part A,B,C,D,E,L&K) using long bolts (part #2), washers (part #3) and allen key (part #4).

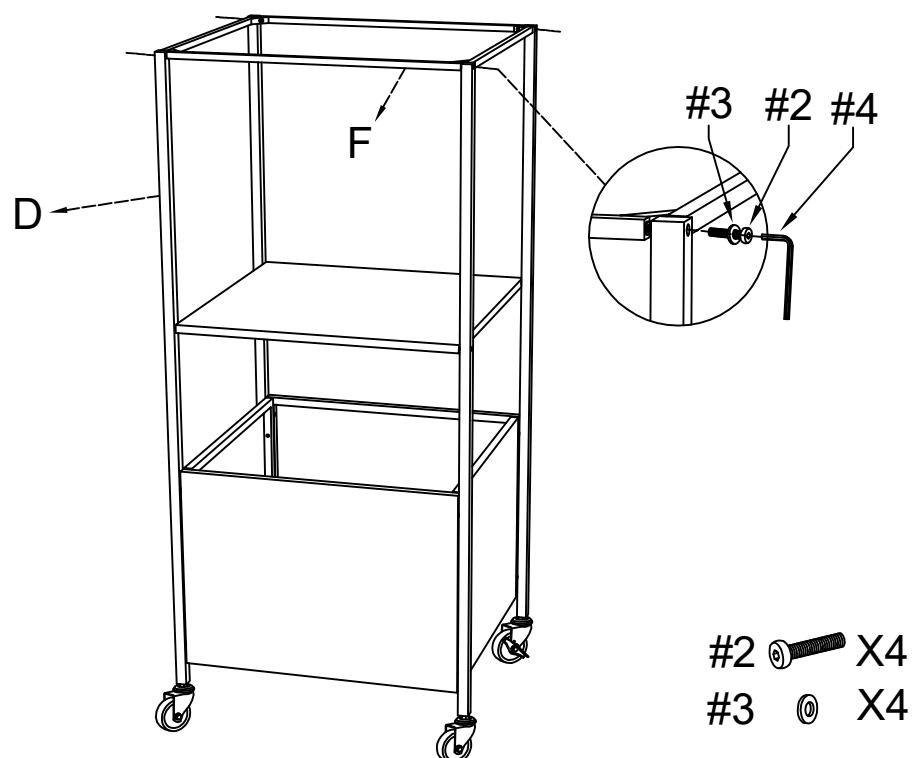

Step 7. Attach connectors (part I) to top frame (part F) of assembled parts (part A,B,C,D,E,F,L&K) using short bolts (part #1), washers (part #3) and allen key (part #4).

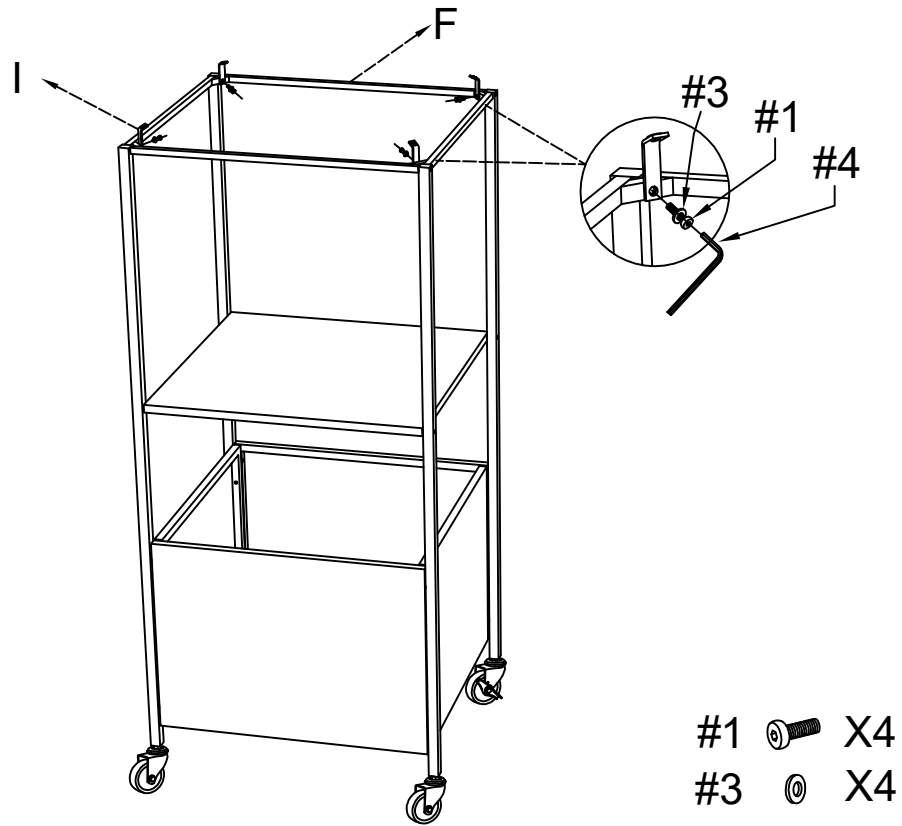

Step 8. Fully insert ribs (part G) into the hub (part H) until spring clips click into place.

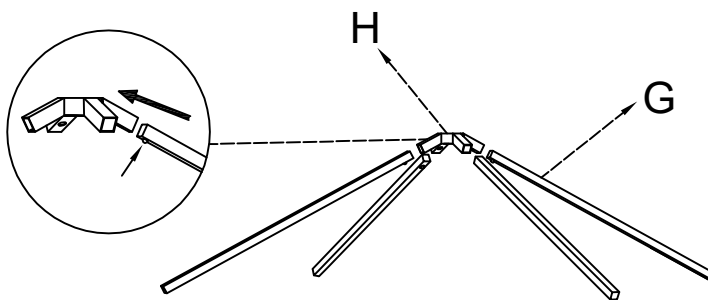

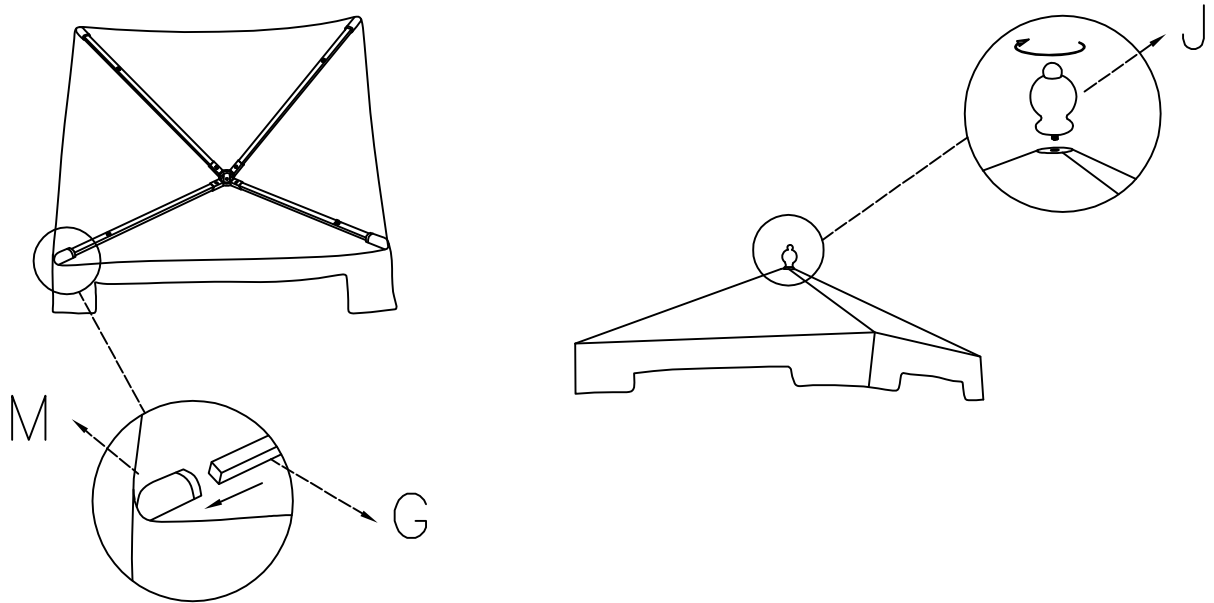

Step 9. Unfold top top cover (part M) and attach to assembled parts (part G&H) as shown below. Attach finial to hub (part H) of assembled parts (part G,H&M) to secure together.

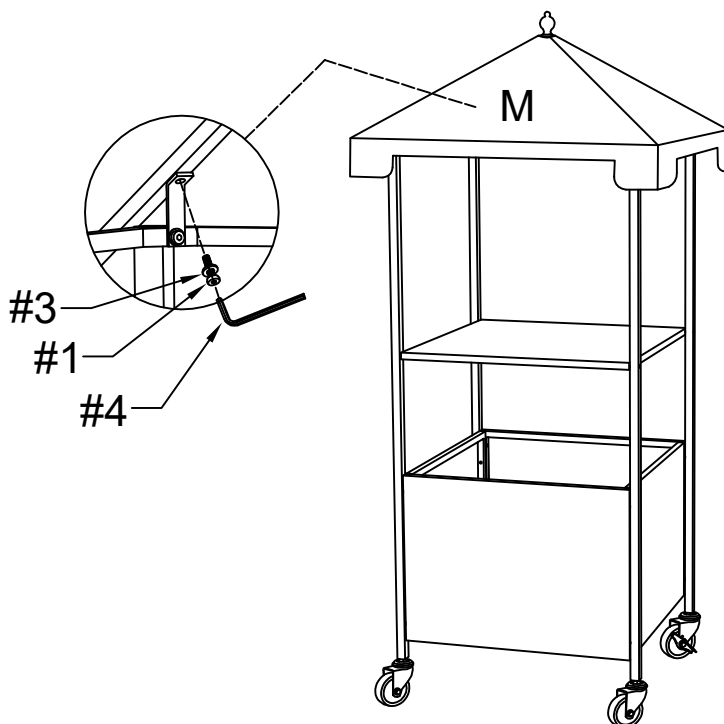

Step 10. Attach assembled parts (part G,H,J&M) to connectors (part I) of assembled parts (part A,B,C,D,E,F,I,L&K) using short bolts (part #1), washers (part #3) and allen key (part #4).

NOTE: Please fully tighten all bolts at this time.



#1  X4
 #3  X4

Step 11. Secure fabric curtains (part N) to top frame (part F) of the completed unit with Velcro[®] straps as shown.

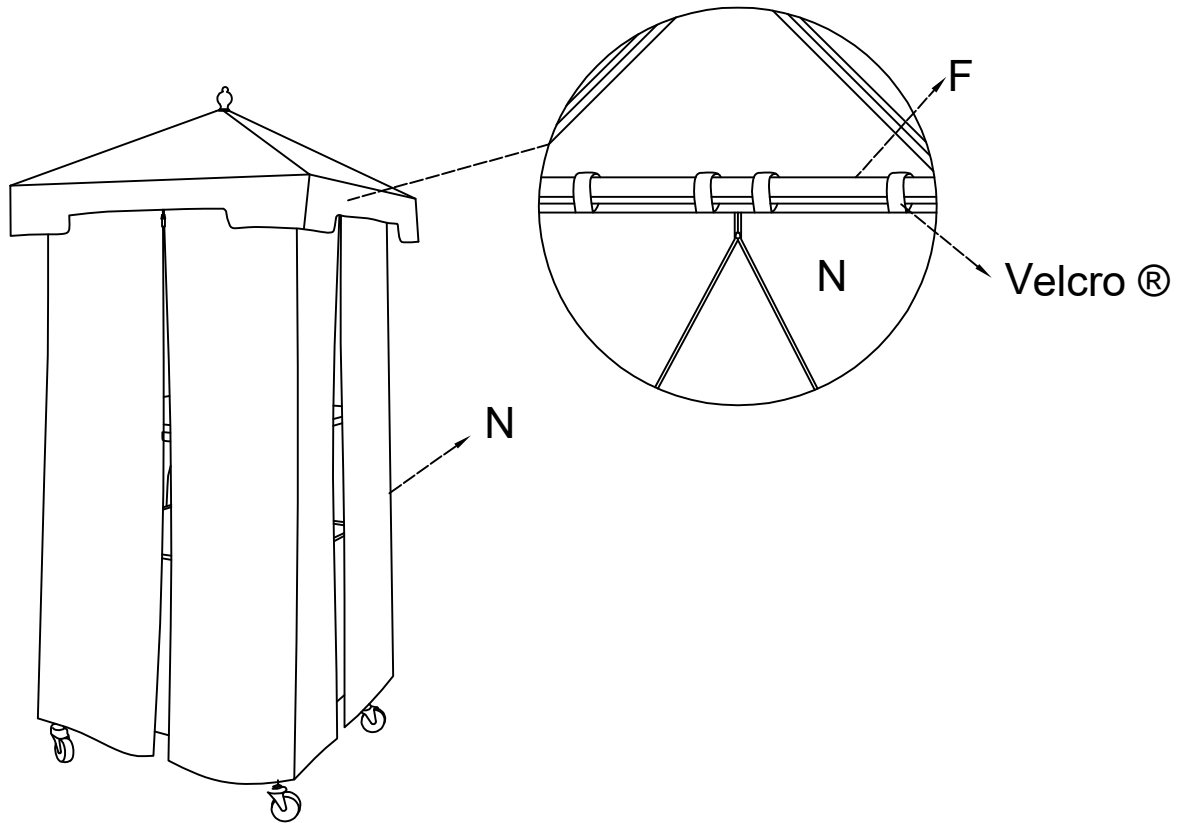

Step 12. NOTE: Curtains (part N) can be held open by using the Velcro[®] straps to secure them to long posts (part D) of the completed unit as shown below.

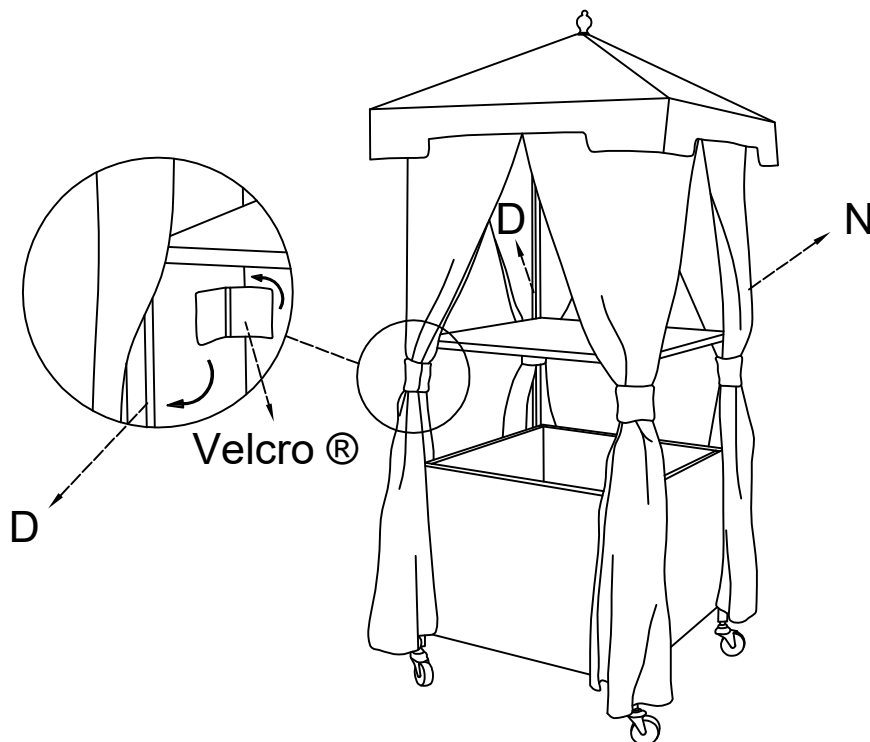

DISCLAIMER

PLEASE READ THE FOLLOWING CAREFULLY

THE MANUFACTURER AND/OR DISTRIBUTOR HAS PROVIDED THE PARTS LIST AND ASSEMBLY DIAGRAM IN THIS MANUAL AS A REFERENCE TOOL ONLY. NEITHER THE MANUFACTURER OR DISTRIBUTOR MAKES ANY REPRESENTATION OR WARRANTY OF ANY KIND TO THE BUYER THAT HE OR SHE IS QUALIFIED TO MAKE ANY REPAIRS TO THE PRODUCT, OR THAT HE OR SHE IS QUALIFIED TO REPLACE ANY PARTS OF THE PRODUCT. IN FACT, THE MANUFACTURER AND/OR DISTRIBUTOR EXPRESSLY STATES THAT ALL REPAIRS AND PARTS REPLACEMENTS SHOULD BE UNDERTAKEN BY CERTIFIED AND LICENSED TECHNICIANS, AND NOT BY THE BUYER. THE BUYER ASSUMES ALL RISK AND LIABILITY ARISING OUT OF HIS OR HER REPAIRS TO THE ORIGINAL PRODUCT OR REPLACEMENT PARTS THERETO, OR ARISING OUT OF HIS OR HER INSTALLATION OF REPLACEMENT PARTS THERETO.

Record Product's Serial Number Here: _____

Note: If product has no serial number, record month and year of purchase instead.

Note: Some parts are listed and shown for illustration purposes only and are not available individually as replacement parts.

The material in this manual is for informational purposes only. The product(s) it describes are subject to change without prior notice, due to the manufacturer's continuous development program. Barton makes no representations or warranties with respect to this manual or with respect to the products described herein. Barton shall not be liable for any damages, losses, costs or expenses, direct, indirect or incidental, consequential or special, arising out of, or related to the use of this material or the products described herein.

Questions, issues or missing parts?

Before returning to your retailer, our customer service team is here to help.



Call Us: 909.628.0880

Email Us: customer@bartonliving.com

Hours of Operation: 9am - 3pm PST Monday - Friday

MADE IN CHINA