

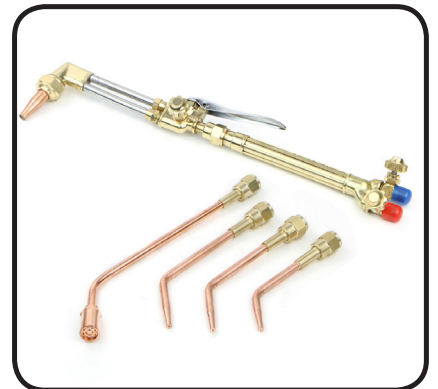

WELDING CUTTING TORCH KIT VICTOR TYPE

ITEM: 55147



OWNER'S MANUAL AND SAFETY INSTRUCTIONS

SAVE THIS MANUAL: KEEP THIS MANUAL FOR SAFETY WARNINGS, PRECAUTIONS, ASSEMBLY, OPERATING, INSPECTION, MAINTENANCE AND CLEANING PROCEDURES. WRITE THE PRODUCT'S SERIAL NUMBER ON THE BACK OF THE MANUAL NEAR THE ASSEMBLY DIAGRAM (OR MONTH AND YEAR OF PURCHASE IF PRODUCT HAS NO NUMBER).

FOR QUESTIONS PLEASE CALL OUR CUSTOMER SUPPORT: (909) 628 4900 MON-FRI 9AM TO 3PM PST



GENERAL SAFETY WARNINGS

Read all safety warnings and instructions. Failure to follow the warnings and instructions may result in electric shock, fire and/or serious injury. Save all warnings and instructions for future reference.

SAFETY

The warnings, precautions, and instructions discussed in this instruction manual cannot cover all possible conditions and situations that may occur. It must be understood by the operator that common sense and caution are factors which cannot be built into this product, but must be supplied by the operator. Read carefully and understand all ASSEMBLY AND OPERATION INSTRUCTIONS before operating. Failure to follow the safety rules and other basic safety precautions may result in serious personal injury.

- **Read and understand all instructions.** Failure to follow all instructions may result in serious injury or property damage.
- **DO NOT** allow persons to operate or assemble the product until they have read this manual and have developed a thorough understanding of how it works.
- **DO NOT modify this product in any way.** Unauthorized modification may impair the function and/or safety and could affect the life of the product. There are specific applications for which the product was designed.
- **Inspect the work area before each use.** Keep work area clean, dry, free of clutter, and well-lit. Cluttered, wet, or dark work areas can result in injury. Using the product in confined work areas may put you dangerously close to cutting tools and rotating parts.
- **DO NOT use the product where there is a risk of causing a fire or an explosion;** e.g. in the presence of flammable liquids, gases, or dust. The product can create sparks, which may ignite the flammable liquids, gases, or dust.
- **DO NOT allow the product to come into contact with an electrical source.** The tool is not insulated and contact will cause electrical shock.
- **Keep children and bystanders away from the work area while operating the tool. DO NOT** allow children to handle the product.
- **Be aware of all power lines, electrical circuits, water pipes, and other mechanical hazards in your work area.** Some of these hazards may be hidden from your view and may cause personal injury and/or property damage if contacted.
- Stay alert, watch what you are doing, and use common sense when operating the tool. **DO NOT** use the tool while you are tired or under the influence of drugs, alcohol, or medication.
- **Dress properly. DO NOT** wear loose clothing, dangling objects, or jewelry. Keep your hair, clothing and gloves away from moving parts. Loose clothes, jewelry, or long hair can be caught in moving parts.
- **DO NOT overreach.** Keep proper footing and balance at all times.
- **Wear the proper personal protective equipment when necessary.** Use ANSI Z87.1 compliant safety goggles (not safety glasses) with side shields, or when needed, a face shield. Use a dust mask in dusty work conditions.

IMPORTANT SAFETY INFORMATION

- Remove keys or wrenches before connecting the tool to an air supply, power supply, or turning on the tool. A wrench or key that is left attached to a rotating part of the tool may cause personal injury.
- **Check for damaged parts before each use.** Carefully check that the product will operate properly and perform its intended function. Replace damaged or worn parts immediately. Never operate the product with a damaged part.
- **DO NOT use a product with a malfunctioning switch.** Any power tool that cannot be controlled with the power switch is dangerous and must be repaired by an authorized service representative before using.
- **Disconnect the power/air supply from the product and place the switch in the locked or off position before making any adjustments,** changing accessories, or storing the tool. Such preventive safety measures reduce the risk of starting the tool accidentally.
- When possible, move the work to a location well away from combustible materials. If relocation is NOT possible, protect the combustibles with a cover made of fire resistant material. Remove or make safe all combustible materials for a radius of 35 feet (10 meters) around the work area.
- Enclose the work area with portable fire resistant screens. Use a fire resistant material to block all openings and protect combustible walls, ceilings, floors, etc.
- If working near/on a metal wall, ceiling, floor, etc., prevent ignition of combustibles on the other side by moving the combustibles to a safe location. If relocation of combustibles is NOT possible, designate someone to act as a fire watch equipped with a fire extinguisher during the welding or cutting process and for at least one half hour after the welding or cutting project is completed.
- **DO NOT** place the Torch on any material other than bare concrete until it has cooled completely.
- **DO NOT** weld or cut any material that has a combustible coating or a combustible internal structure, such as drums or tanks, without an approved method for eliminating the hazard.
- **DO NOT** dispose of hot slag in containers holding combustible materials.
- Keep a fully charged fire extinguisher close by and know the proper way to use it.
- After welding or cutting make a thorough check for evidence of fire and be aware the easily visible flame or smoke may not be present for some time after a fire has started.
- Clean and purge containers before applying heat. **DO NOT** apply heat to a container that has held an unknown substance or a combustible material whose contents, when heated, can produce flammable or explosive vapors. Vent closed containers, including castings, before preheating, cutting, or welding.
- **INHALATION HAZARD:** Welding and Cutting Produce TOXIC FUMES. Exposure to welding or cutting exhaust fumes can increase the risk of developing certain cancers, such as cancer of the larynx and lung cancer. Also, some diseases that may be linked to exposure to welding or cutting exhaust fumes are: • Early onset of Parkinson's Disease • Heart disease • Ulcers • Damage to the reproductive organs • Inflammation of the small intestine or stomach • Kidney damage • Respiratory diseases such as emphysema, bronchitis, or pneumonia Use natural or forced air ventilation and wear a respirator approved by NIOSH to protect against the fumes produced to reduce the risk of developing the above illnesses.
- **WARNING:** This product, when used for welding, plasma cutting, soldering, or similar applications, produces chemicals known to the State of California to cause cancer and birth defects or other reproductive harm. (California Health & Safety Code § 25249.5, et seq.)
- **WARNING:** The brass components of this product contain lead, a chemical known to the State of California to cause cancer and birth defects or other reproductive harm. (California Health & Safety Code § 25249.5, et seq.)

IMPORTANT SAFETY INFORMATION

- Make sure you are prepared to begin work before opening gas supply.
- **ALWAYS** use reverse-flow on the torch and regulator. This greatly reduces the possibility of mixing gases in the regulator or hose.
- Use with oxygen and acetylene only. **DO NOT** modify this torch or use it for a purpose for which it is not intended.
- Set Acetylene Regulator no greater than 15 PSI. Acetylene is unstable and can explode if over-pressurized.
- **DO NOT** use oil, grease or thread seal tape on any connector.
- Use clamps (not included) or other practical ways to secure and support the work piece to a stable platform. Holding the work by hand or against your body is unstable and may lead to loss of control, fire and/or personal injury.
- Use only accessories that are recommended by the manufacturer for your model Torch. Accessories that may be suitable for one Torch may become hazardous when used on another Torch. Only use proper gas hoses.
- Proper cylinder care. Secure cylinders to a cart, wall or post to prevent them from falling. All cylinders should be used and stored in an upright position. Never drop or strike a cylinder. Cylinder caps should be used when moving or storing cylinders. Empty cylinders should be kept in specified areas and marked "empty"
- **NEVER** use oil or grease on any inlet connector, outlet connector or cylinder valves. Keep regulators free of gas and oil.
- There must be TWO O-rings on the cone end. The absence of either O-ring can lead to flashback within the torch handle or cutting attachment.
- **DO NOT** store cylinders in temperatures 120° F or higher.
- **KEEP WRENCH ON ACETYLENE CYLINDER'S VALVE** whenever cylinder is in use to allow quick shut off in case of emergency.
- **DO NOT USE FLAME TO DETECT LEAKS.**
- **INSPECT BEFORE EVERY USE.** Look for the following, and do not use kit if any damage is noted:
 - A.** Inspect the tapered seating surfaces on the Nozzles and the Tip Nut. Have a qualified technician resurface the seat area if it has dents, burrs, or is burned. A poor seating surface may result in backfire or flashback.
 - B.** Examine all hoses for cuts, cracks, burns, worn areas, or other damage. **DO NOT** use if damaged.
 - C.** Check for loose connections using soapy water solution. Tighten or repair any leaks found.
 - D. DO NOT** use the Torch Kit if either gas does not turn off completely when the Oxygen Torch Valve and Acetylene Torch Valve are closed. Leakage of gas from the tip is a substantial safety risk. If gas cannot be turned off at the Torch Handle, it is dangerous and must be replaced.
 - E.** Inspect for any other defects or damage. Do not use any damaged parts. Tag damaged parts "Do not use" until repaired.
- **Backfire and Flashback:** When the flame goes out with a loud "pop" it is called a backfire. Backfire can be caused by **A.** Operating the torch at low pressures required for the toll tips used. **B.** Touching the tip against the work piece. **C.** Overheating the tip or abstraction in the tip. If backfire occur, shut off the torch handle valves, oxygen first, and after remedying the cause, relight the torch. If flashback occurs, close the torch handle valves immediately. Flashback generally indicates a problem that needs repaired. A clogged tip, improper functioning in the valves or incorrect oxygen pressure. Make sure to find and fix the cause before lighting the torch.

ASSEMBLY AND OPERATION

PRODUCT SPECIFICATIONS

ITEM	DESCRIPTION
Torch Handle, Oxygen Regulator and Acetylene Regulator	All brass construction with polished finished
Cutting Nozzle	Brass and steel, chrom eplated oxygen lever
Welding Nozzle and Heating Nozzle	Brass base with a copper tip
Welding Hose Size	2x 12 Ft. long x 1/4" rubber and brass fittings
Tip Cleaner	Steel files
Flint Lighter	Chrome plated steel with flint tip

ASSEMBLY AND OPERATING PROCEDURES

NOTE: The following instructions are for acetylene gas use only. **DO NOT** use other fuel gases.

1. While standing on one side, “crack” each cylinder valve. “Cracking” is to quickly open and close the valve, allowing gas to escape and clearing the valve of any foreign material. If any oil or grease is found do not use the cylinder and contact the supplier immediately.

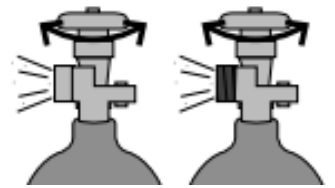

2. Attach the **GREEN** oxygen regulator (Parts A1-A20E) to the oxygen cylinder. Then, attach the **RED** acetylene regulator (parts 1-19) to the acetylene cylinder. Make sure they are tightened in the correct directions (normally clockwise for oxygen and counter-clockwise for acetylene) **DO NOT USE THREAD SEALING TAPE.**

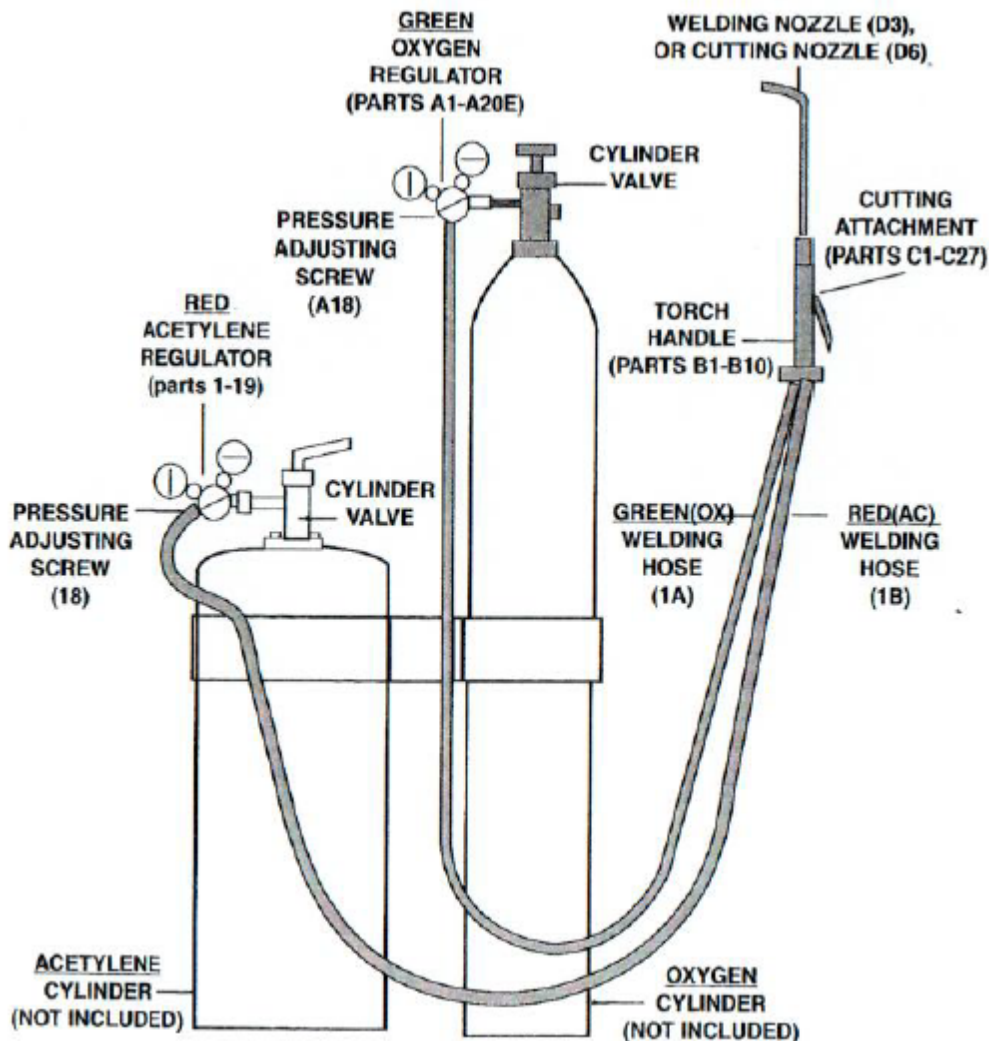

ASSEMBLY AND OPERATION

3. IMPORTANT: The pressure adjusting screw (18) on the acetylene regulator and the pressure adjusting screw (A18) on the oxygen regulator should be turned counter-clockwise to relieve pressure on the regulator diaphragms before opening the cylinder valves. If this is not done, pressure from the cylinders may damage the diaphragms and render the regulators inoperable.

4. Connect the **GREEN** and **RED** welding hoses (1A or 1B) to the proper connections on the torch handle (parts B1-B10)

5. Connect the cutting attachment (C1-C27) to the torch handle (B1-B10) Always check the cone end (C23) and coupling nut (C22) for damage or oil. If either are found, discontinue use and contact your gas supplier.

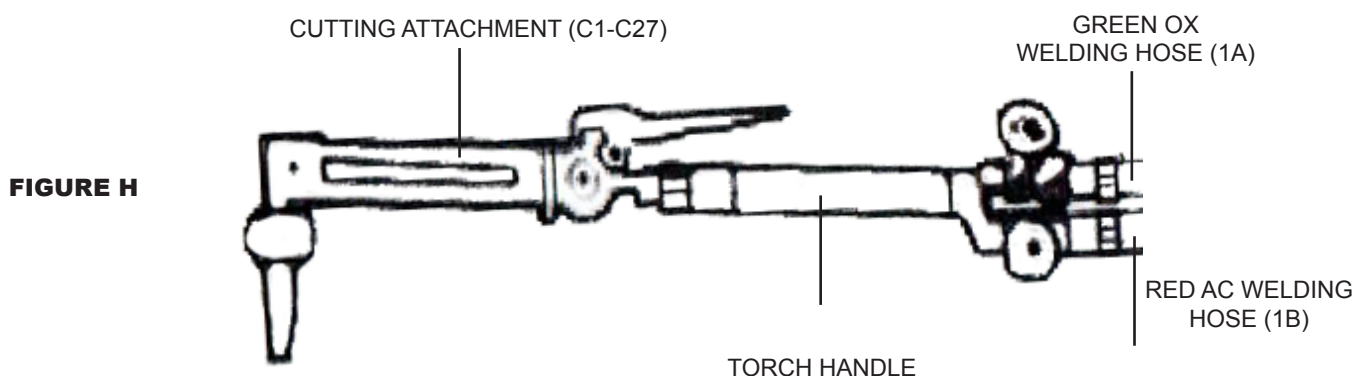
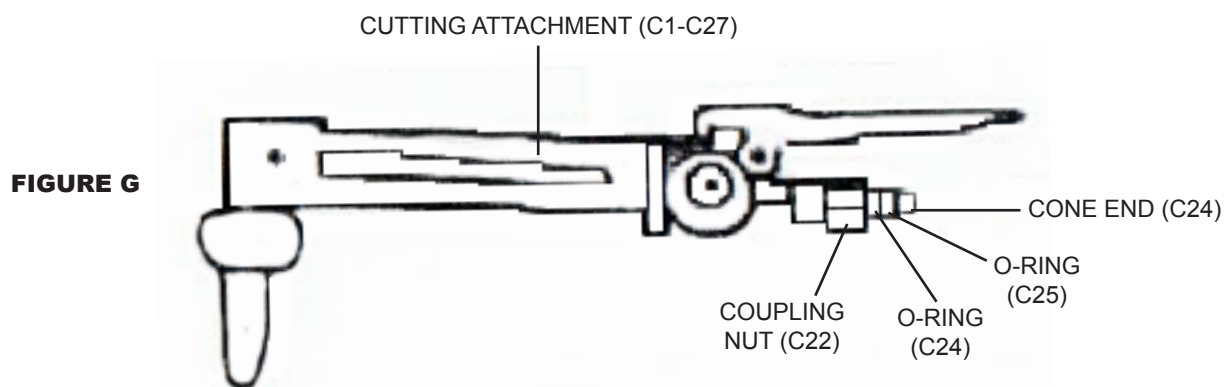
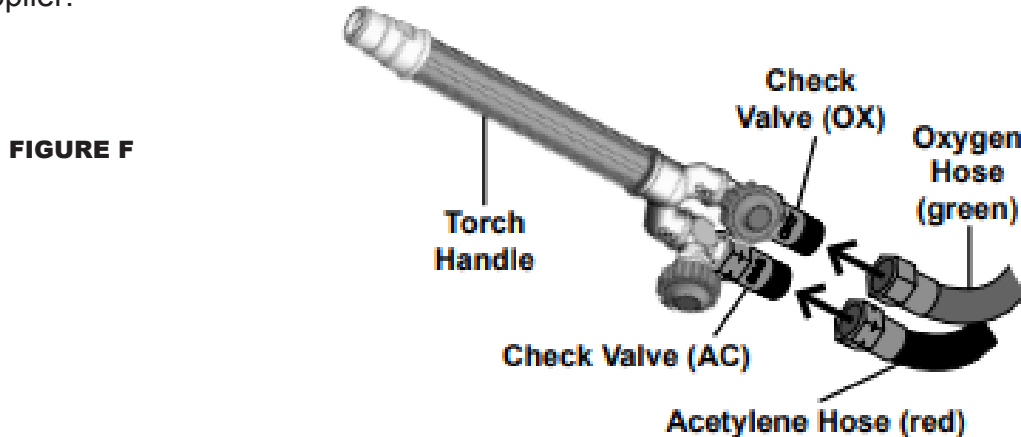

6. Check connections for leaks. Adjust the acetylene regulator (parts 1-19) and oxygen regulator (parts A1-A20E) to their normal operating pressure. Use an approved leak detection solution to check for leaks at the welding hoses (A1 and 1B) and cylinder valve connections. If leaks are found, tighten nuts more securely.

CHECKING FOR LEAKS

1. After everything is connected, close both Torch Handle Valves, turning clockwise. Close Regulators, turning knobs counter-clockwise until loose.

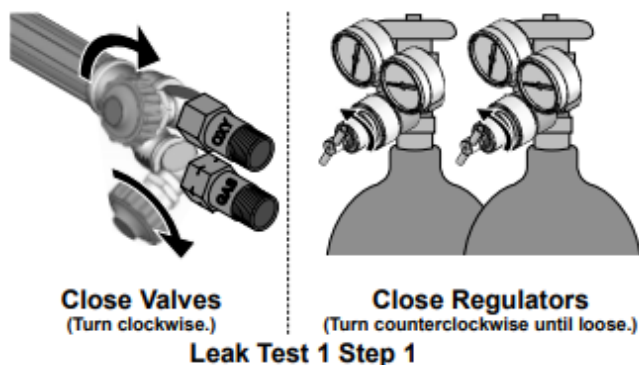

2. Open the cylinder valves turning counter-clockwise only until the gas starts flowing. **WARNING!** Only open Acetylene Cylinder Valve 1/4 to 1/2 turn.

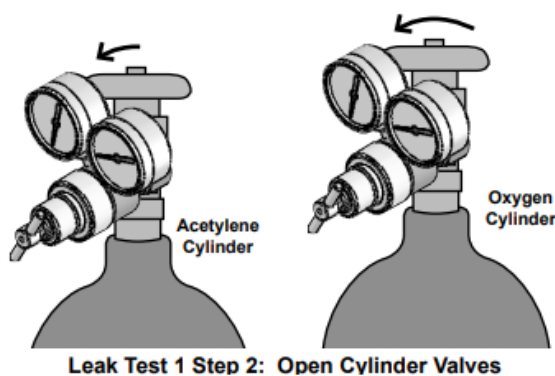

3. Open the Oxygen cylinder valve completely, turning it counter-clockwise.

4. Adjust the Oxygen Regulator to deliver 20 PSI. Adjust the Acetylene Regulator to deliver 10 PSI. **DO NOT EXCEED 15 PSI ACETYLENE PRESSURE.**

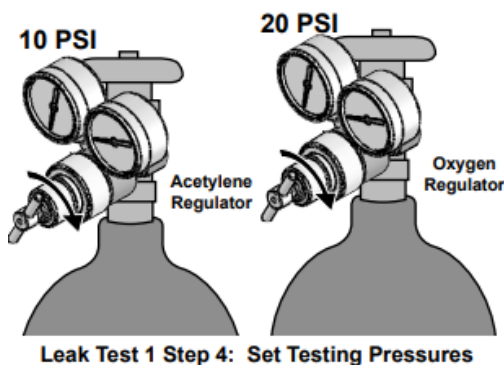

5. Check all connections for leaks using soapy water: • If leaks are found, tighten connections. • If a leak persists, discontinue use and call gas supplier. • If no leaks are found with this test, move on to the Gauge Monitoring test.



DANGER! To prevent serious injury and/or death, **DO NOT** tighten or adjust any connection between the cylinder and cylinder valve, or force the cylinder valve. If the cylinder valve is leaking, move the cylinder outside and notify your gas supplier immediately.

CHARTS

WARNING

NEVER set the Acetylene Regulator (Parts 1-19) to a delivery pressure above 15 PSI. See figures I, J and K

WELDING TIP CHART

FIGURE I

METAL THICKNESS	TIP SIZE	OXYGEN PRESSURE		ACETYLENE PRESSURE	
		MIN	MAX		
1/64" - 3/64"	00	3	5	3	5
1/32" - 5/64"	0*	3	5	3	5
3/64" - 3/32"	1	3	5	3	5
1/16" - 1/8"	2	3	5	3	5
1/8" - 3/16"	3	4	7	3	6
3/16" - 1/4"	4	5	10	4	7
1/4" - 1/2"	5	6	12	5	8

OXYACETYLENE MULTI-FLAME HEATING CHART

FIGURE J

TIP SIZE	ACETYLENE PRESSURE	OXYGEN PRESSURE	ACETYLENE CUBIC FT PER HOUR		OXYGEN CUBIC FT PER HOUR	
	RANGE	RANGE	MIN	MAX	MIN	MAX
6	4 TO 6	8 TO 11	14	40	15	44
8	8 TO 12	10 TO 18	30	80	33	88

OXYACETYLENE CUTTING NOZZLE CHART

FIGURE K

METAL THICKNESS	NOZZLE SIZE	OXYGEN PRESSURE RANGE	OXYGEN CUBIC FT PER HOUR		ACETYLENE CUBIC FT PER HOUR	
			MIN	MAX	MIN	MAX
1/2"	0	8 TO 11	30	35	3	5
3/4"	1**	10 TO 18	30	35	3	5

9. To determine the proper acetylene regulator parts (parts 1-19) pressure and oxygen regulator (parts A1-A20E) pressure for neutral flame adjusting. Refer to Figures I and K

10. Depending on use, attach either the cutting nozzle (D6) or welding nozzle (D3) to the cutting attachment (parts C1-C27) See figure L

11. Open the oxygen control valve (B8 with Ox label B9) on the torch handle. Open the pre-heat oxygen valve (C26) on the cutting attachment. Adjust the oxygen regulator parts (A1 - A20) to the desired working pressure. Then close the oxygen control valve on the torch handle. See figure L

OPERATION

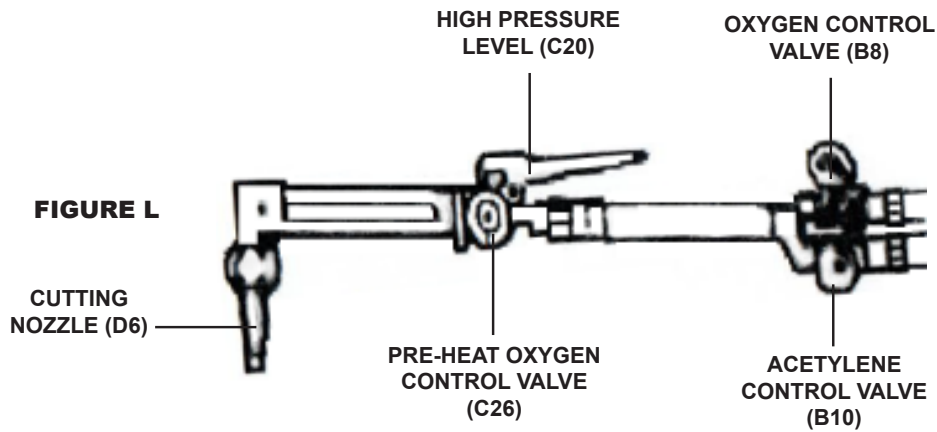

12. Open the acetylene control valve (B8 with AC label (B10) on the torch handle. Adjust the acetylene regulator (parts 1-19) to the desired working pressure. Then close the acetylene control valve on the torch handle. See figures E and L

13. Hold the torch handle (parts B1-B10) in one hand and the flint lighter (D9) in the other hand. See figure M.

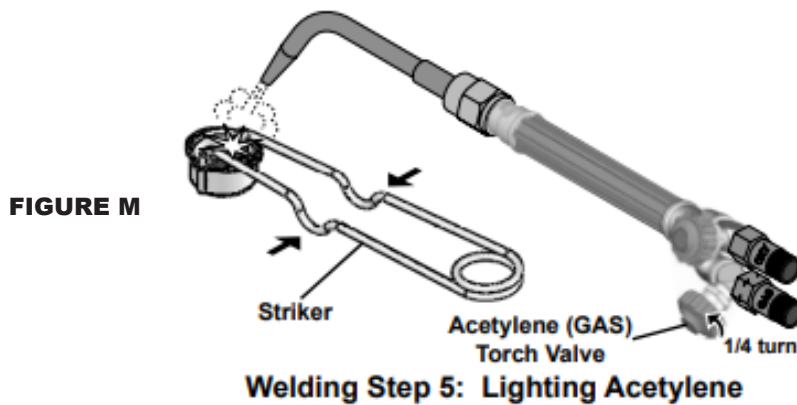

14. Open the acetylene control valve (B8 and AC label B10) about a 1/4 turn and ignite the acetylene gas coming out of the nozzle (part D3, D6) **Always point the nozzle away from other people when lighting.**

15. Slowly open the acetylene control valve (B8 and AC label B10) further until the smoke subsides and the flame jumps away from the end of the nozzle (part D3, D6) slightly. See figure M

16. Slowly open the oxygen control valve (B8 with OX label B9) until a brilliant neutral flame is reached. If the flame has a smooth inner cone, the flame is called neutral. See figure N

Always use the appropriate welding goggles or welding helmet when welding or cutting.

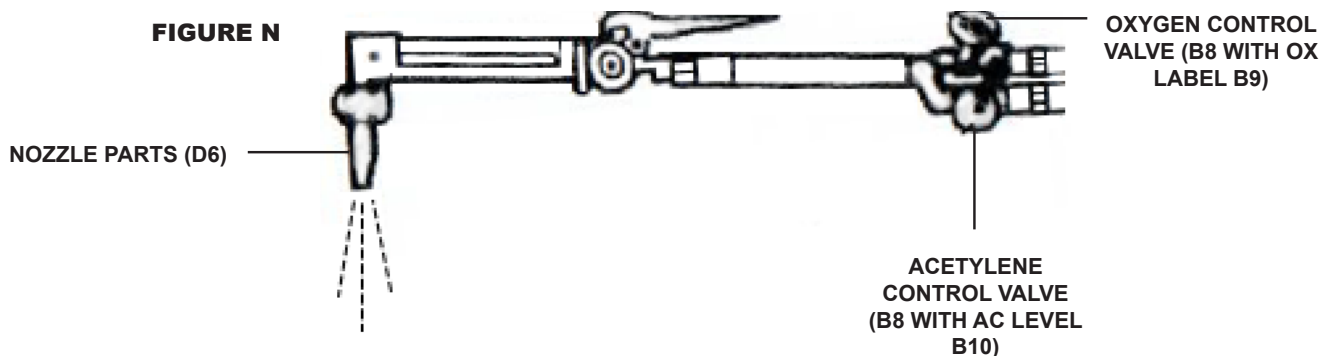

MAINTENANCE

17. Once the welding or cutting job is completed, turn off the oxygen control valve (B8 with OX label B9) Then turn off the acetylene control valve (B8 with AC label B10)

NOTE: Reversal of this procedure may cause damage to the torch handle (parts B1-B10. See figure N

18. Shut off both cylinder valves. See figure E

19. Drain the gas from the oxygen regulator parts (A1-A20E) by opening the oxygen control valve (B8 with OX label B9) Repeat this step on the acetylene side. See figure N

20. Release the pressure on the acetylene and oxygen regulators by turning their pressure adjusting screws (18, A18) counter-clockwise. See figure E

INSPECTION, MAINTENANCE AND CLEANING



Make sure the welding kit is cool to the touch and disconnected from its oxygen and acetylene cylinders before performing any inspection, maintenance or cleaning procedures.

1. **BEFORE EACH USE**, inspect the general condition of the welding kit. Check for loose screws, misalignment or binding of moving parts, cracked or broken parts, damaged welding hoses and any other condition that may affect its safe operation. If a problem occurs, have the problem corrected before further use. **DO NOT USE DAMAGED EQUIPMENT.**

2. **PERIODICALLY**, Use the tip cleaner (D7) to clean out dirt and debris from the nozzles (parts D3, D6) make sure to use the correct size tip cleaner for each individual nozzle. See assembly diagram

3. **TO CLEAN**, use a cloth. If necessary, a mild detergent may be used. Do not immerse any part of the welding kit in liquid. **Do not use solvents or other flammable agents to clean the welding kit.**

Troubleshooting

Problem	Possible Causes	Likely Solutions
Before turning on Torch, gas odor is noticed.	1. Hose connections loose. 2. Crack in hose. 3. Cylinder leak at neck.	1. Tighten all connections. 2. Check hoses. If any cracks are found, replace entire hose. DO NOT PATCH OR TAPE GAS HOSES. 3. Check neck area of cylinders. If cracks or damage are found, do not use. Secure upright, in a well-ventilated area, well away from sources of ignition. Contact gas supplier IMMEDIATELY. Replace cylinders before proceeding with work.
Flame is irregular.	1. Tip clogged or dirty. 2. Gas low.	1. Close gas, acetylene first, then oxygen. Let Torch cool completely. Remove Tip, check for dirt and debris. Use tip cleaner to clean Tip or replace if necessary. 2. Check gas level and refill if needed.

PARTS LIST

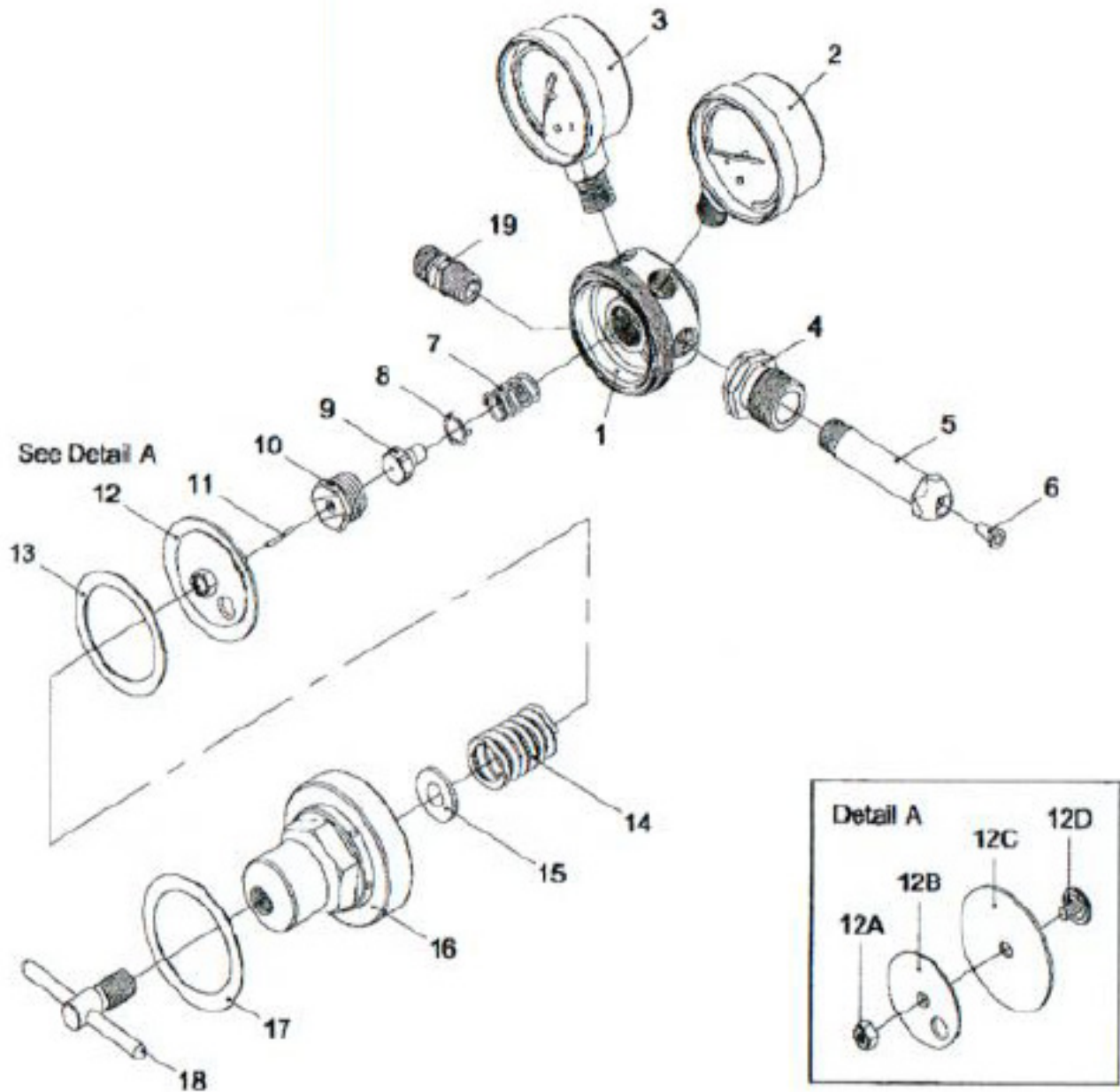

ACETYLENE REGULATOR PARTS LIST

#	DESCRIPTION	#	DESCRIPTION
1	BODY	12A	NUT
2	H.P. GAUGE	12B	DIAPHRAGM PLATE
3	L. P. GAUGE	12C	DIAPHRAGM
4	INLET NUT	12D	CENTRALIZER
5	INLET SPIGOT	13	GASKET
6	FILTER	14	ADJUSTING SPRING
7	VALVE SPRING	15	SPRING BUTTON
8	ANTI-VIBRATOR	16	BONNET
9	VALVE	17	LABEL
10	NOZZLE	18	ADJUSTING SCREW "T" BAR
11	PLUNGER	19	OUTLET ADAPTER
12	DIAPHRAGM ASSEMBLY		

NOTE: Some parts are listed and shown for illustrations purposes only and are not available individually as parts.

PARTS

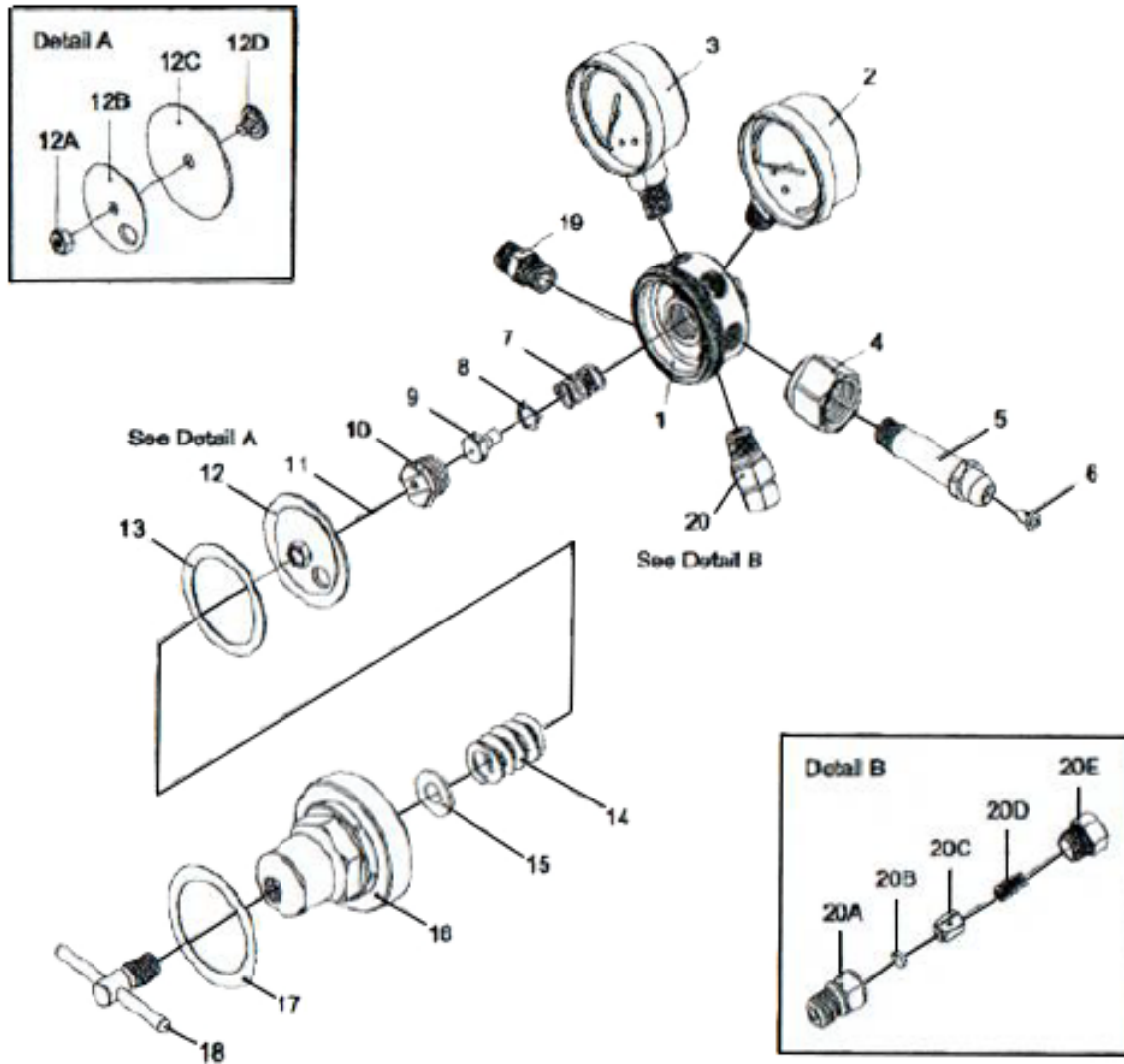

OXYGEN REGULATOR PARTS LIST

#	DESCRIPTION	#	DESCRIPTION
1	BODY	12D	CENTRALIZER
2	H.P. GAUGE	13	GASKET
3	L.P. GAUGE	14	ADJUSTING SPRING
4	INLET NUT	15	SPRING BUTTON
5	INLET SPIGOT	16	BONNET
6	FILTER	17	LABEL
7	VALVE SPRING	18	ADJUSTING SCREW "T" BAR
8	ANTI-VIBRATOR	19	OUTLET ADAPTER
9	VALVE	20	SAFETY VALVE
10	NOZZLE	20A	SAFETY BODY
11	PLUNGER	20B	SAFETY RUBBER
12	DIAPHRAGM ASSEMBLY	20C	SAFETY SEAT
12A	NUT	20D	SAFETY SPRING
12B	DIAPHRAGM PLATE	20E	SAFETY CAP
12C	DIAPHRAGM		

PARTS

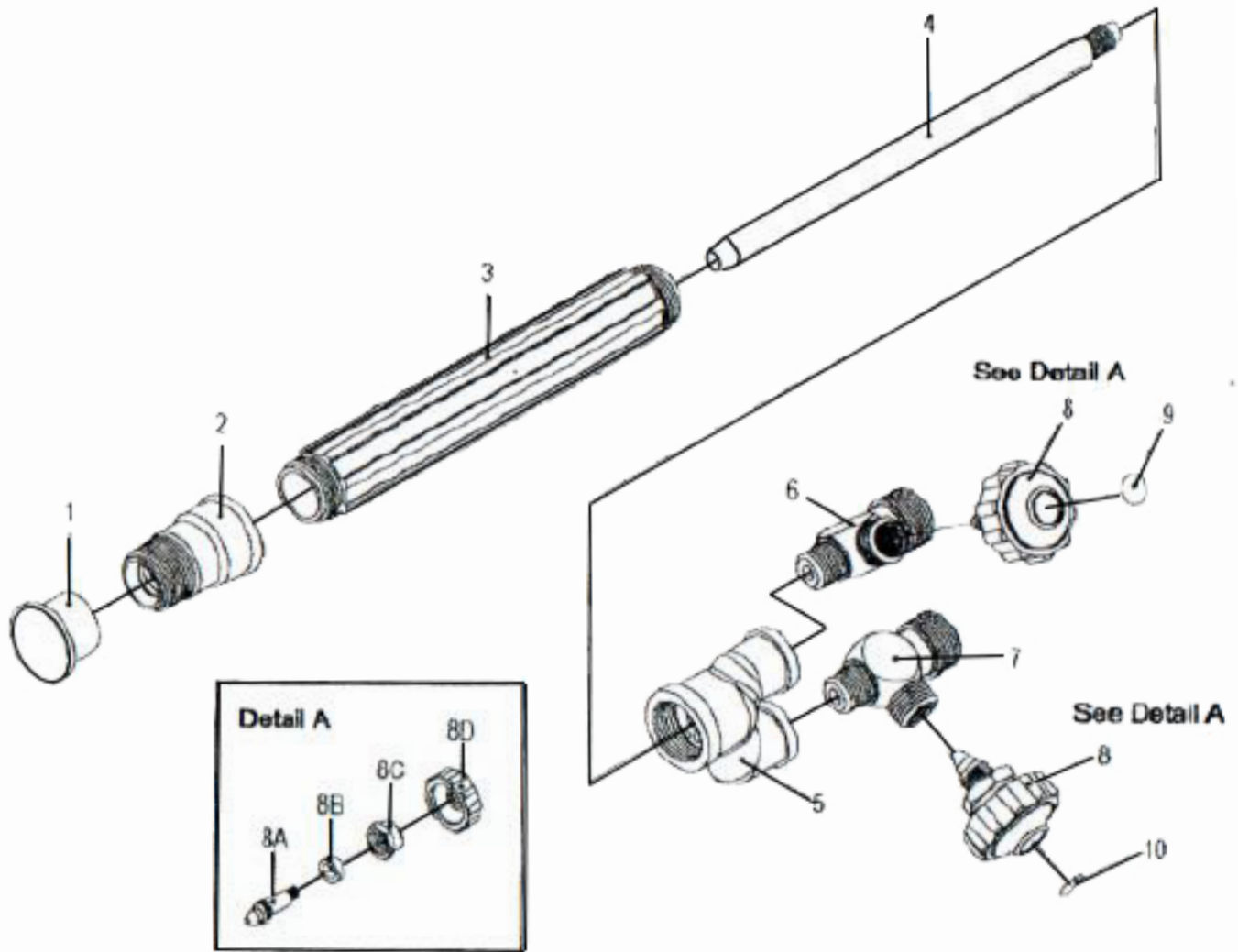

TORCH HANDLE PARTS LIST

#	DESCRIPTION
1	COVER
2	TORCH HEAD
3	HANDLE
4	INNER TUBE
5	TAIL
6	OXYGEN VALVE BODY
7	GAS VALVE BODY
8	VALVE STEM ASSEMBLY
8A	VALVE STEM
8B	WASHER
8C	NUT
8D	ADJUSTING KNOB
9	LABEL OX
10	LABEL AC

NOTE: Some parts are listed and shown for illustrations purposes only and are not available individually as parts.

PARTS

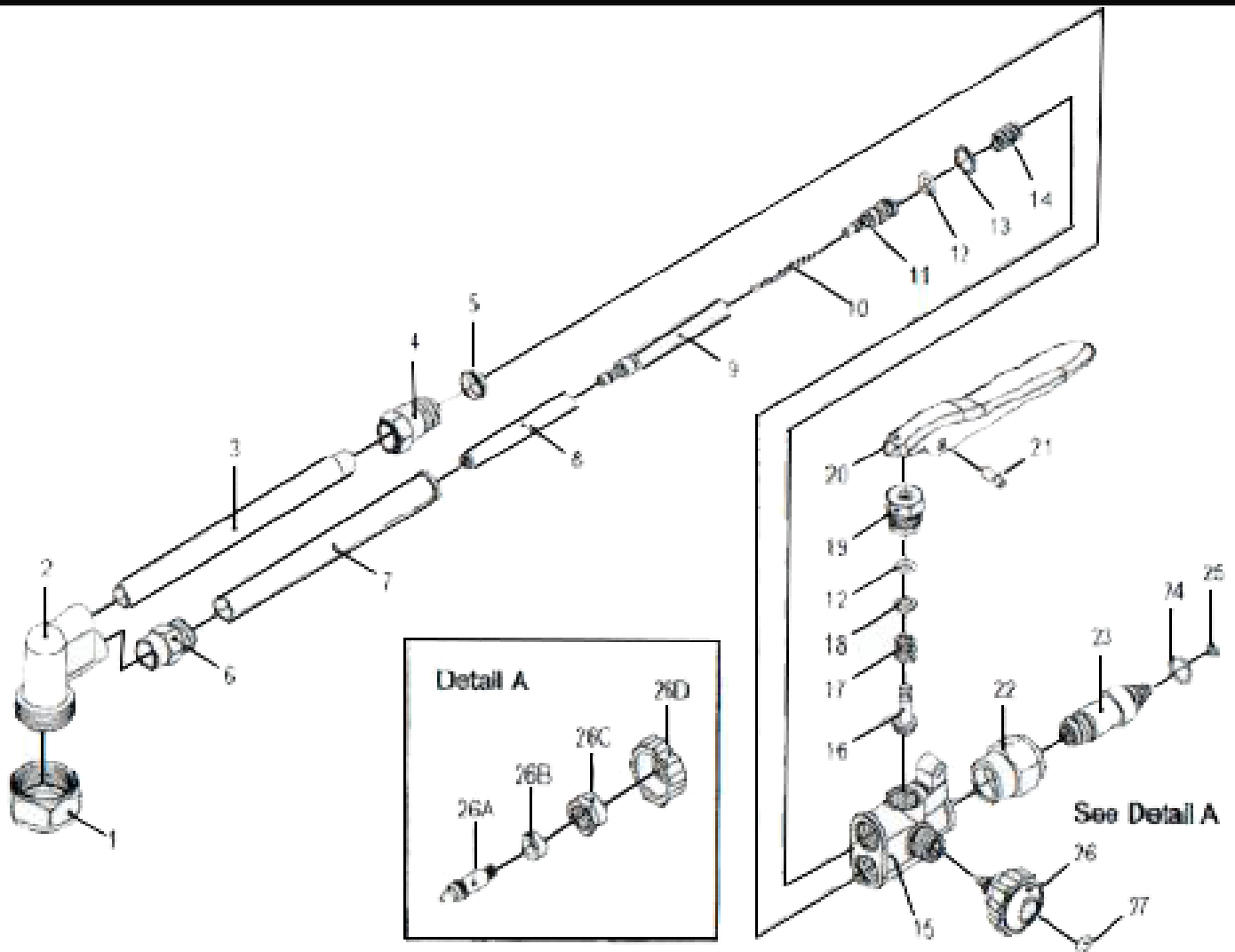

CUTTING ATTACHMENT PARTS LIST

#	DESCRIPTION	#	DESCRIPTION
1	TIP NUT	17	HP SPRING
2	HEAD	18	WASHER
3	OXYGEN TUBE	19	VALVE CAP
4	NUT	20	LEVER
5	FEMALE	21	SPIRAL PIN
6	NUT	22	COUPLING NUT
7	FUEL TUBE	23	CONE END
8	INNER TUBE A	24	O-RING - BIG
9	INNER TUBE B	25	O-RING - SMALL
10	SPIRO	26	VALVE STEM ASSEMBLY
11	INNER TUBE C	26A	VALVE STEM ASSEMBLY
12	O-RING	26B	WASHER
13	WASHER - TEFLON	26C	NUT
14	SPRING	26D	ADJUSTING KNOB
15	BODY	27	LABEL OX
16	VALVE		

NOTE: Some parts are listed and shown for illustrations purposes only and are not available individually as parts.

PARTS

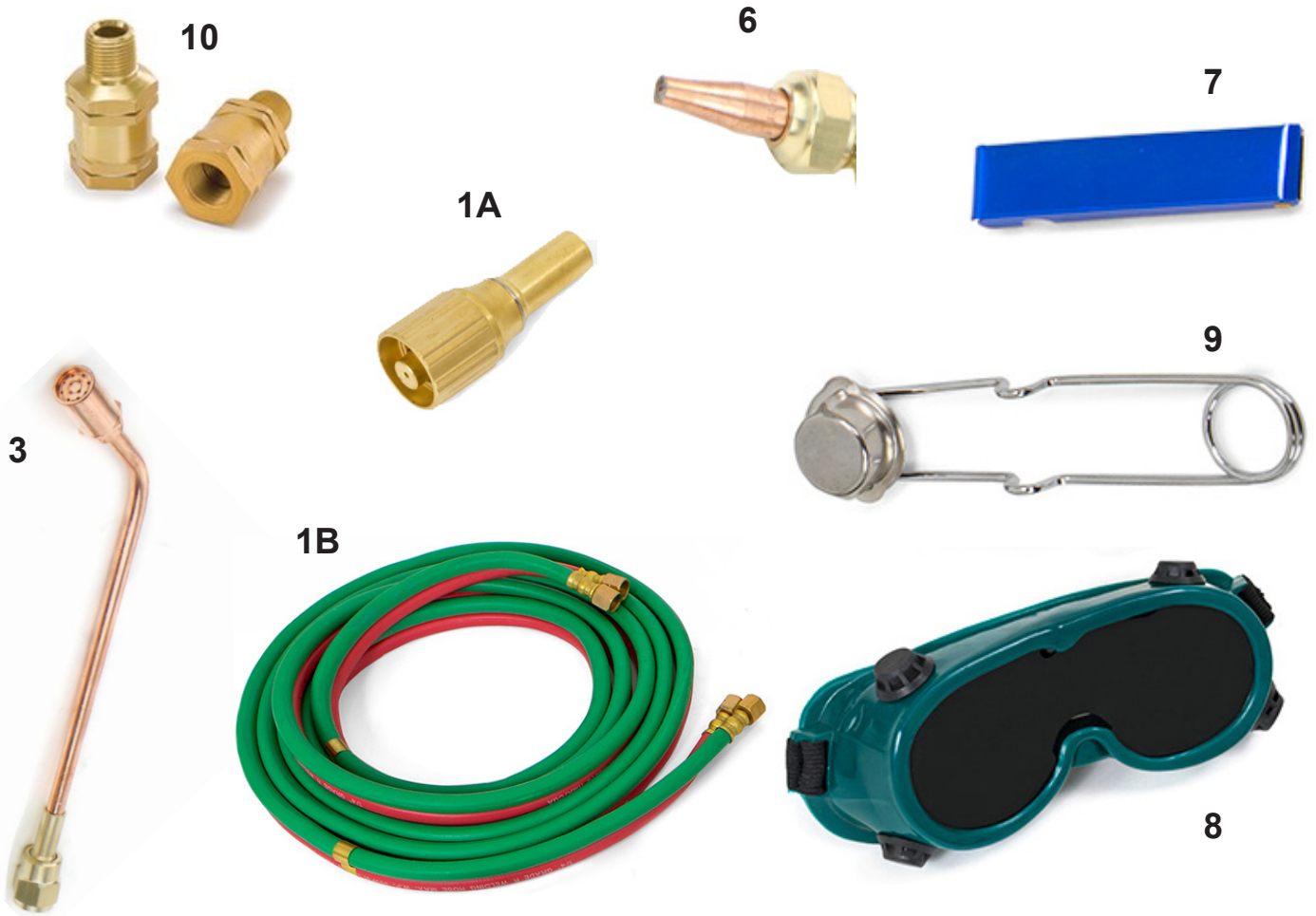

ACCESSORY PARTS LIST

#	DESCRIPTION
1A	GREEN & RED WELDING HOSE
3	WELDING NOZZLE
6	CUTTING NOZZLE
7	TIP CLEANER
8	WELDING GLASSES
9	FLINT LIGHTER
10	OXYGEN & FUEL CHECK VALVES

NOTE: Some parts are listed and shown for illustrations purposes only and are not available individually as parts.

DISCLAIMER

PLEASE READ THE FOLLOWING CAREFULLY

THE MANUFACTURER AND/OR DISTRIBUTOR HAS PROVIDED THE PARTS LIST AND ASSEMBLY DIAGRAM IN THIS MANUAL AS A REFERENCE TOOL ONLY. NEITHER THE MANUFACTURER OR DISTRIBUTOR MAKES ANY REPRESENTATION OR WARRANTY OF ANY KIND TO THE BUYER THAT HE OR SHE IS QUALIFIED TO MAKE ANY REPAIRS TO THE PRODUCT, OR THAT HE OR SHE IS QUALIFIED TO REPLACE ANY PARTS OF THE PRODUCT. IN FACT, THE MANUFACTURER AND/OR DISTRIBUTOR EXPRESSLY STATES THAT ALL REPAIRS AND PARTS REPLACEMENTS SHOULD BE UNDERTAKEN BY CERTIFIED AND LICENSED TECHNICIANS, AND NOT BY THE BUYER. THE BUYER ASSUMES ALL RISK AND LIABILITY ARISING OUT OF HIS OR HER REPAIRS TO THE ORIGINAL PRODUCT OR REPLACEMENT PARTS THERETO, OR ARISING OUT OF HIS OR HER INSTALLATION OF REPLACEMENT PARTS THERETO.

Record Product's Serial Number Here: _____

Note: If product has no serial number, record month and year of purchase instead.

Note: Some parts are listed and shown for illustration purposes only and are not available individually as replacement parts.



SAVE THESE INSTRUCTIONS.

Questions, Problems or Missing Parts?

Before returning to a retailer, our exceptional customer service is available to help.

Call Us: 909.628.4900

Hours of Operation: 9 to 4pm PST, Monday - Friday

Email: info@starktoolsusa.com



PRODUCT MADE IN CHINA