

# **X**TREMEPOWER **US**

**Gasoline Engine**

**SKU: 62037**

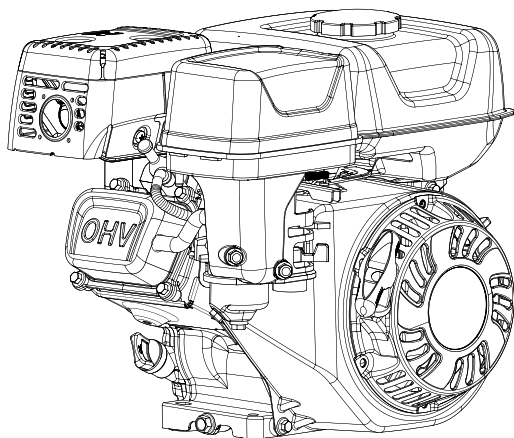

## **Owner's Manual**

**IMPORTANT:**

Keep this manual for safety warnings and precautions, assembly, operating, inspection and maintenance procedures.

Read all precautions and instructions carefully before operating this engine.

---

This manual should be considered a permanent part of this engine and should remain with the engine if resold.

Chongqing Rato reserves the right to discontinue, change and improve its products at any time without notice or obligation to the purchaser.





## SAFETY PRECAUTIONS



**A hazard that could result in death or serious injury.**



**A hazard that could result in minor or moderate personal injury.**

**NOTICE**

**A hazard that could result in property damage.**

**NOTE**

**Important installation, operation, or maintenance information.**

 **WARNING**



Check that there is not any fuel spilling or fuel leakage. Filling fuel before starting engine

 **WARNING**



Please read the user's manual carefully before operating the engine

 **WARNING**

Hot exhaust can burn you. Stay away if engine has been running.

## CONTENTS

SAFETY PRECAUTIONS .....	2
I. OPERATING PRECAUTIONS .....	4
II. PARTS DESCRIPTION .....	6
III. PRE-OPERATE INSPECTION .....	7
IV. STARTING THE ENGINE .....	10
V. RUNNING THE ENGINE .....	12
VI. STOPPING THE ENGINE .....	15
VII. EXHAUST CONTROL SYSTEM .....	16
VIII. MAINTENANCE .....	17
IX. TRANSPORT AND STORAGE .....	22
X. TROUBLESHOOTING .....	24
XI. SPECIFICATIONS .....	26
XII. ELECTRIC DIAGRAM .....	27
XIII. WEARING PARTS AND ACCESSORIES LIST .....	28

## I. OPERATING PRECAUTIONS



**Read all instructions carefully before operating this engine. Failure to follow all instructions may result in fire, serious injury or death.**

The warnings and precautions listed in this manual cannot cover all possible conditions and situations that may occur. It must be understood by the operator that common sense and caution are factors which cannot be built into this product, but must be supplied by the operator.

### 1. CARBON MONOXIDE HAZARD

**Using an engine indoors can kill you in minutes.**

Engine exhaust contains carbon monoxide. This is a poison you cannot see or smell. NEVER use inside a home or garage, even if doors and windows are open. Only use outside and far away from windows, doors and vents.

2. Strictly set the engine according to the regulated power on the owner's manual. Do not overload, overspeed the engine or run it with low load and at low speed in a long time.
3. Fire Hazard! Do not fill fuel tank while engine is running. Do not operate the engine if gasoline has been spilled. Clean the spilled gasoline before starting engine. Do not operate near open flame.
4. Hot parts can cause severe burns. Do not touch engine during use. Let engine cool down after use.
5. Keep children away from this engine, especially while it is running.

## OPERATING PRECAUTIONS

---

6. Use proper transport devices to avoid rolling, slipping and tilting when transporting the engine.
7. Use recommended oil type and fuel type.
8. Wear ear protection when operating or working around the engine while it is running.
9. Do not cover the engine while it is running.
10. Follow the maintenance schedule to keep the engine in good working condition.

## II. PARTS DESCRIPTION

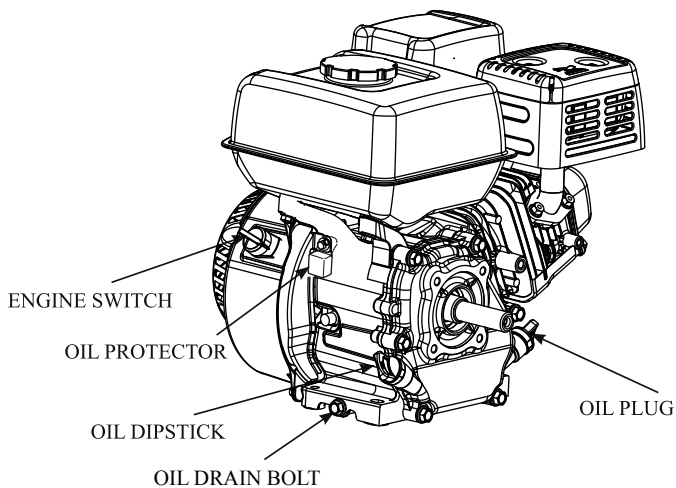
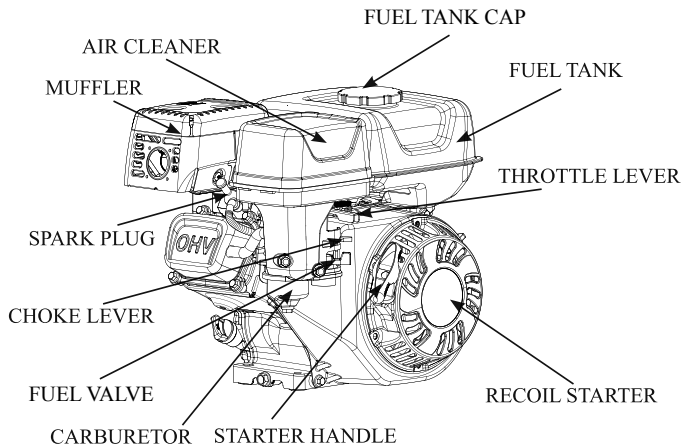

## III. PRE-OPERATE INSPECTION

### 1. ENGINE OIL

**NOTICE** Your Warranty is void if the engines is not properly filled with oil before each use. Running the engine with a low oil level or no oil can cause severe engine damage.

The oil alert system(if equipped) will automatically stop the engine before the oil level falls below safe limit. However, to avoid an unexpected shutdown, be sure to check the engine oil before starting the engine.

Use 4-stroke engine oil. API (American Petroleum Institute) service class SJ or higher are acceptable.

SAE 10W-30 oil is recommended for general use.

The SAE Viscosity Grades chart below shows other viscosities to use in different average temperatures.

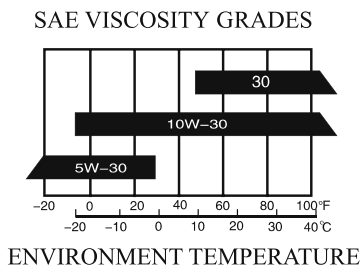

### CHECKING AND FILLING OIL

- 1) Make sure the engine is stopped and in a level position.
- 2) Remove the dipstick and clean it.
- 3) Reinsert the dipstick into the oil filling hole without threading it in, and remove it to check oil level.
- 4) If the oil level is too low, add the recommended engine oil up to the upper limit level.
- 5) Reinstall the dipstick.
- 6) Lubrication oil capacity: 62037 0.5L



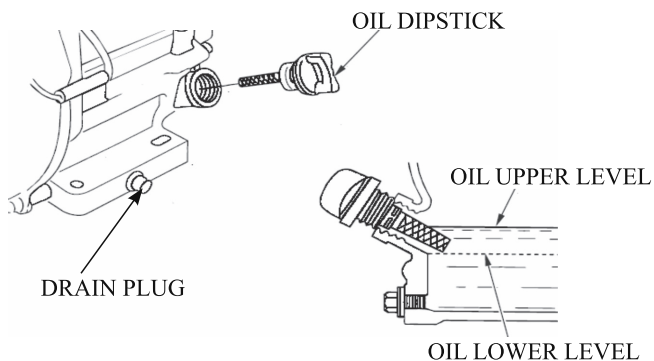

## 2. AIR CLEANER

Remove the air cleaner cover and inspect the air filter element. Clean or replace the dirty filter element if necessary.

### NOTICE

Operating the engine without an air filter or with a damaged air filter will damage the engine. This type of damage is not covered by the Warranty.

## 3. CHECKING AND ADDING FUEL

### NOTICE

Use clean, fresh, regular unleaded gasoline with a minimum octane rating of 87 and an ethanol content of 10% or less by volume. (E10) Any damages or hazards caused by using improper gasoline are not covered by the Warranty.

- 1) Remove the fuel tank cap and check fuel level.
- 2) Slowly add gasoline to the tank. Recommended fuel level is 1 inch below the filling port.

 **WARNING**

- 1) **Gasoline and gasoline vapors are highly flammable and explosive. Fire or explosion can cause severe burns or death.**
- 2) **Fill the tank in a well-ventilated area with the engine stopped and away from heat and ignition sources.**
- 3) **Do not fill tank indoors.**
- 4) **Do not mix oil and gasoline.**
- 5) **Do not fill tank when engine is running or hot.**
- 6) **Do not overfill the fuel tank. Gasoline expands when ambient temperature rise.**
- 7) **Gasoline is a skin irritant and needs to be cleaned up immediately if spilled on skin or cloths.**
- 8) **Keep out of reach of children.**

Fuel tank capacity:      62037    2.6L

## IV.STARTING THE ENGINE

1.Move the fuel valve to the "ON" position.

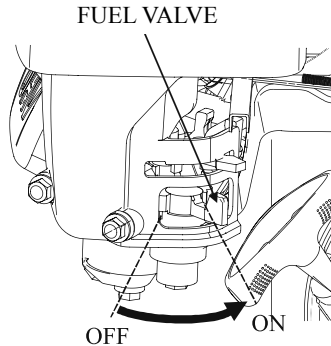

2. To start a cold engine, move the choke lever to the CHOCK position. To restart a warm engine, leave the choke lever in the RUN position.

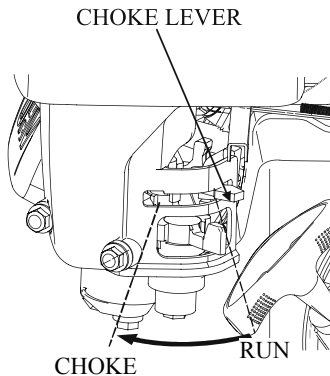

# STARTING THE ENGINE

3. Slide the throttle lever to 1/3 away from low speed position(the "Turtle").

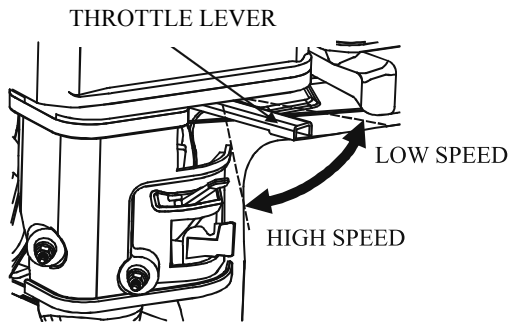

4. Start the engine

Recoil starter:

Turn the engine switch to the "ON" (OPEN) position.

Pull the starter grip gently until resistance is felt. Allow cable to retract fully and then pull it quickly. Repeat until the engine starts.

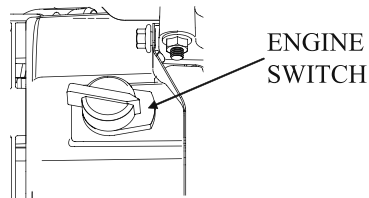

## NOTICE

**Don't allow the starter grip to snap back against the engine.**  
**Hold it as it recoils so it doesn't hit the engine.**

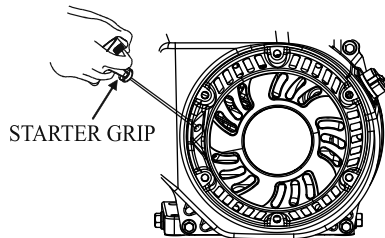

## V.RUNNING THE ENGINE

1. Allow the engine to run for several seconds. Move the choke lever slowly to the "RUN" position.

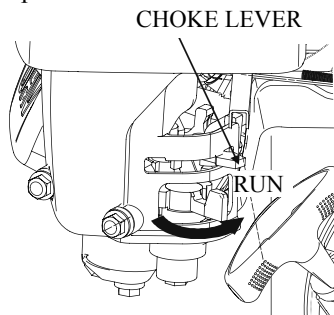

2. Adjust the throttle lever as needed.

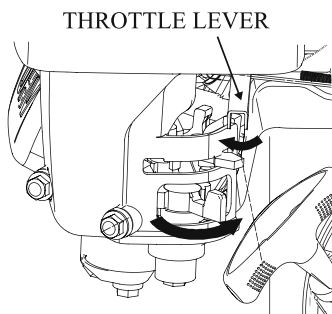

## ENGINE OILALARM

The engine oil alarm system is designed to function when engine oil in the crankcase is insufficient. Running the engine with no oil or with a low oil level can cause severe damage to the engine. The engine oil alert system will automatically stop the engine when the oil falls below the threshold level.

## NOTE

**If you can not start the engine, check the engine oil level first before any other inspection.**

## **HIGH ALTITUDE KIT REPLACEMENT FOR EPAIII ENGINES**

**3000-6000ft. / 6000-8000ft. of elevation**

At high altitude, the standard carburetor air-fuel mixture will be too rich. Performance will decrease and fuel consumption will increase. A very rich mixture will also foul the spark plug and cause hard starting. Operation at an altitude that differs from that at which this engine was certified, for extended periods of time, may increase emissions.

The fuel system on this engine/equipment may be influenced by operation at higher altitudes. Proper operation can be ensured by installing an altitude kit when required. See the table below to determine when an altitude kit is required. Operating this engine/equipment without the proper altitude kit installed may increase the engine's emissions and decrease fuel economy and performance. Kits may be obtained from any dealer, and should be installed by a qualified individual.

Equipment *	Fuel	Altitude Range**	Kit Part Number
Equipment with engines above 80cc	Gasoline	0 – 3000 ft	Not Required
		3000 – 6000 ft	Altitude kit 1#
		6000 – 8000 ft	Altitude kit 2#
* Engine, Generator Set, Pressure Washer, Walk-Behind Lawnmower, Compressor, Pump, Tiller etc.			
** Elevation above sea level.			

- This high altitude jet is to be used at elevations above 3000 feet.
- At elevations above 8000 feet, the engine/equipment may experience decreased performance, even with the high altitude kit.
- If a carburetor is replaced, the proper high altitude kit jet will need to be installed into the replacement carburetor.



**WARNING!** To prevent serious injury from fire: Follow the kit procedures in a well-ventilated area away from ignition sources. If the engine is hot from use, shut the engine off and wait for it to cool before proceeding.

**NOTICE:** The warranty may be void if necessary adjustments are not made for high altitude use.

## VI.STOPPING THE ENGINE

1. Turn the engine switch off if an emergency occurs.
  
2. Under normal conditions, please use the following procedure:
  - i. Move the throttle lever to the low speed position(the "Turtle").
  - ii. Turn the engine switch off.
  - iii. Move the fuel valve to OFF position.

### NOTICE

**Sudden stop at high-speed and heavy-load condition will cause engine damage.**

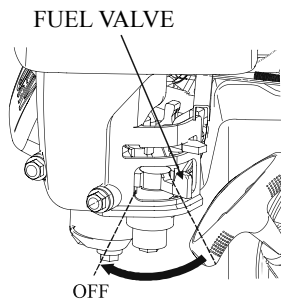



---

## VII. EXHAUST CONTROL SYSTEM

Running engine can produce carbon monoxide, hydrocarbon and oxides of nitrogen. carbon monoxide is toxic. Hydrocarbon and oxides of nitrogen can react chemically to produce smoke.

To keep the exhaust of your engine within the EPA emission standard, pay special attention the following:

### 1. Maintenance

The owner/operator should strictly follow the Maintenance schedule and complete all scheduled maintenance in a timely manner. If the engine always works under severe conditions, maintenance should be performed more frequently.

### 2. Problems affecting exhaust emissions:

- a. Difficult starting or stopping
- b. Unstable idling speed
- c. Abnormal black smoke or fuel consumption
- d. Poor ignition, sparks or backfire
- e. Premature ignition

If you are experiencing any of above problems, contact an authorized service dealer for help.

## VIII. MAINTENANCE

1.The engine must be properly maintained to ensure its operation be safe, economy and trouble-free, as well as eco-friendly.

In order to keep your gasoline engine in good working condition, it must be periodically serviced. The following maintenance schedule and routine inspection procedures must be carefully followed:

Items		Frequency	Each time	First 1 month or first 20hrs of operation	Thereafter, every 3 months or every 50hrs of operation	Every year or every 100 hrs of operation
Engine oil	Check- Refill		√			
	Replace			√	√	
Reduction gear oil(if equipped)	Oil level check		√			
	Replace			√	√	
Air filter element	Check		√			
	Clean			√		
	Replace				√	
Deposit Cup( if equipped)	Clean					√
Spark Plug	Check - adjust					√*
Spark arrester	Clean				√	
Idling ( if equipped)**	Check - adjust					√
Valve clearance **	Check-adjust					√
Fuel tank & fuel filter **	Clean					√
Fuel line	Check	Every 2 years( change if necessary)				
Cylinder head, piston	Clean up carbon **			< 225cc, Every 125hrs	≥ 225cc, Every 250hrs	
* These items should be replaced if replacement needed.						
** These items should be maintained and repaired by our authorized dealer, unless the owner has appropriate tools and is proficient with mechanical maintenance.						

## NOTICE

- If the gasoline engine frequently work under high temperature or heavy load, change the oil every 25 hours.
- If the engine frequently work under dusty or other severe circumstances, clean the air filter element every 10 hours; If necessary, change the air filter element every 25 hours.

## WARNING

**Stop the engine before servicing. Put the engine on a level surface and remove the spark plug cap to prevent the engine from starting. Do not operate the engine in a poorly ventilated room or other enclosed area. Be sure to keep good ventilation in working area. The exhaust from the engine may contain poisonous CO, inhalation can cause shock, unconsciousness and even death.**

## 2. Maintenance method

### 1) Engine oil change

- a. Place the stopped engine on a flat and level surface.
- b. Place a drain pan underneath the crankcase's drain plug.
- c. Remove the oil drain bolt and tilt the engine slightly to drain the oil.
- d. Reinstall the oil drain bolt and tighten it.
- e. Remove the oil dipstick and fill the appropriate type of oil until the oil level is at the upper limit level.
- f. Thread the dipstick back and clean the area around it.

#### NOTE

**For the sake of environmental protection, we suggest you collect the drained oil in a sealed container and take it to a designated recycle bin.**

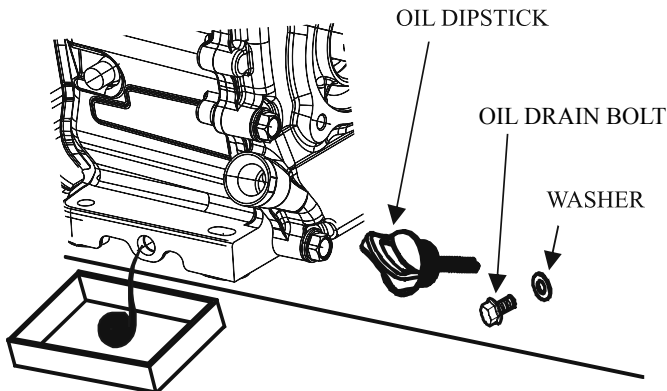

## 2) Maintenance of air cleaner

Air filter/air cleaner is to protect the engine by filtering dust and debris from the intake air. A dirty air filter will restrict air flow to the carburetor, reducing engine performance. If you operate the engine in very dusty areas, clean the air filter more often than specified in the MAINTENANCE schedule.

### WARNING

**Never clean the air cleaner element with gasoline or low flash-point detergents, or explosion may happen.**

### NOTICE

**Running the engine without an air filter or with a damaged air filter can cause engine damage and will void the Warranty.**

- a. Remove the air cleaner cover.
- b. Remove the foam or paper element.
- c. Clean the filter element as described below:

For paper filter element:

In a well-ventilated area away from bystanders, use pressurized air to blow dust out of the air filter. If this does not get the filter clean, replace it.

For foam element:

Wash the element in warm water and mild detergent several times. Squeeze thoroughly dry in a clean cloth. Soak the filter in lightweight oil briefly, then squeeze out the excess oil.

- d. Place the new filter or cleaned filter in the assembly and secure the cover before use.

## 3) Spark plug maintenance

Spark plug type: F6RTC, F6TC or equivalent types.

- Remove the spark plug cap from the spark plug.
- Use a spark plug socket tool to remove the plug.
- Inspect the electrode on the plug. Clean out debris around the spark plug or replace it with a new one if necessary.
- Make sure the spark plug gap is 0.7~0.8mm.
- Firmly reinstall the plug.
- Attach the spark plug cap to the spark plug.

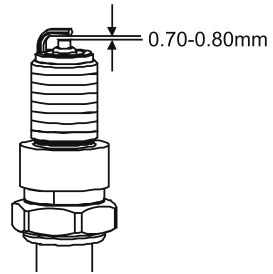
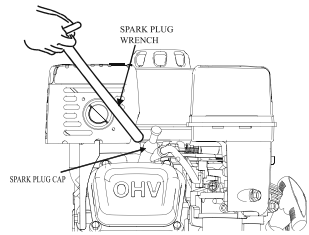

### WARNING

**Be careful of unintentional contact with the hot surface around the spark plug area. Allow the engine to cool before any maintenance.**

### NOTICE

**Using an incorrect spark plug may damage the engine.**

**Tighten the spark plug properly. If loose, the spark plug will cause overheat. If overtightened, the threads in the engine block will be damaged.**

## IX. TRANSPORT AND STORAGE

Before transporting the engine, allow the engine to properly cool and make sure that the fuel valve is in the OFF position.

### NOTICE

**Allow the engine to cool completely before storage.**

For short-term storage (up to 1 month)

1. Turn off the fuel supply at the fuel valve.
2. Use a funnel under the carburetor drain bolt to avoid spillage.
3. Remove the carburetor drain bolt to drain the fuel.

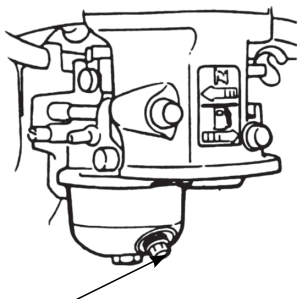

CARBURETOR DRAIN BOLT

For long-term storage (more than 1 month)

1. Turn the fuel valve to ON position.
2. Place a fuel container under the carburetor. Use a funnel under the carburetor drain bolt to avoid spillage. Remove the drain bolt to empty the fuel tank.
3. Replace and tighten the carburetor drain bolt. Be sure to properly dispose of the drained fuel according to local guidelines.

### WARNING

**Gasoline and gasoline vapors are highly flammable and extremely explosive. Store away from sparks, open flames, pilot light, heat or other sources of ignition.**

### Removing from storage

If the gasoline tank and carburetor have been properly emptied of all gasoline prior to the engine being stored, follow the blow steps when removing from storage.

1. Add fuel according to CHECKING AND ADDING FUEL.
2. Turn the fuel valve to ON position.
3. After 5 minutes check the carburetor and air filter areas for any leakage gasoline. If leakage occurs, clean or replace the carburetor. If no leakage, turn the fuel valve to OFF position.
4. Add engine oil according to CHECKING AND FILLING OIL.
5. Check the air filter of any obstructions. Clean or replace the air filter if necessary.
6. Start the engine according to the instruction.



## X.TROUBLESHOOTING

PROBLEM	CAUSE	SOLUTION
Difficult Engine Starting or Engine Not Start.	No fuel or fuel valve closed.	Add fuel or turn on the fuel valve.
	For cold engine, choke not in CHOKE position.	Move chock lever to CHOCK position.
	Wrong fuel type.	Use clean, fresh, regular unleaded gasoline with a minimum octane rating of 87 and an ethanol content5 of 10% or less by volume. (E10)
	Water in fuel or old (deteriorated) fuel.	Drain fuel and replace with fresh fuel.
	Carburetor not primed.	Pull on starter grip to prime.
	Dirty fuel passageways.	Clean out passageways using fuel additive.
	Engine is flooded.	Wait 5 minutes. Move choke to RUN position, pull the starter grip and repeat until engine starts.
	Clogged fuel filter.	Replace with a new filter.
	Spark plug cap not connected securely.	Tighten the spark plug cap.
	Spark plug electrode wet or dirty.	Clean spark plug.
	Incorrect spark plug gap.	Adjust spark plug gap or replace..
	Damaged spark plug cap.	Replace a new cap.
	Incorrect spark timing or faulty ignition system.	Have qualified technician repair.
	Loosen or broken spark plug. (Hissing occurs)	Tighten spark plug or replace with a new spark plug.
	Loosen or broken cylinder head or damaged head gasket. ( Hissing occurs)	Tighten head or replace with a new head gasket.
Engine valves misadjusted or stuck.	Have a qualified technician repair.	

## TROUBLESHOOTING

PROBLEM	CAUSE	SOLUTION
Engine Runs Roughly	Choke in the wrong position.	Move choke lever to the RUN position.
	Dirty air filter.	Clean or replace with a new one.
	Dirty fuel valve.	Clean the fuel valve.
	Clogged spark arrester.	Clean spark arrester.
Engine Stops Suddenly	Low oil level.	Fill engine oil to proper level.
	Empty fuel tank or wrong fuel type.	See CHECK AND ADDING FUEL.
	Wrong fuel tank cap.	Replace fuel cap.
	Disconnected spark plug cap.	Secure spark plug cap.
Engine stops under Heavy load	Dirty air filter.	Clean or replace with a new one.
	Engine running cold.	Allow engine warms up before operation..
Engine Knocks	Engine overloaded.	Do not exceed rating load.
	Wrong fuel type.	See CHECK AND ADDING FUEL.
Engine Backfires	Impure gasoline or wrong fuel type.	Drain the old fuel and refill with fresh gasoline. See CHECK AND ADDING FUEL.
	Intake valve stuck or overheated engine.	Have a qualified technician diagnose the engine.
	Incorrect timing.	Check engine timing.
Engine Overheated	Low engine oil level.	Add engine oil to proper level.
	Clogged exhaust pipe.	Clean exhaust pipe.
	Cooling fan blocked.	Clean cooling fan.
Other	<b>Contact an authorized service dealer for technical support.</b>	

## XI.SPECIFICATIONS

### 1) MAIN SPECIFICATION

Model	62037
Specification	
L×W×H (mm)	360×290×325
Dry Weight (kg)	12.5
Gasoline Engine Type	4-Stroke,OHV,Single Cylinder
Displacement(ml)	209
Compression Ratio	8.2:1
Bore × Stroke(mm)	74.5×48
Maximum Output Power (kW/r/min)	4.3/3600
Maximum Torque (N.m/r/min)	12.4/2500
Cooling System	Forced Air-cooled
Ignition System	Transistorized Magneto Ignition(TCI)
Spark Plug	F6TC or F6RTC
Lubrication System	Forced Splash
PTO Shaft Rotation	Counterclockwise
Spark Plug Gap	0.7- 0.8mm
Valve clearance	Intake: 0.05-0.10mm Exhaust: 0.05-0.10mm

### 2) TORQUE OF IMPORTANT BOLTS

	Specifications	Torque Valve	
		N· m	Kg· m
Connection-Rod Bolt	M7×32(special)	13±1	1.0
Cylinder Head Bolt	M8×60	28±2	1.0
Flywheel Nut	M14×1.5(special)	75±7	7.5
Lock Nut Of Rocker Arm Shaft	M6	10±2	1.0

## XII.ELECTRIC DIAGRAM

Bl	BLACK
Y	YELLOW
G	GREEN

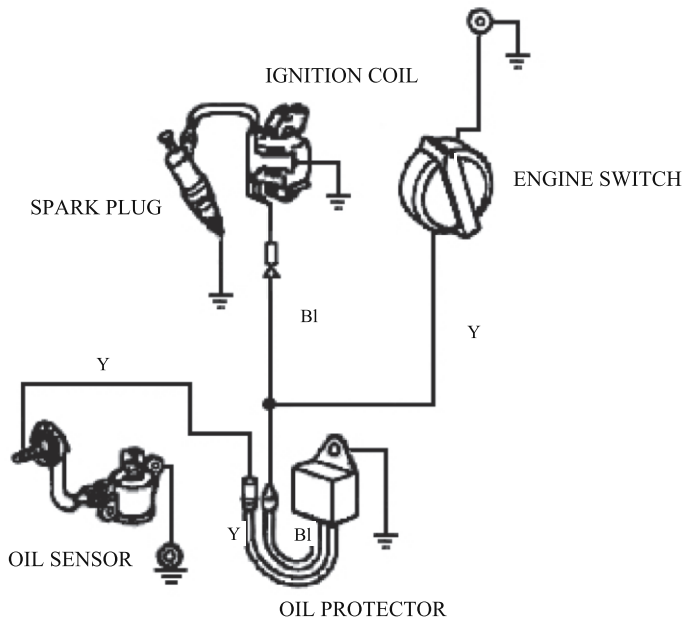

## XIII.WEARING PARTS AND ACCESSORIES LIST

### WEARING PARTS:

CRANKCASE GASKET
CYLINDER HEAD COVER GASKET
CYLINDER HEAD GASKET
CARBURETOR GASKET
CARBURETOR INSULATION GASKET
AIR CLEANER GASKET
EXHAUST VENT GASKET
SPARK PLUG
RECOIL STARTER
SEAL GUIDE
OIL SEALING

### ACCESSORIES:

SOCKET
FORCE BAR

## DISCLAIMER

### *PLEASE READ THE FOLLOWING CAREFULLY*

---

The manufacturer and/or distributor have provided the parts list and assembly diagram in this manual for reference purposes only. They do not make any representation or warranty to the buyer that they are qualified to make repairs to the product or replace any parts of the product. In fact, the manufacturer and/or distributor expressly state that all repairs and parts replacements should be undertaken by certified and licensed technicians, and not by the buyer.

The buyer assumes all risk and liability arising from their repairs to the original product or replacement parts or arising from their installation of replacement parts. It is strongly advised that qualified professionals handle any repairs or replacements to ensure safety and proper functioning of the product. Improper installation and operation may result in injury, property damage, or voiding of warranty. The manufacturer and/or distributor shall not be held responsible for any accidents, damages, or malfunctions resulting from the buyer's installation and operation of the product. It is essential to follow all safety guidelines and recommendations provided in this manual and to seek professional assistance if unsure about the installation or operation procedures.

---

## CUSTOMER SERVICE

If you have any questions about ordering our outdoor furnitures and replacement parts or other furniture products, please feel free to contact us using the following contact information:

### *Customer Service and Technical Support*

**Phone:** (909) 628-0880

**Email:** [customer@xtremepowerusa.com](mailto:customer@xtremepowerusa.com)

**Hours of Operation:** Monday – Friday, 9AM – 4PM (CST)

---