



DRYWALL PANEL ROLLING LIFTER

ITEM: 65044 11FT & 65045 16FT



OWNER'S MANUAL AND SAFETY INSTRUCTIONS

SAVE THIS MANUAL: KEEP THIS MANUAL FOR SAFETY WARNINGS, PRECAUTIONS, ASSEMBLY, OPERATING, INSPECTION, MAINTENANCE AND CLEANING PROCEDURES. WRITE THE PRODUCT'S SERIAL NUMBER ON THE BACK OF THE MANUAL NEAR THE ASSEMBLY DIAGRAM (OR MONTH AND YEAR OF PURCHASE IF PRODUCT HAS NO NUMBER).

FOR QUESTIONS PLEASE CALL OUR CUSTOMER SUPPORT: (909) 628 4900 MON-FRI 9AM TO 3PM PST

SAFETY

The warnings, precautions, and instructions discussed in this instruction manual cannot cover all possible conditions and situations that may occur. It must be understood by the operator that common sense and caution are factors which cannot be built into this product, but must be supplied by the operator. Read carefully and understand all ASSEMBLY AND OPERATION INSTRUCTIONS before operating. Failure to follow the safety rules and other basic safety precautions may result in serious personal injury.

- Keep children away. Children must never be allowed in the work area. **DO NOT** let them handle machines, tools or let them climb on or play with the product.
- Store idle equipment. When not in use, tools must be stored in a dry location to inhibit rust. **ALWAYS** lock up tools and keep out of reach of children.
- **DO NOT** modify this tool and do not use this tool for a purpose for which it was not intended.
- Dress properly. **DO NOT** wear loose clothing or jewelry as they can be caught in moving parts. Protective, electrically non-conductive clothes and non-skid footwear are recommended when working. Wear restrictive hair covering to contain long hair.
- Wear ANSI-approved safety goggles, an ANSI-approved hard hat and heavy-duty work gloves during set up and use.
- **DO NOT** overreach. Keep proper footing and balance at all times. **DO NOT** reach over or across a Panel Hoist while in operation. **DO NOT** walk or stand under Panel Hoist needlessly while in operation.
- Check for damaged parts. Before using any tool, any part that appears damaged should be carefully checked to determine that it will operate properly and perform its intended function. Check for alignment and binding of moving parts; any broken parts or mounting fixtures; and any other condition that may affect proper operation. Any part that is damaged should be properly repaired or replaced by a qualified technician. **DO NOT** use the tool if any control does not operate properly.
- When servicing, use only identical replacement parts. Use of any other parts will void the warranty. Only use accessories intended for use with this tool.
- **DO NOT** operate tool if under the influence of alcohol or drugs. Read warning labels if taking prescription medicine to determine if your judgment or reflexes are impaired while taking drugs. If there is any doubt, **DO NOT** operate the tool.
- Stand clear of the Panel Hoist when raising or lowering a panel. **NEVER** reach through the winch wheel.
- **DO NOT** exceed the Hoist's capacity of 150 lb. Check the manufacturer's documentation to determine the actual weight of panels before attempting to lift them.
- **DO NOT** ride on the Panel Hoist, and never have people or pets in the area while operating Hoist.
- Only use the Hoist to raise/lower one drywall panel at a time. After raising the panel, immediately fix in place using the recommended type, number and pattern of nails, adhesive or screws. **DO NOT** use this Hoist to store panels.
- Place Panel Hoist on correct surface. Only use this Hoist on a stable, level, clean, hard and dry surface that is capable of sustaining the load. Stabilize the load. Ensure that the load remains stable at all times. **DO NOT** move the load while it is on the Hoist.
- **DO NOT** lubricate any part of the Winch components. The brake is friction based and may fail if lubricated
- Before lifting load to full height, first lift a short distance. Check that the brake is engaged, then continue to lift to full height.
- Before each use, check that the cable is properly tensioned and wound tightly and evenly onto the spool.

PRODUCT INFORMATION

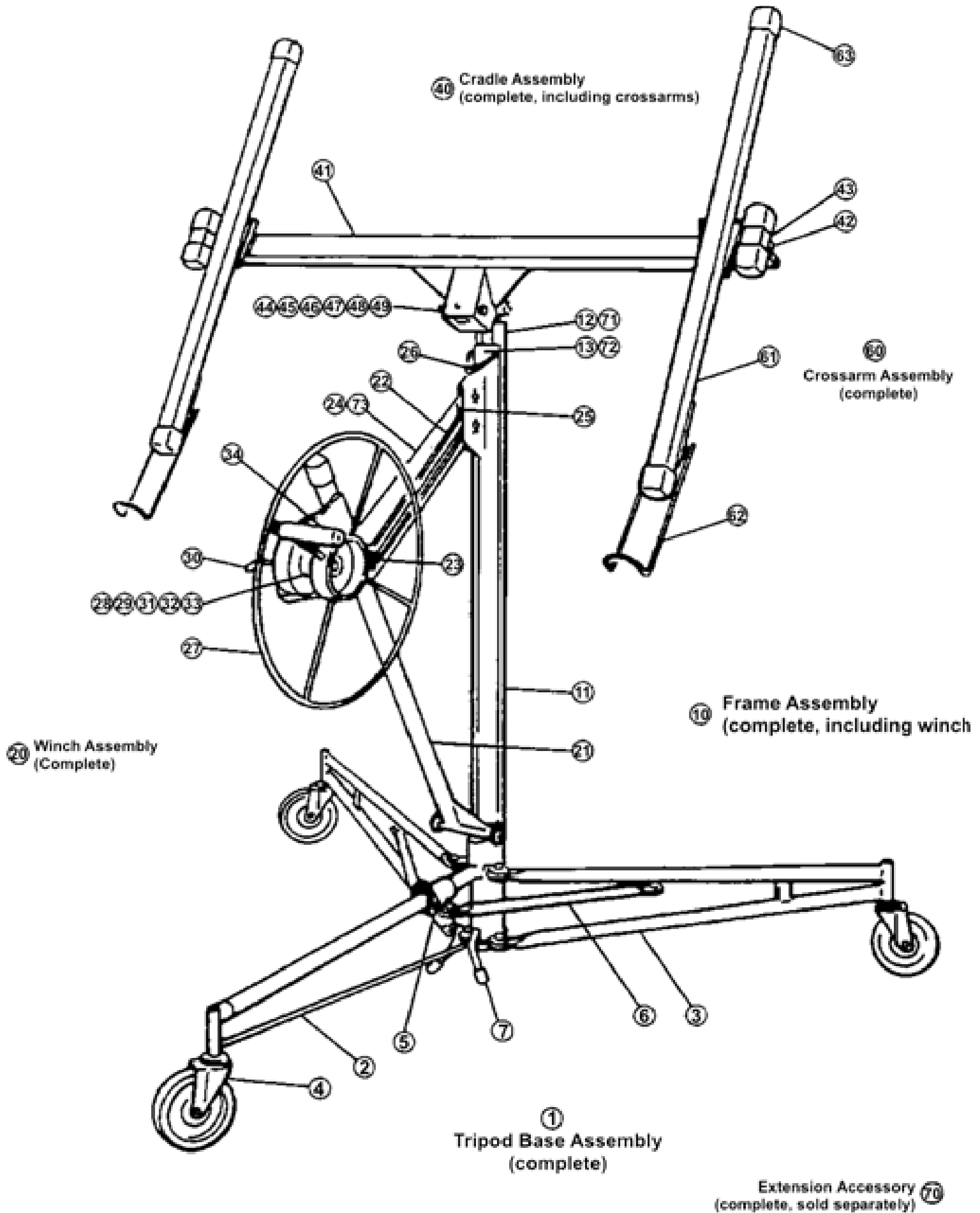

PARTS INFORMATION

Ref. No.	Description	Qty
<i>Tripod Base</i>		
1	Tripod base assembly	1
2	Center Leg (with fasteners)	1
3	Outer Leg (with fasteners)	2
4	4-in Caster	3
5	Slide Yoke Ring Tension Spring	1
6	Tie Arm (with fasteners)	2
7	Rubber Backstop Tip	2

<i>Frame Assembly</i>		
10	Frame Assembly (Includes Winch Assembly)	1
11	Frame Housing	1
12	4-ft Inner Telescoping Section	1
13	4-ft Outer Telescoping Section (with pulley)	1

<i>Winch Assembly</i>		
20	Winch Assembly	1
21	Winch Host (with pin and fastener)	1
22	Slide Bar (with axle and cotter pin)	1
23	Slide Bar Lock (with fasteners)	1
24	13½ -ft Cable*	1
25	Cable Pulley (with axle and cotter pin)	3
26	Retaining Hook	1
27	Winch Wheel (with flange bearings)	1
28	7/8-in Bushing	1
29	M12x125 Bolt (with fasteners)	1
30	Brake Arm Assembly	1
31	Brake Lining (with fasteners)	1
32	Brake Arm Tension Spring	1
33	Brake Hub (with bolts)	1
34	Winch Wheel Handle	1

*IMPORTANT: Carefully follow the instructions supplied with the replacement cable.

Ref. No.	Description	Qty
<i>Cradle Assembly</i>		
40	Cradle Assembly	1
41	Cradle Body	1
42	Outrigger Lock Pin (with spring & clip)	2
43	Outrigger (with end caps)	2
44	Cradle Mounting Lead Assembly	1
45	Mounting Head Body	1
46	Cradle Tilt Latch (with fasteners)	1
47	Tension Spring	1
48	Compression Spring	2
49	Hinge Pin (with bolts)	1

<i>Cradle Crossarms</i>		
60	<u>Crossarm</u> Assembly	2
61	<u>Crossarm</u> Body	2
62	Panel Support Lock (with fasteners)	2
63	<u>Crossarm</u> End Cap	2

<i>Extension Accessory (Sold Separately)</i>		
70	Extension Accessory	1
71	6-ft Inner Telescoping Section	1
72	6-ft Outer Telescoping Section	1
73	17½ -ft Cable*	1

ASSEMBLY

COMPONENTS:

The Drywall Lift is shipped as several components that must be assembled before use:

- Tripod base assembly.
- Frame assembly, which includes a winch assembly and standard (4-ft) telescoping lift sections
- Cradle assembly, without its detachable crossarm
- Two cradle crossarm assembly

ASSEMBLY PROCEDURE:

1. Set up the tripod base:

- A. Set the base on the floor, resting on its casters.
- B. Press down on the slide yoke ring. Hold the ring down while you swing the two forward legs out until the yoke ring snaps into the locking hole on the bottom of the slide tube. (See Figure 1)
- C. To prevent the tripod base from rolling backward during assembly, lower the backstop as shown.

2. Set the frame assembly onto the two "V" angles on the tripod base, and lower the frame about 1 in. until it is secured by the angles. Before continuing, be sure the frame is pushed all the way down and is held securely by the angles.

3. Attach the handle to the winch wheel. Tighten the nut, then back it off slightly so the handle turns freely.

4. Move the winch assembly into its working position:

A. Hold the winch wheel and brake arm as shown in Figure 2. Rotate the winch wheel forward slightly while you lift on the brake arm to release the brake.

B. Raise the brake arm all the way up. Grasp the winch post, and grip the brake arm firmly with your thumb. (Figure 3)

C. Place your right hand on top of the frame. Continue to grip the brake arm as needed to prevent cable backlash, and pull the winch assembly all the way toward you. (Figure 4)

D. When the winch is fully extended (away from the frame housing), release the brake arm and swing the retaining hook away so it no longer secures the telescoping sections inside the frame housing.

5. Press the winch assembly slightly back toward the frame. This automatically engages the slide bar lock to keep the winch fully extended. (Figure 5)

IMPORTANT: Before continuing, be sure that the slide bar lock is fully engaged that is, rotated clockwise as far as possible.

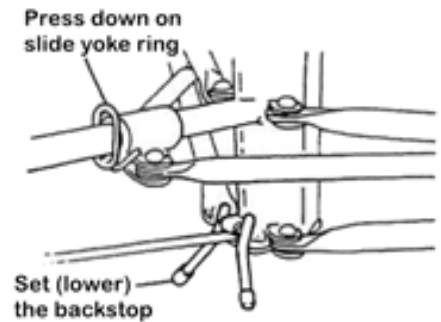
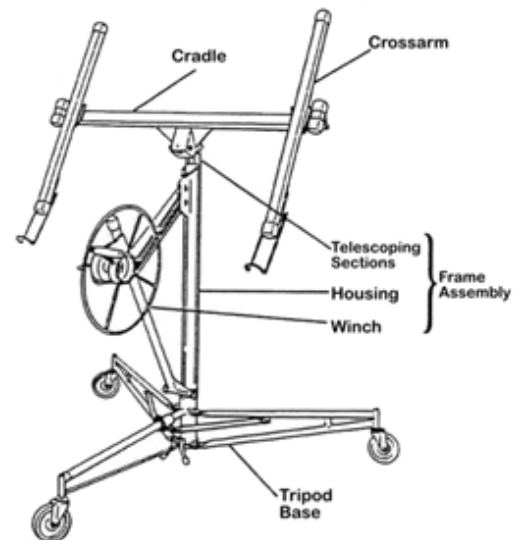

Figure 1



Components of Drywall Lift

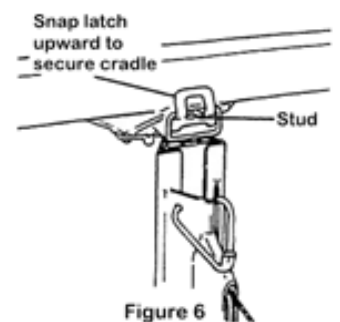

Figure 6

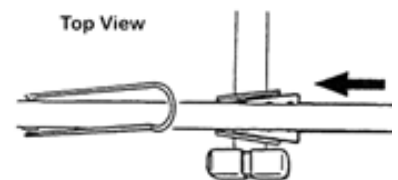

Figure 7

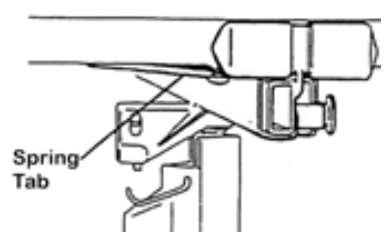
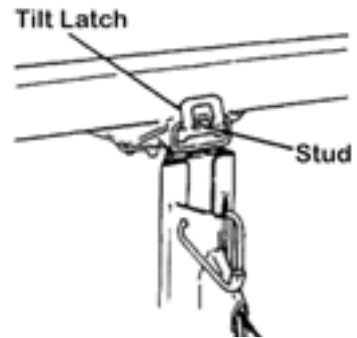

Figure 8

Tilt Latch

To allow the cradle to tilt (for loading a dry wall panel, or for raising the panel to a side wall or sloped ceiling); or to remove the cradle from the frame, pivot the tilt latch out and down. To lock the cradle onto the frame without tilting, pivot the latch up to engage the stud on the cradle.

NOTE: When it is in the level (non-tilted) position, the cradle will also tilt up to 10° side-to-side.



Brake Arm

A spring-loaded brake holds the cradle at whatever height you raise it by cranking the winch wheel. To lower the cradle, control the backward rotation of the winch by grasping the wheel handle as you carefully raise the brake arm to release the brake.

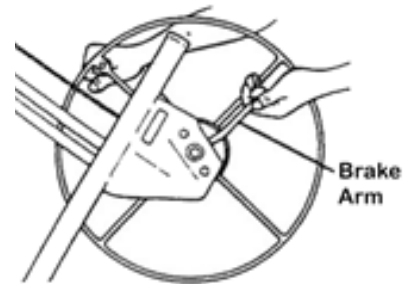

Winch Wheel, Handle, and Post

Cranking the winch (using the wheel handle) coils or uncoils the cable that raises or lowers the cradle. Grasp the post for leverage when cranking the winch.

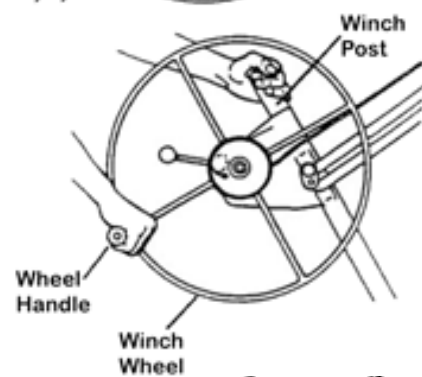

Retaining Hook

The retaining hook secures the telescoping sections inside the frame, for transport and storage.

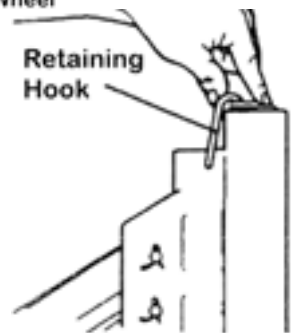

OPERATION

Extending the Cradle

IMPORTANT: Read the "Important Precautions" on page 3 before you operate the Lift.

SAFETY CHECK BEFORE OPERATION

Before you begin operating the Lift each day:

- Inspect the unit carefully for wear or damage. Pay special attention to the cable.
- Be sure the Lift is at working room temperature before operating.
- Be sure the winch brake drum is clean and dry before operating.

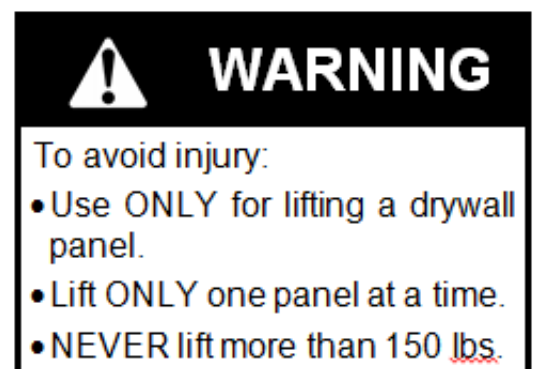
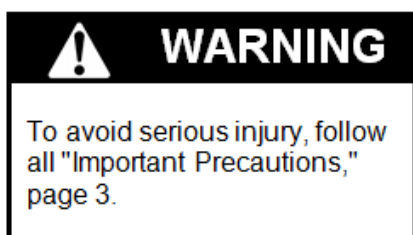

To Load a Drywall Panel

1. Set (lower) the backstop, so the Lift won't roll backward
2. Swing open the panel support hooks on the two crossarms. Be sure the cradle is turned so the support hooks are on the opposite side from the winch wheel.
3. Extend the crossarm outriggers on the cradle as needed to fully support the length of the drywall panel (see page 7).
4. Release the tilt latch to tilt the cradle (see page 8).
5. Hold the drywall panel with its face paper toward the tilted cradle, and load the panel onto the Lift as shown. Set the panel onto the support hooks, and carefully lean it against the crossarms.
6. If installing the panel on a flat ceiling, tilt the cradle back up to its level position and lock the tilt latch. If installing the panel on a side wall or a sloped ceiling, leave the cradle tilted.
7. Raise the backstop on the base, and carefully roll the Lift close to the position where the panel will be installed.

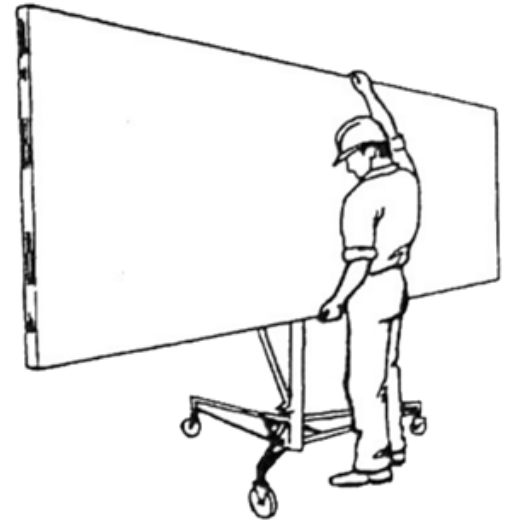

To Raise the Panel

IMPORTANT: Always lower the backstop before raising the panel to a sloped ceiling or a side wall. Crank the winch wheel in the direction shown (hold the post for leverage) until the panel is at the desired height. The brake is spring-loaded to automatically hold the cradle at the selected height when you stop cranking.

To Lower the Panel

1. Grasp the wheel handle with your right hand so you can restrain the backward rotation of the winch.
2. Retain your hold on the winch handle. Carefully release the brake with your left hand and slowly rotate the wheel backward to lower the cradle to the desired height.

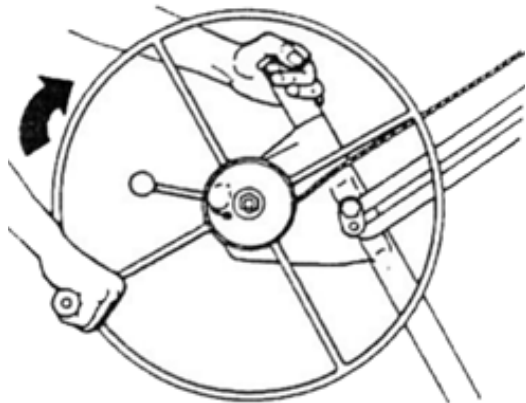

Figure 11



Figure 13

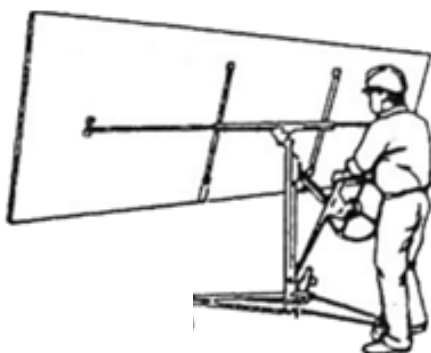
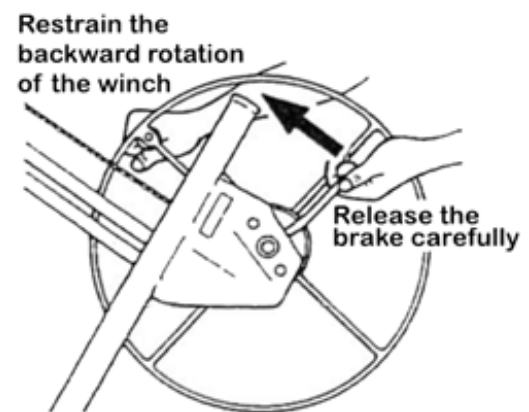

Figure 12



To Lower the Panel
Figure 14

To Load a Drywall Panel

To disassemble the Drywall Lift for transport or compact storage;

1. Crank the cradle all the way down.
2. Slide the cradle outriggers all the way in until they latch. Close the panel support hooks.
3. Remove the crossarms by pressing the spring tab on the bottom and sliding the crossarm out of the tapered socket.
4. Unlock the cradle tilt latch. Lift the cradle (about 3 in.) until you can remove it from the frame.
5. Rotate the winch wheel one full rotation forward as shown. This will raise the inner telescoping section.
6. Unlock the winch assembly by lifting the slide bar with your left hand while you rotate the slide bar lock counterclockwise with your right hand.
7. Hold the slide bar lock in this disengaged position (step 6). and press down on the telescoping sections in the frame with your left hand. The winch assembly will move toward the frame housing.
8. Crank the telescoping sections all the way down. Swing up the retaining hook as shown, and crank the telescoping sections back up slightly until secured by the hook.
9. Hold the retaining hook in this position with your left hand, and rotate the winch forward with your right hand. The winch assembly will fold up against the frame. When the slide bar contacts the frame, tighten the cable by turning the wheel further (just enough to hold the winch assembly in this position).
10. Carefully lift the frame/winch about 1 in. to free it from the tripod base.
11. To fold the base, press down on the slide yoke ring and pivot the forward legs in until they lock in the closed position.

MAINTENANCE

- Inspect the cable before each work day. Replace it at the first sign of wear (refer to the instructions supplied with the replacement cable).
- Occasionally oil the cable pulleys. Crank up the telescoping sections for access to the internal cable pulley. Never allow oil or grease to contact the surface of the winch brake drum.
- Occasionally oil the caster bearings.
- If the telescoping sections of the frame don't operate smoothly, apply household paraffin to the sliding surfaces.

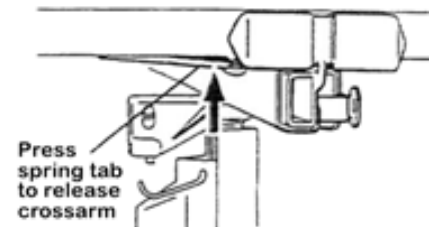

Figure 15

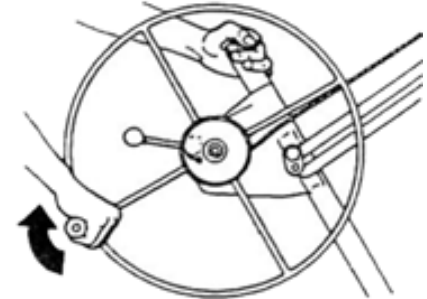

Figure 16

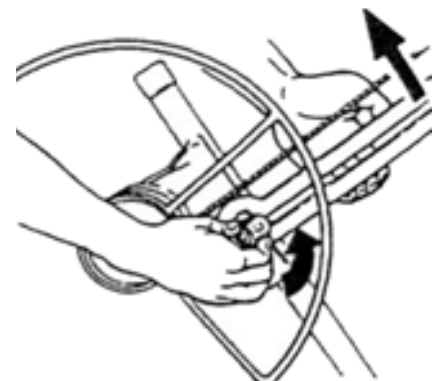

Figure 17

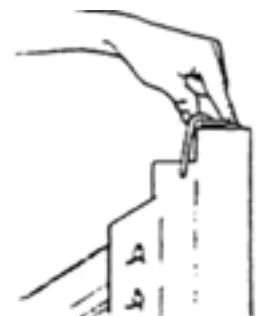

Figure 18

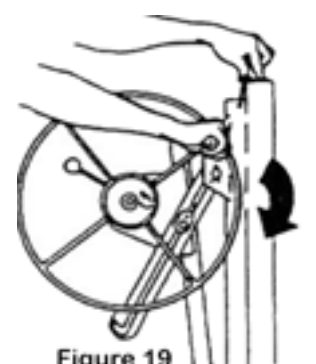

Figure 19

OPERATION

5. Place the drywall panel on the Cradle, with the outer side of the panel (the good side) facing the cradle. Carefully lean the panel on the Crossarms, being careful not to damage the edges of the panel.
6. If the panel will be installed on a flat ceiling, tilt the Cradle back to its horizontal position and lock in place with the Tilt Pin. If the panel will be installed on a side wall or sloped ceiling, leave the Cradle tilted.
7. Check to see that the panel is secure and balanced.
8. Lower the Cradle if needed, and release the Caster Locks.
9. Carefully roll the Hoist near to the position where the panel will be installed.
10. When at the appropriate location, apply the Caster Locks.

Raising the Panel

CAUTION: Lock the Locking Casters to prevent the Hoist from rolling after it is in position.

1. Crank the Winch Wheel clockwise to raise the panel slightly, then stop, checking that the Brake is functioning properly.
2. Once you have determined that the Brake is functioning properly, resume raising the panel to the desired height.
3. Raise the Telescoping Assembly so that the holes of the inner post align with the Attached Pin opening, then lock in place with the Pin Lever, or, slide the Square Pin through the Inner Pin holes above the Outer Post.

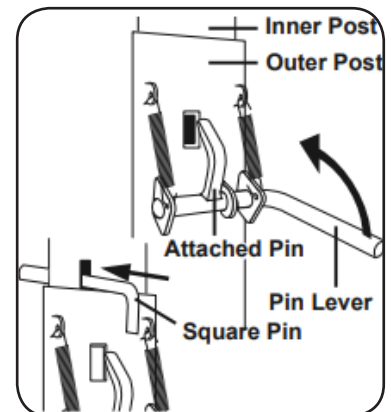
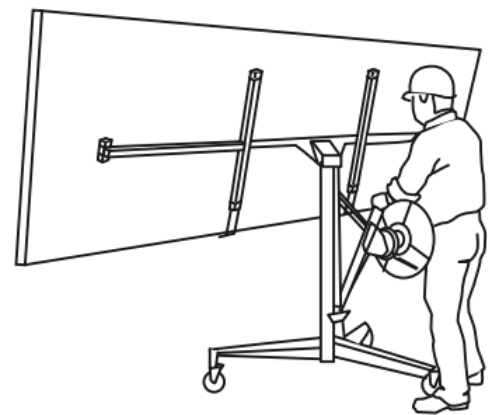

Lowering the Cradle

1. Install the drywall panel correctly before lowering Cradle.
2. Push and hold the Winch Wheel slightly forward to support the weight of the Cradle.
3. Release the Pin with the Pin Lever (see Figure S), then operate the Brake Handle with your left hand and rotate the Winch Wheel counterclockwise with your right hand to lower the Cradle.

CAUTION: DO NOT release control of the Wheel Handle as the Hoist is lowering or the Cradle may lower forcefully and cause injury.

4. After each use, lower the Cradle completely and clean all surfaces of the Hoist with a clean cloth.

DISCLAIMER

PLEASE READ THE FOLLOWING CAREFULLY

THE MANUFACTURER AND/OR DISTRIBUTOR HAS PROVIDED THE PARTS LIST AND ASSEMBLY DIAGRAM IN THIS MANUAL AS A REFERENCE TOOL ONLY. NEITHER THE MANUFACTURER OR DISTRIBUTOR MAKES ANY REPRESENTATION OR WARRANTY OF ANY KIND TO THE BUYER THAT HE OR SHE IS QUALIFIED TO MAKE ANY REPAIRS TO THE PRODUCT, OR THAT HE OR SHE IS QUALIFIED TO REPLACE ANY PARTS OF THE PRODUCT. IN FACT, THE MANUFACTURER AND/OR DISTRIBUTOR EXPRESSLY STATES THAT ALL REPAIRS AND PARTS REPLACEMENTS SHOULD BE UNDERTAKEN BY CERTIFIED AND LICENSED TECHNICIANS, AND NOT BY THE BUYER. THE BUYER ASSUMES ALL RISK AND LIABILITY ARISING OUT OF HIS OR HER REPAIRS TO THE ORIGINAL PRODUCT OR REPLACEMENT PARTS THERETO, OR ARISING OUT OF HIS OR HER INSTALLATION OF REPLACEMENT PARTS THERETO.

Record Product's Serial Number Here: _____

Note: If product has no serial number, record month and year of purchase instead.

Note: Some parts are listed and shown for illustration purposes only and are not available individually as replacement parts.



SAVE THESE INSTRUCTIONS.

The material in this manual is for informational purposes only. The product(s) it describes are subject to change without prior notice, due to the manufacturer's continuous development program. Stark Tools makes no representations or warranties with respect to this manual or with respect to the products described herein. Stark Tools shall not be liable for any damages, losses, costs or expenses, direct, indirect or incidental, consequential or special, arising out of, or related to the use of this material or the products described herein.

Questions, problems, missing parts?



Before returning to your retailer, our exceptional customer service is here to help.

Call Us: 909.628.4900

Email Us: info@starktoolsusa.com

Hours of Operation: 9am - 4pm (Monday - Friday)

PRODUCT MADE IN CHINA