



**14" X 40" 4-SPEED 1/2HP 120V WOOD TURNING LATHE**

**ITEM: 66012**



## **OWNER'S MANUAL AND SAFETY INSTRUCTIONS**

**SAVE THIS MANUAL: KEEP THIS MANUAL FOR SAFETY WARNINGS, PRECAUTIONS, ASSEMBLY, OPERATING, INSPECTION, MAINTENANCE AND CLEANING PROCEDURES. WRITE THE PRODUCT'S SERIAL NUMBER ON THE BACK OF THE MANUAL NEAR THE ASSEMBLY DIAGRAM (OR MONTH AND YEAR OF PURCHASE IF PRODUCT HAS NO NUMBER).**

**FOR QUESTIONS PLEASE CALL OUR CUSTOMER SUPPORT: (909) 628 4900 MON-FRI 9AM TO 3PM PST**

# IMPORTANT SAFETY INFORMATION



## GENERAL SAFETY WARNINGS

Read all safety warnings and instructions. Failure to follow the warnings and instructions may result in electric shock, fire and/or serious injury. Save all warnings and instructions for future reference.

## SAFETY

---

The warnings, precautions, and instructions discussed in this instruction manual cannot cover all possible conditions and situations that may occur. It must be understood by the operator that common sense and caution are factors which cannot be built into this product, but must be supplied by the operator. Read carefully and understand all **ASSEMBLY AND OPERATION INSTRUCTIONS** before operating. Failure to follow the safety rules and other basic safety precautions may result in serious personal injury.

- **Read and understand all instructions.** Failure to follow all instructions may result in serious injury or property damage.
  - **DO NOT** allow persons to operate or assemble the product until they have read this manual and have developed a thorough understanding of how it works.
  - **DO NOT modify this product in any way.** Unauthorized modification may impair the function and/or safety and could affect the life of the product. There are specific applications for which the product was designed.
  - **Use the right tool for the job.** DO NOT attempt to force small equipment to do the work of larger industrial equipment. There are certain applications for which this equipment was designed. This product will be safer and do a better job at the capacity for which it was intended. **DO NOT** use this equipment for a purpose for which it was not intended.
  - Industrial or commercial applications must follow OSHA requirements.
  - **Inspect the work area before each use.** Keep work area clean, dry, free of clutter, and well-lit. Cluttered, wet, or dark work areas can result in injury. Using the product in confined work areas may put you dangerously close to cutting tools and rotating parts.
  - **DO NOT use the product where there is a risk of causing a fire or an explosion;** e.g., in the presence of flammable liquids, gases, or dust. The product can create sparks, which may ignite the flammable liquids, gases, or dust.
  - **DO NOT allow the product to come into contact with an electrical source.** The tool is not insulated
  - **Keep children and bystanders away from the work area while operating the tool. DO NOT** allow children to handle the product.
  - **Be aware of all power lines, electrical circuits, water pipes, and other mechanical hazards in your work area.** Some of these hazards may be hidden from your view and may cause personal injury and/or property damage if contacted.
- Stay alert, watch what you are doing, and use common sense when operating the tool. **DO NOT** use the
- tool while you are tired or under the influence of drugs, alcohol, or medication.

# IMPORTANT SAFETY INFORMATION

- **Dress properly. DO NOT** wear loose clothing, dangling objects, or jewellery. Keep your hair, clothing and gloves away from moving parts. Loose clothes, jewellery, or long hair can be caught in moving parts. Air vents on the tool often cover moving parts and should be avoided.
- **Wear the proper personal protective equipment when necessary.** Use ANSI Z87.1 compliant safety goggles (not safety glasses) with side shields, or when needed, a face shield. Use a dust mask in dusty work conditions. Also use non-skid safety shoes, hard-hat, gloves, dust collection systems, and hearing protection when appropriate. This applies to all persons in the work area.
- **DO NOT overreach.** Keep proper footing and balance at all times.
- **Check for damaged parts before each use.** Carefully check that the product will operate properly and perform its intended function. Replace damaged or worn parts immediately. Never operate the product with a damaged part.
- **DO NOT use a product with a malfunctioning switch.** Any power tool that cannot be controlled with the power switch is dangerous and must be repaired by an authorized service representative before using.
- **Disconnect the power/air supply from the product and place the switch in the locked or off position before making any adjustments,** changing accessories, or storing the tool. Such preventive safety measures reduce the risk of starting the tool accidentally
- **Use only accessories that are recommended by the manufacturer for use with your product.** Accessories that may be suitable for one product may create a risk of injury when used with another tool. Never use an accessory that has a lower operating speed or operating pressure than the tool itself.
- **Keep guards in place and in working order.** Never operate the product without the guards in place.
- **DO NOT leave the tool running unattended.**
- Always wear the proper protective equipment including ANSI Z87.1 compliant eye protection, NIOSH compliant breathing protection, anti-vibration work gloves, steel toed work boots, and a helmet.
- **Remove adjusting keys and wrenches.** Form a habit of making sure keys and wrenches are removed from the tool before turning it on.
- **NEVER stand on the tool.** Serious injury can occur if the tool is tipped over or if the cutting tool is contacted.
- Maintain tools with care. Keep tools sharp and clean for better and safer performance. Follow instructions for lubricating and changing accessories.
- **DO NOT** alter or misuse the tool. These tools are precision built. Any alteration or modification not specified may result in a dangerous condition.
- Avoid gaseous areas. Do not operate electric tools in an explosive or gaseous atmosphere. The motor in this tool normally spark and could react creating a dangerous situation.

**WARNING:** Before connecting the tool to a power source be sure the voltage supplied is the same as that specified on the nameplate of the tool. A power source with a voltage greater than that specified for the tool can result in serious injury and could damage the tool. If in doubt, **DO NOT PLUG THE TOOL IN.** Using a power source with a voltage less than the nameplate rating is harmful to the motor.

# DIAGRAM AND SPECIFICATIONS

## MOTOR SPECIFICATIONS

The Wood Lathe is designed to use a 3400 RPM motor only. Do not use a motor that runs faster than 3400 RPM. This Wood Lathe is wired for operation on 110-120 volts, 60Hz alternating current.

**WARNING** To avoid injury from unexpected start-up, do not use blower or washing machine motors or any motor with an automatic reset overload protector.

## CONNECTING TO A POWER SOURCE

This machine must be grounded while in use to protect the operator from electric shock. Plug the power cord into a 110-120V grounded type outlet protected by a 15-amp dual element time delay fuse or circuit breaker.

Not all outlets are properly grounded. If you are unsure if your outlet is properly grounded, have it checked by a qualified technician prior to using this tool.

**WARNING** Failure to properly ground this tool can cause electrocution. If shocked, your reaction could cause your hands to hit the cutting tool.

**WARNING** If the power cord is damaged in any way, have it replaced immediately to avoid shock, injury or fire hazard.

## MOTOR SPECIFICATIONS AND ELECTRICAL REQUIREMENTS

This Wood Lathe tool is equipped with a 3-conductor cord and grounding plug. The ground conductor has a green jacket and is attached to the tool housing at one end and to the ground prong in the attachment plug on the other end. This plug requires a mating 3-conductor as pictured below. If the outlet you are planning to use for this power tool is of the 2-prong type, **DO NOT REMOVE OR ALTER THE GROUNDING PRONG IN ANY MANNER**. Use an adapter as shown and always connect the grounding plug to known ground. It is recommended that you have a qualified electrician replace the 2-prong outlet with a properly grounded 3-prong outlet.

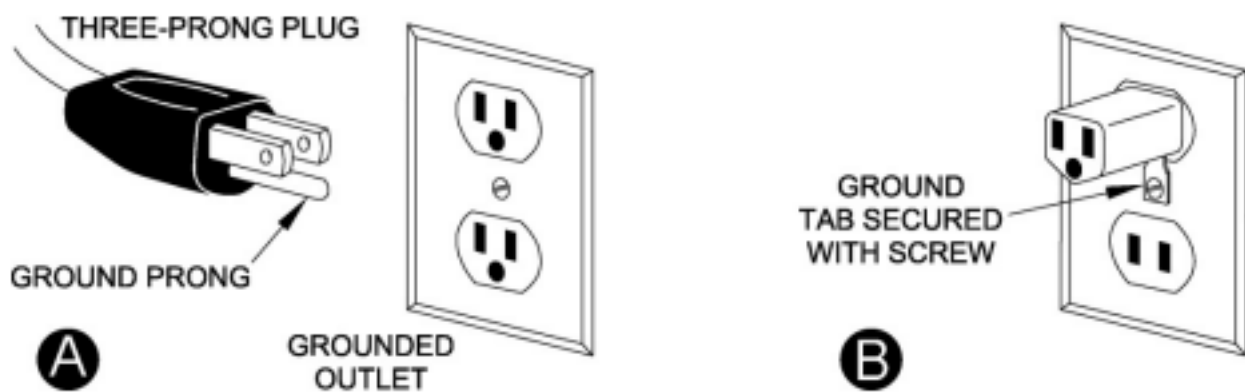

**WARNING** The green grounding plug extending from the adapter must be connected to a permanent ground such as a properly grounded outlet box.

# DIAGRAM AND SPECIFICATIONS

The use of any extension cord will cause some loss of power. To keep this to a minimum and to prevent overheating and motor burn out, use the table to determine the minimum wire size (A.W.G.) for an extension cord. Use one a 3-wire extension cord which have 3-prong grounding type plugs and 3-pole receptacles which accept the tool's plug.

EXTENSION CORD LENGTH	WIRE SIZE A.W.G.
0-25 FEET	16
26-50 FEET	14
51-100 FEET	12

## PARTS IDENTIFICATION

**ON/OFF SWITCH:** Device to turn the Wood Lathe power ON or OFF.



**BELT AND PULLEY COVER:** Cover for the Belt and Pulley. Open this cover when changing the speed of the drive center.

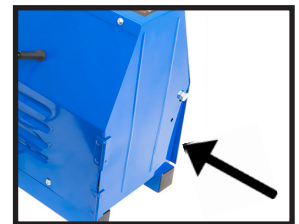

**DRIVE CENTER:** Holds the work piece for turning jobs.

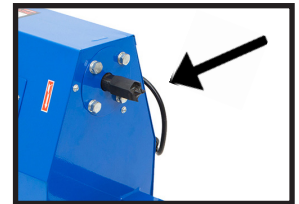

**BED RAILS:** Rails fir moving tail stock and tool rest.

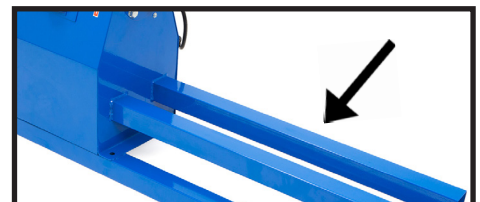

**TOOL REST:** Holds the tool then turning the work piece.



**TOOL REST LOCK KNOB:** Lock knob for heigh adjustment of the tool rest.



**TAIL STOCK ASSEMBLY:** Works with the drive center to hold the work piece for turning jobs.

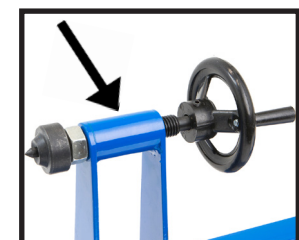



# OPERATION AND ADJUSTMENTS

**Separating and checking contents:** Separate all loose parts from packing materials and make sure all parts are accounted for before discarding packing material. If any parts are missing, do not attempt to assemble the Wood Lathe or plug into a power source. If pieces are missing, contact your distributor or XtremePowerUS directly.

To avoid fire or toxic reaction, never use gasoline, naphtha or any highly volatile solvents.

Apply a coat of paste wax to the table and base to prevent rust. Wipe all parts thoroughly with a clean dry cloth.

## CONTENTS ON BOX:



**BODY ASSEMBLY**



**FACEPLATE**



**HEX WRENCH**

**THIS MACHINE HAS BEEN ASSEMBLED AND TESTED AT THE FACTORY.**

**ADJUSTING BELT TENSION:** The Lathe comes with the belt pre-installed. However, it will need an adjustment prior to use.

Disconnect the Lathe from power source. Loosen and remove the hex bolt with the adjustable wrench. Press down on the belt with your hand, the belt should move 1/2" when set properly.

**ADJUSTING SPEED:** Four spindle speeds of 1100, 1600, 2300 and 3400 RPM are available with the lathe. **Chart 1** shows which step of the pulleys the belt must be placed to obtain four speed. **Chart 2** shows the proper speeds for the work piece.

ROUGHING OFF	GENERAL CUTTING	FINE CUTTING	FINISHING
1100 RPM	1600 RPM	2300 RPM	3400 RPM

**CHART 2**

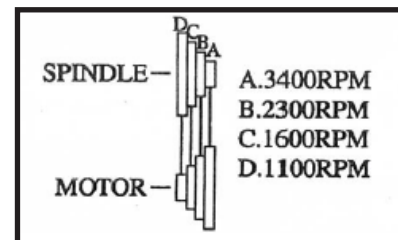

**CHART 1**

1. Disconnect the lathe from power source.
2. Open the belt and pulley cover.
3. Loosen the motor pulley by loosening the bolts with adjustable wrench.
4. Place the "V" belt to correct position for desired speed.
5. Adjust "V" belt to proper tension and tighten the motor pulley.

**NOTE:** For proper belt tension, press down on the belt with your hand. The belt should move 1/2" when set properly.

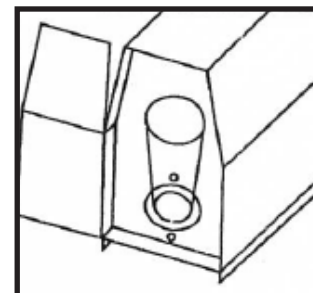

# OPERATION AND ADJUSTMENTS

## MOVING TAIL STOCK ASSEMBLY AND TOOL REST

The tail stock assembly and tool rest are held to the bed with the lock handle right underneath the bed rails. To move them to a new position:

1. Disconnect the lathe from power source.
2. Loosen the lock handle with the knob.
3. Slide the tail stock assembly or tool rest along the bed and re-tighten the lock handle.

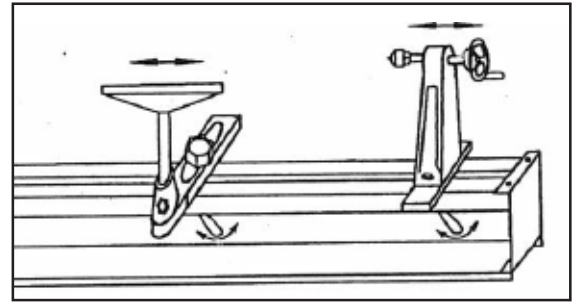

## MOUNTING THE LATHE

The lathe must be mounted to a firm supporting surface such as a stand or workbench when operating. To mount lathe:

1. Disconnect the lathe from power source.
2. Locate and mark where the lathe is to be mounted.
3. Drill four 5/16" diameter holes through the workbench.
4. Place the lathe on the workbench, aligning holes in the bed with holes drilled into the workbench.
5. Insert four bolts (sold separately) and tighten.

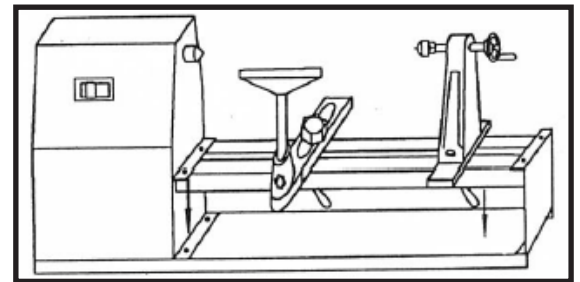

## REMOVING TAIL STOCK SPINDLE

To remove the tail stock spindle from the tail stock assembly:

1. Disconnect the lathe from power source.
2. Remove the hand wheel by loosening the set screw with 1/8" hex wrench away from the spindle. See Fig. 1
3. Unscrew tail stock spindle from the tail stock assembly. See Fig. 2

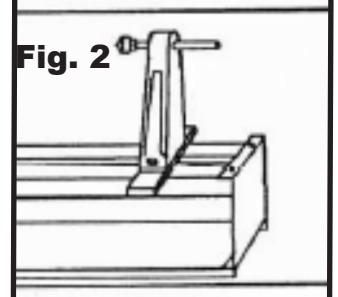
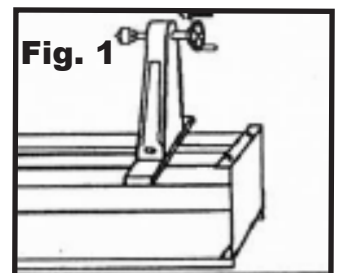

## REMOVING DRIVE CENTER

The Drive Stock center must be removed to attach to the stock when the spindle is turning. It also needs to be removed when attaching the faceplate for turning the faceplate. To remove the drive center from driving spindle.

1. Disconnect the lathe from power source.
2. Using a wrench, hold the flat neck of the driving spindle, then unscrew the drive center counter-clockwise.

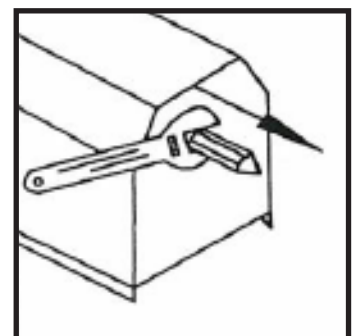

# OPERATION AND ADJUSTMENTS

## INSTALLING THE FACEPLATE

The faceplate is supplied with your lathe. To install the faceplate:

1. Disconnect the lathe from power source.
2. Remove the drive center from the driving spindle.
3. Align the center hole of faceplate to the thread of the spindle.
4. Screw the faceplate into the spindle.

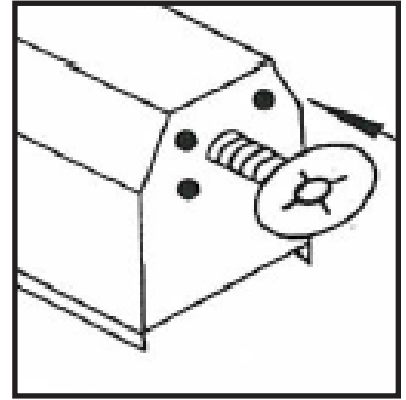

## ALIGNING CENTERS

If the centers are not in the lines, make the following adjustments:

1. Move the tail stock assembly close to the drive center assembly.
2. Lock the tail stock assembly.
3. Loosen the four hex bolts around the drive center.
4. Swing the drive center so that the two centers are in line, then tighten the bolts.

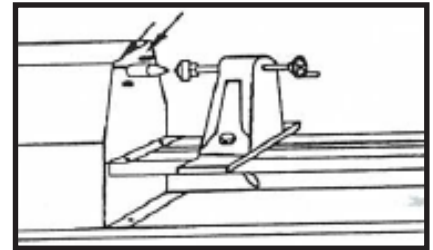
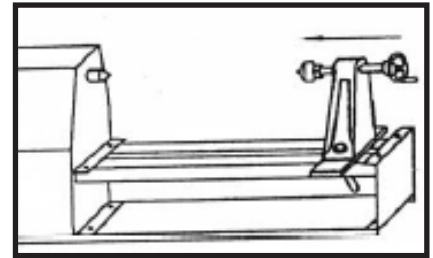

## OPERATION BASICS

---

### HAND POSITIONING

The position of your hand on the tool will determine the amount of leverage required. The tool rest general position is a palm up grip. The first finger acts as a guide, sliding along the tool rest as the cut is made. The palm down grip can be utilized for heavy roughing applications. The heel of the hand or the little finger will serve as a guide.

### ROUGHING A SPINDLE CYLINDER

The large gouge is used for turning operation. Run the lathe at low speed for this operation. The cut should start about 2" from the end of the tail stock and will continue back towards the tail stock end. Each corresponding cut will take place about 3" from the head stock center. You can then roll the gouge in the opposite direction, which will carry the cut to the end of the spindle.

### THE PARTING TOOL

This is used to cut directly into the material, or to make a cut off. Also used for scraping and to set diameters. It is a narrow tool at 1/8" wide and is shaped to cut its own clearance so the edge won't be burned. When used for scraping, it should be backed off regularly to prevent overheating. Unlike the gouge and skew, the parting tool is seldom held with the bevel against the work. As the amount of stock removed is small, a support for the bevel is not necessary. The tool is simply fed into the work at an angle (for cutting), or pointed at the work piece center (for scraping).



# OPERATION AND ADJUSTMENTS

## USING A SKEW

The tool is nearly always used to make finished cuts, to cut vees and beads and to square shoulders. It produces the best finish that can be obtained without a chisel. To avoid dulling, it should be used very little for scraping. For finish cutting, the skew is held with the cutting edge considerably in advance of the handle, bevel side down. Keeping the skew well over the work, pull it back until the edge begins to cut, then swing the handle into position to advance the cut. Both the toe and heel of the skew can be used for taking light cuts. To avoid burning the tip of the tool, do not penetrate the wood too deeply without cutting clearances.

## CUTTING A SHOULDER

A shoulder can be the side of a square portion left in the work piece, the side of a turned section, or the end of the work piece. Most shoulders are perpendicular to the work axis but a shoulder can be at any angle.

First, mark the position of the shoulder with a pencil held to the revolving work piece. Then make sizing cut via the parting tool, placing the cut about 1/16" outside the shoulder position. Cut to within 1/8" of the depth desired for the area outside the shoulder position. Cut to within 1/8" of the depth desired for the area outside the shoulder. If the shoulder is shallow, the toe of the skew can be used to make a sizing cut. Do not go in than 1/8" with the skew unless wider vees are cut to provide clearance for the tool.

Use the gouge to remove any waste stock outside of the shoulder. Smooth the section up to within 1/8" of the shoulder unless it is more than 1" high, it is best done with the 1/2" skew. First, use the toe of the skew to remove the shavings from the side of the shoulder down to the finished size. Hold the skew so the bottom edge of the bevel next to the shoulder will be nearly parallel to the side of the shoulder. Make sure this is with the cutting edge turned away at the top so that only the extreme toe will do the cutting. If the cutting edge is flat against the shoulder the chisel will run. Start with the handle low and then raise it to advance the toe into the work. Cut down to finished diameter of the outside area, then clean out the corner by advancing the heel of the skew into along the surface the outside area. Tilt the cutting edge with the handle raised up so that only the extreme heel does the cutting if the shoulder is at the end of the work called "squaring the end". In this case, reduce the outer portion to a diameter about 1/4" larger than the tool center diameter, saw off the waste stock later.

## CUTTING COVES

Use a pencil mark to indicate edges, then rough it out to within about 1/8" of the desired finish surface by scraping with the gouge or round nose chisel. If the cove is too wide, sizing cuts can be made to plot the roughing out. Once it is roughed out, the cove can be finished in two cuts; one from each side to the bottom center.

At the start of either cut, gouge is held with the handle high and the two sides of the blade held between the thumb and forefinger of the tool rest handle, just above the bevel. Position the fingers ready to roll the blade into the cove. Hold the blade so that the bevel is at a 90 degree angle to the work axis, with the point touching the pencil line and pointed into work axis.

From this start, depress the point slightly to start the cut, then continue to move the point down in an arc toward the bottom center cove. At the same time, roll the chisel uniformly so that at the end of the cut, it will be flat at the bottom of the cove. The object is to keep the extreme point of the gouge doing the cutting from start to finish. Reverse movements to cut the opposite side.

# OPERATION AND ADJUSTMENTS

## CUTTING VEES

Vee grooves can be cut with the toe or heel of the skew. When the toe is used, the cutting action is exactly the same as the same as in trimming a shoulder, except the skew is tilted to cut at the required bevel. Light cuts should be taken down on one side first, then the other, gradually enlarging the vee to the required depth and width.

When the heel is used, the skew is rotated down into the work using the tool rest as a pivot. Otherwise, the cutting position and sequence of cuts is the same. As when using the toe, it is important that cutting be done only by the extreme end of the cutting edge. If deep vees are planned, it is easier to start them by making a sizing cut at the center of each vee. Vees can also be scraped with a spear point chisel or three-sided file.

## LAYING OUT YOUR PROJECT

Make a layout first to provide a visual pattern to follow while working the turning. The pattern can be laid out in the same manner as spindle patterns. Templates can be held against the work for visual comparison. Circles to locate the various critical points can be quickly scribed on the rotating work by using the dividers.

## TURNING THE PROJECT

The first step is to remove as much wood as possible by boring into the center with the largest wood bit available. Be careful to measure in advance the depth to which the drill can be allowed to go.

Next, remove the bulk of the waste by scraping with the round-nose scraper or the bowl gouge. Remove up to within 1/8" of the finished size in this manner. Finish off the inside the circumference by scraping with the round nose or left round scraper. Smooth the bottom of the recess by scraping it with a flat nose scraper. Always try to position the part of the tool rest that supports the tool as close to the working surface as possible.

## MOUNTING THE WORK PIECE TO THE FACEPLATE

You can directly mount the faceplate to the work piece by fastening four (or eight) wood screws (sold separately) to the work piece.

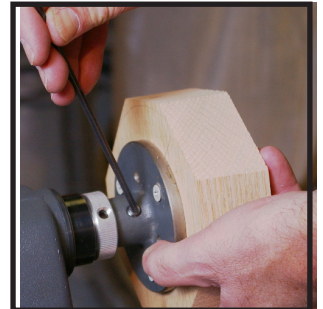

Always make sure the work piece is securely fastened to the faceplate or between centers. When the faceplate is turning, always make sure the screw fasteners do not come in contact with the turning tool as work progresses.

## FACEPLATE TURNING

Turning that does not mount between centers require a faceplate for holding the work piece. All work pieces of this type should be slightly oversized to eliminate roughing cuts and vibration.

# TROUBLESHOOTING

Symptom	Possible Cause	Correction
Excessive vibration.	Workpiece warped, out of round, has major flaw, or was improperly prepared for turning.	Correct problem by planing, bandsawing, or scrap the workpiece altogether.
	Worn spindle bearings.	Replace bearings.
	Worn belt.	Replace belt.
	Motor mount bolt or handle loose.	Tighten bolt or handle.
	Lathe on uneven surface.	Shim lathe bed, or adjust feet on stand.
Motor or spindle stalls or will not start	Excessive cut.	Reduce cut depth.
	Worn motor.	Replace motor.
	Broken belt.	Replace belt.
	Worn spindle bearings.	Replace bearings.
	Improper cooling on motor.	Clean sawdust from motor fan.
Motor fails to develop full power.	Power line overloaded.	Correct overload condition.
	Undersize wires in supply system.	Increase supply wire size.
	Low voltage.	Request voltage check from power company and correct low voltage condition.
	Worn motor.	Replace motor.
Tools tend to grab or dig in.	Dull tools.	Sharpen tools.
	Tool support set too low.	Reposition tool support height.
	Tool support set too far from workpiece.	Reposition tool support closer to workpiece.
	Improper tool being used.	Use correct tool for operation.
Tailstock moves when applying pressure	Excessive pressure being applied by tailstock. Note: The screw action of the tailstock is capable of applying excessive pressure to workpiece and headstock. Apply only sufficient force by tailstock to hold workpiece securely in place. Excessive pressure can cause damage to machine.	Slide tailstock down to the right side of the lathe against the stop. Move headstock into position and apply pressure to workpiece with tailstock.
	Lathe bed and tailstock mating surfaces are greasy or oily.	Remove and clean surfaces with a cleaner degreaser.
Digital readout does not work	Digital readout sensor out of position.	Open the belt access and position the sensor so that it reads the bolts.

# PARTS LIST

## MAINTAINING YOUR WOOD LATHE



For your own safety, turn the power off and remove the plug from the power source outlet before maintaining or lubricating your wood lathe. Blow out any dust that may accumulate inside the motor. A coat of automobile-type wax applied to the rail and center driver will help to keep the surfaces clean. If the power cord is cut, worn or damaged, do not plug it in and have it repaired or replaced to avoid shock, a fire hazard or serious injuries.

All repairs, electrical or mechanical, should be performed by a trained professional only.

### LUBRICATION

All of the ball bearings are packed with grease at the factory, they require no additional lubrication. Periodically lubricate the center driver and tailstock assembly.

### PARTS LIST

No.	Description	Qty	No.	Description	Qty
1	Handle sleeve	2	33-1	Motor pulley	1
2	Operating handle	2	34	Screw	2
3	Press plate	2	35	Fixing plate	1
4	Bolt	2	36	Cable bush	1
5	Hand wheel	1	37	Cap nut	2
6	Screw	3	38	Microswitch plate	1
7	Threaded rod	1	39	Screw	2
8	Tail stock	1	40	Microswitch	1
9	Nut	1	41	Cable for microswitch	1
10	Ball bearing	1	42	Box for microswitch	1
11	Tail stock spindle	1	43	Nut	1
12	Knob	1	44	Flat washer	2
13	Tool rest	1	45	Press paw for microswitch	1
16	Tool rest support	1	46	Screw	2
17	Bolt	8	47	Lock nut	1
18	Elastic washer	20	48	Bolt	1
19	Flat washer	31	49	Rubber sleeve	1
20	Drive centre	1	50	Cable & plug	1
21	Ball bearing plate	1	51	Steel cover	1
22	Ball bearing	1	52	Bolt	4
23	Ball bearing support (A)	1	53	Motor	1
24	Spindle	1	54	Nut	20
25	Magnetic switch	1	55	Lathe bed	1
26	Flat washer	6	56	Screw	2
27	Screw	4	57	Elastic washer	3
28	Head stock	1	58	Earth wire	
29	Ball bearing support (B)	1	59	Teeth washer	3
30	Bolt	2	60	Steel plate	1
31	Ball bearing	1	61	Nut	1
32	V-belt	1	62	Flat washer	2
33	Spindle pulley	1			

# PARTS DIAGRAM

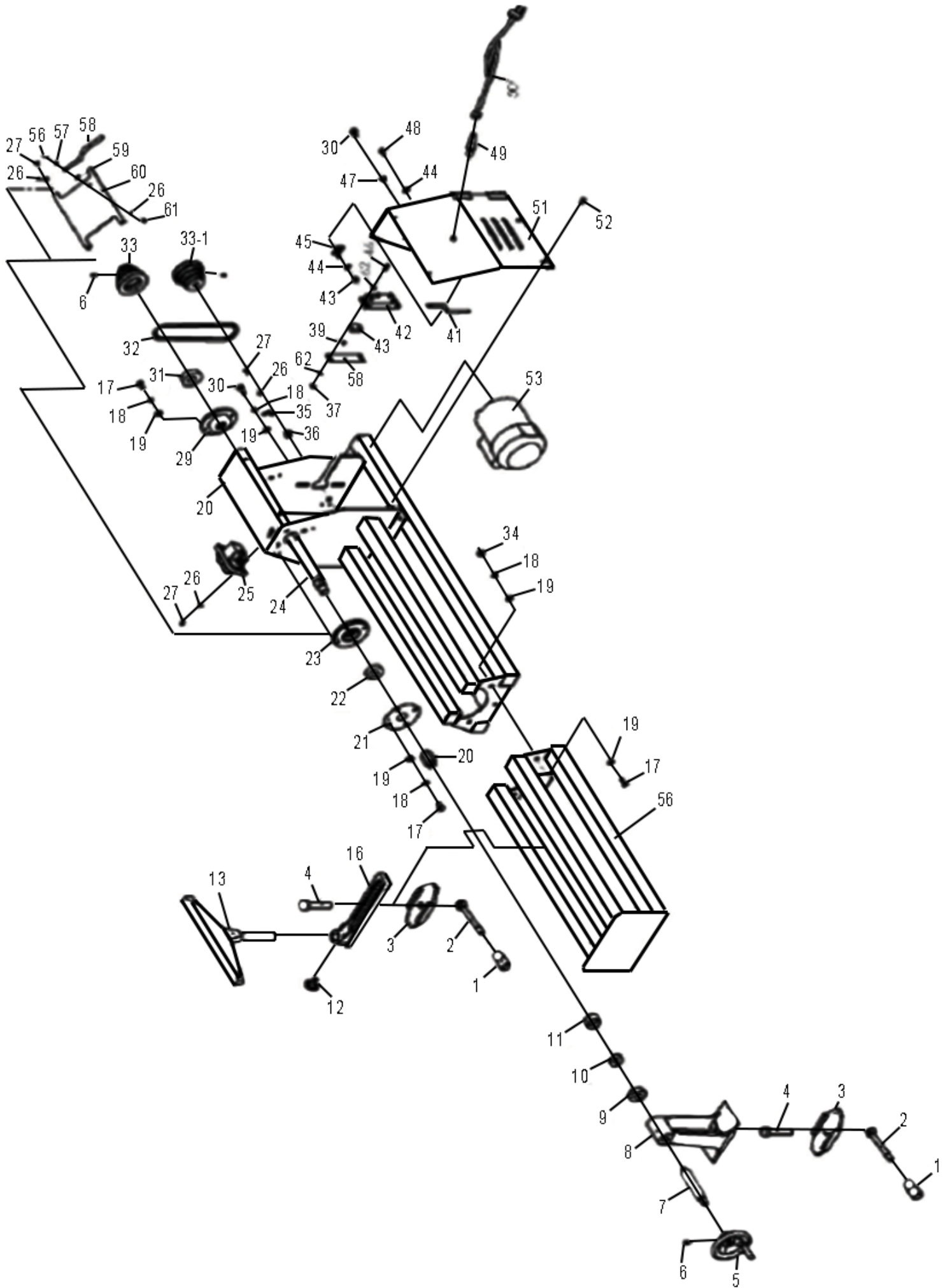



# DISCLAIMER

## PLEASE READ THE FOLLOWING CAREFULLY

THE MANUFACTURER AND/OR DISTRIBUTOR HAS PROVIDED THE PARTS LIST AND ASSEMBLY DIAGRAM IN THIS MANUAL AS A REFERENCE TOOL ONLY. NEITHER THE MANUFACTURER OR DISTRIBUTOR MAKES ANY REPRESENTATION OR WARRANTY OF ANY KIND TO THE BUYER THAT HE OR SHE IS QUALIFIED TO MAKE ANY REPAIRS TO THE PRODUCT, OR THAT HE OR SHE IS QUALIFIED TO REPLACE ANY PARTS OF THE PRODUCT. IN FACT, THE MANUFACTURER AND/OR DISTRIBUTOR EXPRESSLY STATES THAT ALL REPAIRS AND PARTS REPLACEMENTS SHOULD BE UNDERTAKEN BY CERTIFIED AND LICENSED TECHNICIANS, AND NOT BY THE BUYER. THE BUYER ASSUMES ALL RISK AND LIABILITY ARISING OUT OF HIS OR HER REPAIRS TO THE ORIGINAL PRODUCT OR REPLACEMENT PARTS THERETO, OR ARISING OUT OF HIS OR HER INSTALLATION OF REPLACEMENT PARTS THERETO.

**Record Product's Serial Number Here:** \_\_\_\_\_

**Note:** If product has no serial number, record month and year of purchase instead.

**Note:** Some parts are listed and shown for illustration purposes only and are not available individually as replacement parts.



**SAVE THESE INSTRUCTIONS.**

The material in this manual is for informational purposes only. The product(s) it describes are subject to change without prior notice, due to the manufacturer's continuous development program. Stark Tools makes no representations or warranties with respect to this manual or with respect to the products described herein. Stark Tools shall not be liable for any damages, losses, costs or expenses, direct, indirect or incidental, consequential or special, arising out of, or related to the use of this material or the products described herein.

### Questions, issues or missing parts?

Before returning to your retailer, our customer service team is here to help.



Call Us: 909.628.4900

Email Us: [info@starktoolsusa.com](mailto:info@starktoolsusa.com)

Hours of Operation: 9am - 3pm PST Monday - Friday

**PRODUCT MADE IN CHINA**