



SWIMMING POOL HEAT PUMP

ITEM# 75217



OWNER'S MANUAL AND SAFETY INSTRUCTIONS

SAVE THIS MANUAL. KEEP THIS MANUAL FOR SAFETY WARNINGS, PRECAUTIONS, ASSEMBLY, OPERATION, INSPECTION, MAINTENANCE AND CLEANING PROCEDURES. WRITE THE PRODUCT'S SERIAL NUMBER ON THE BACK OF THE MANUAL, OR THE MONTH AND YEAR OF PURCHASE IF PRODUCT HAS NO SERIAL NUMBER

FOR QUESTIONS, PLEASE CALL CUSTOMER SERVICE: 909.628.0880

SAFETY INFORMATION

WARNING

Read all safety warnings and instructions. Failure to follow the warnings and instructions may result in injury and/or property damage. Save all warnings and instructions for future reference.

The warnings, precautions, and instructions discussed in this instruction manual cannot cover all possible conditions and situations that may occur. It must be understood by the operator that common sense and caution are factors which cannot be built into this product, but must be supplied by the operator.

- The Swimming Pool Heat Pump Unit is intended to heat the swimming pool water and regulate the temperature. Use in any other application will void the warranty.
- The inlet & outlet connections cannot support any load from another piping system.
- Make certain the air outlet is not directed towards any person, animal, or vegetation.
- The unit must always be powered off before opening the access panel. Always turn off circuit supplying power to the unit prior to removing the access panel or performing any electrical work on the unit.
- All electrical connections must be performed by a qualified electrician and according to national and local electrical codes. We have provided important safety messages in this manual and on your heat pump. Always read and obey all safety messages.
- You will need to set the water temperature you desire.
- Always install the machine outdoors, while adhering to the minimal clearances needed for proper operation and heating. DO NOT place the unit next to shrubs, fences, etc. which can block the air inlet. These locations deny the unit a continuous source of fresh air which reduces its efficiency and may prevent adequate heat delivery.
- Heat Pumps must be installed in accordance with all applicable National and Local codes. In the absence of local codes, refer to the latest edition of the Canadian Electrical Code (CEC).
- The unit will automatically start up when there is proper flow and available power.
- If the unit is stopped for an extended period of time or winterized, it must be drained of all water. You will need to disconnect the IN and OUT water connections. Then the unit must then be tilted or blown out with air until all water is out.
- Do not insert any objects into the air outlet. Do not attempt to disassemble the fan at any time.
- If at any time there is any abnormal noise, odor, smoke, electricity leakage, please switch off power immediately and contact your local dealer. All repairs must be performed by a qualified technician.
- Do not store combustible or flammable material near unit.

Power Supply	208/230V ~ 60Hz
Heating Restored Power (BTU H/r)	65000
COP	6
Heating nominal Intensity	19
Ideal for pools up to (with cover)	24,000 gallons
Noise Level (dBA)	<57
Refrigerant Gas	R410a
Rate of Average Filling of Gas	4 lbs
Unit Net Weight	161lbs
Dimensions	40"x14"x29"

Note: There may be variations in values due to climatic conditions.

INSTALLATION INFORMATION

Diagram for Water Piping Connections

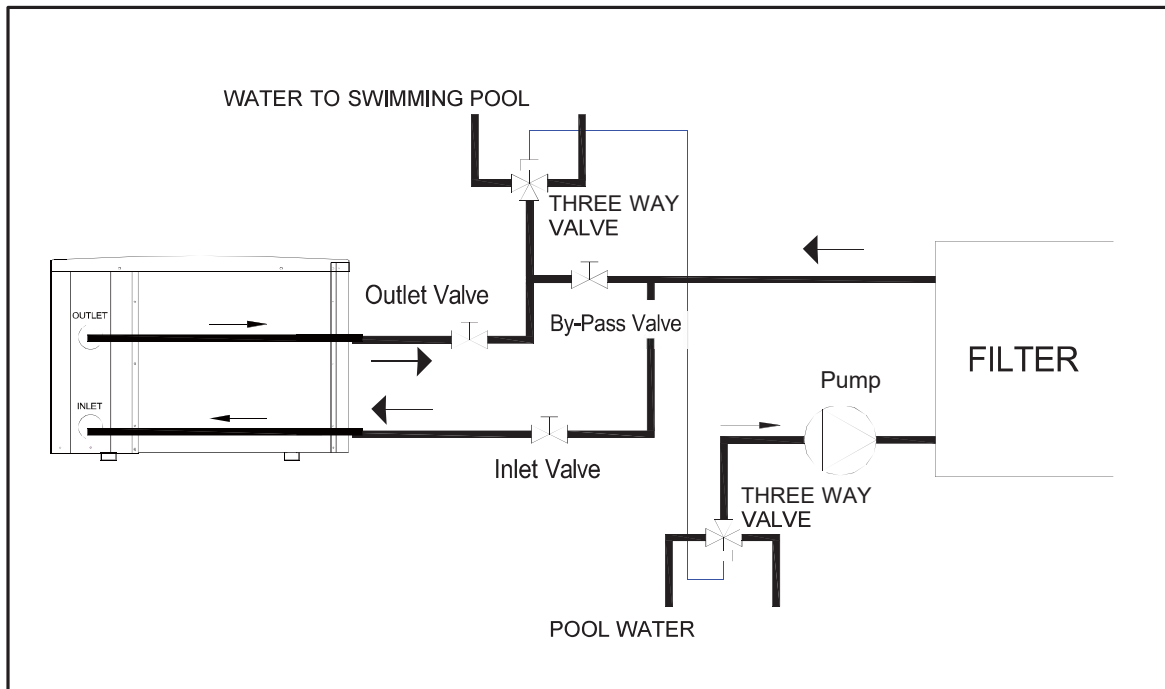

Note: The diagram is for demonstration purposes only, and layout of the pipes is for reference only.

Electric Wiring Diagram

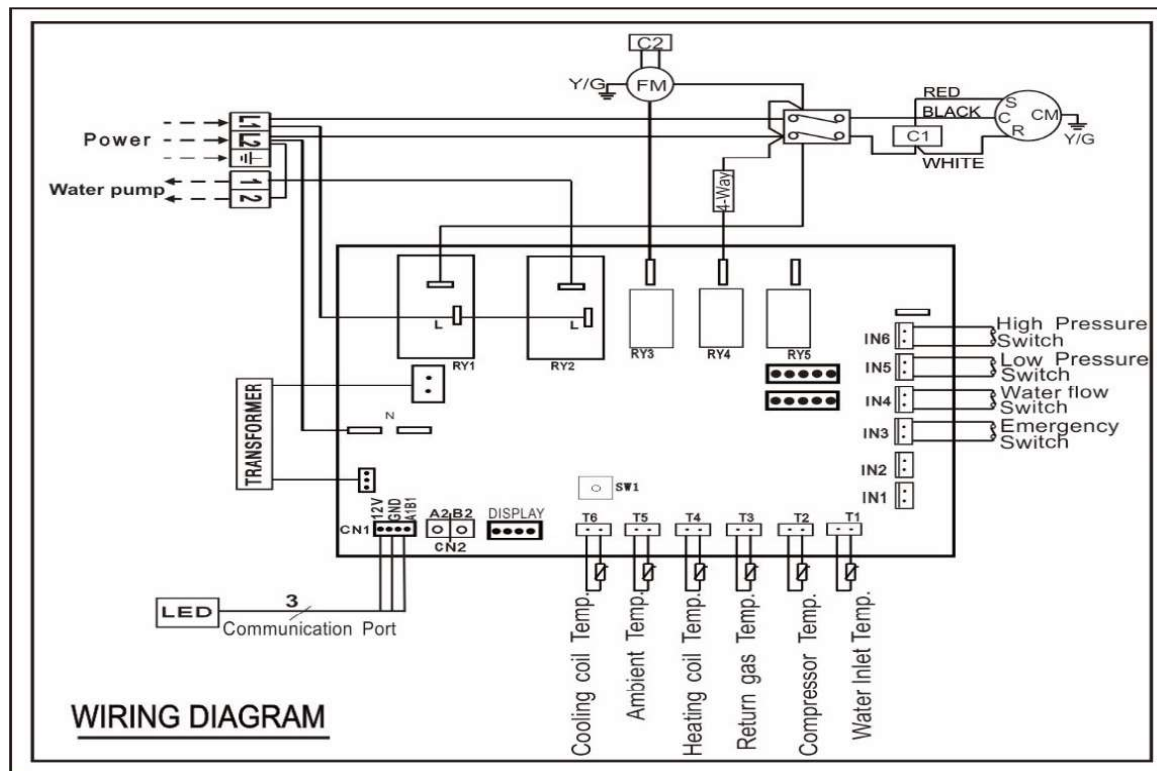

Note: The swimming pool heat pump must be grounded.

INSTALLATION INFORMATION

Protecting devices and cable specification

Breaker Rated Current : 20 A

Breaker Rated Residual Action Current : 30 mA

Fuse : 25 A

Power Cord (AWG) : 3X12

Signal Cable (AWG) : 3X20

Note: The National Electrical Code (NEC) recommends using 10-gauge copper wire for any circuit that requires a maximum of 30 Amps, regardless of voltage.

Pump protecting device cable specification is subject to user's option

Installation Instruction and Requirements:

All electrical connections must be performed by a qualified electrician and according to national and local electrical codes. We have provided important safety messages in this manual and on your heat pump. Always read and obey all safety warnings. Heat Pumps must be installed in accordance with all applicable National and Local codes. In the absence of local codes, refer to the latest edition of the Canadian Electrical Code (CEC).

Installation

1. Always install the machine outdoors, while respecting the minimal clearances needed for proper operation and heating. DO NOT place the unit next to shrubs, fences, etc. which can block the air inlet. These locations impede the unit a continuous source of fresh air which reduces its efficiency and may prevent adequate heat delivery.
2. Mount the unit on a sturdy and level base, preferably a concrete slab. The base should be completely isolated from the building foundation wall to prevent the possibility of sound or vibration transmission into the building.
3. The pool heat pump is designed for outdoor installation only and should not be installed in a fully enclosed area, such as a shed, garage, etc. Recirculation of cold discharged air back into the evaporator coil will greatly reduce unit heating capacity and efficiency. Air is pulled through the evaporator coil and discharged through the side grille. A minimum clearance of 98 inches should be allowed on the air outlet side for unrestricted air discharge. The unit must not be installed under a porch. Any other side of the unit should be located at least 28 inches from a wall or from any other obstruction for unrestricted air intake and service access.



Scan the QR Code to watch the installation video.

INSTALLATION INFORMATION

4. The piping sequence is as follows: pool > pool pump > filter > heat pump > check valve > chemical feeder pool. Automated chlorine distribution systems, if used, must be placed downstream of the heat pump to minimize harm to the pool equipment. Use rigid PVC piping if possible (SCH40 or SCH80). All joints should be glued with PVC glue. When the piping installation is complete, operate the pool pump and check the system for leaks. Then, check the filter pressure gauge to verify that there isn't any indication of excessive pump head pressure.

You can also make the connections using high-pressureflexible hose, but make sure the hose can withstand high pressure.

l) It is also normal to see water dripping from the drain at the base pan of the unit. While your pool heat pump is in the heating mode, a large volume of warm and humid air passes over the evaporator and causes condensation. To determine if there is a leak, you must stop the heat pump and leave the pool pump running for at minimum 5 hours. If water is still coming out of your heat pump after this period, then call your dealer for service.

1. The wiring of your pool heat pump should be performed by a qualified electrician in accordance with local requirements. A properly-sized breaker and copper wire must be used. Check the heat pump data required maximum breaker size. Because all metals have different electrical potentials, all metal and electrical components of the pool system must be bonded together. This includes the metal framework of the pool, the light, the pump, the filter (if made out of metal), the heat pump, any automatic chlorine generator, and any other metal or electrical equipment. On some older pools, this substructure bond wire may not exist. In these cases, a 6 to 8 foot solid copper rod must be driven into the ground near the equipment. All electric and metal components mu then be bonded to each other, and then to the copper rod.

2. The wiring of your pool heat pump must be performedby a qualified electrician in accordance with national and local requirements.

3. Set leakage protector according to the local code for wiring (leakage operating current \leq 30mA).

4. The layout of power cable and signal cable should be orderly and not affecting each other.

5. Once all wiring and connections have been completed and checked power to the unit can be turned back on.

Connection guide



OPERATION

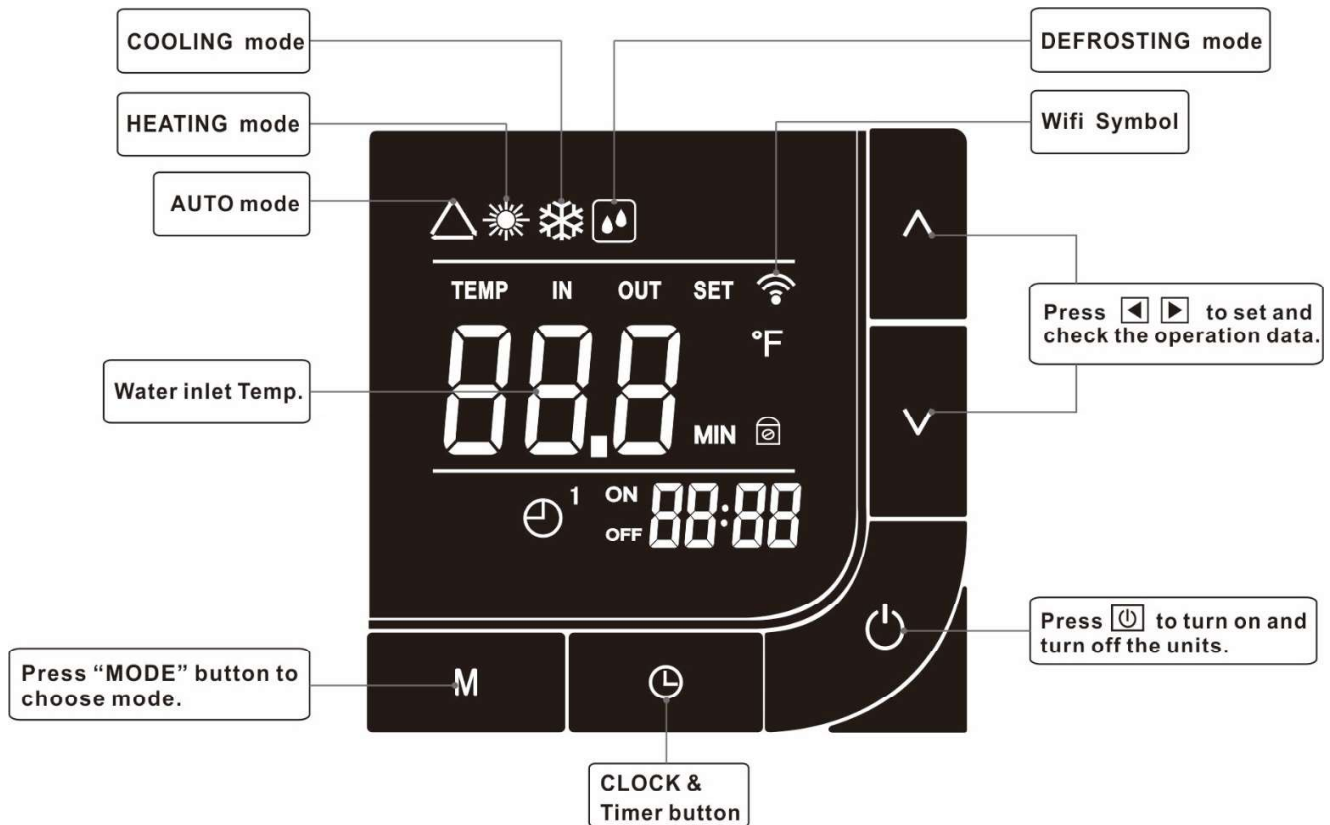

Set the operation parameter:

- ⊙ When the unit powered up but not running, long Press "▲" button 3S to enter operation parameter setting interface.
- ⊙ Press "▲" to check parameter(parameter from P01-P14, see Operation Parameter Table).
- ⊙ Under parameter, press "M" to start setting(the parameter displayed blinks), press "▲" or "▼" to set data for parameter from P01-P14, press "M" again to exit the current parameter settings.
- ⊙ In operation parameter setting interface, press "⏻" button exit to man interface, No operation is maintained in the parameter interface.
- ⊙ If the heat pump is running, press "▲" 3S to check parameter, but can't change parameters.

NO	Meaning	Range	Change	Factory setting
P01	Cooling setting water temperature	50~113°F	YES	79°F
P02	Heating setting water temperature	50~113°F	YES	79°F
P03	Turnround of defrosting Under heat mode	30~90 min	YES	45min
P04	Defrosting start temperature	32~86°F	YES	19°F
P05	Defrost exit temperature	30~86°F	YES	56°F
P06	Time of exit defrost Under heat mode	1~12 min	YES	5 min
P07	Mode (cool/cool & heat/E-heat/heat)	0/1/2/3	YES	1
P08	EEV manual/automatic	0/1	NO	1
P09	Heating Target Superheat	5~59°F	NO	34°F
P10	Cooling Target Superheat	5~59°F	NO	25°F

OPERATION

P11	Auto mode setting water temperature	50~113°F	YES	79°F
P12	Compressor protection Exhaust temperature	185~230°F	NO	203°F
P13	Low ambient temperature protection	-4~50°F	YES	5°F
P14	EEV manual step number	18~94	NO	70

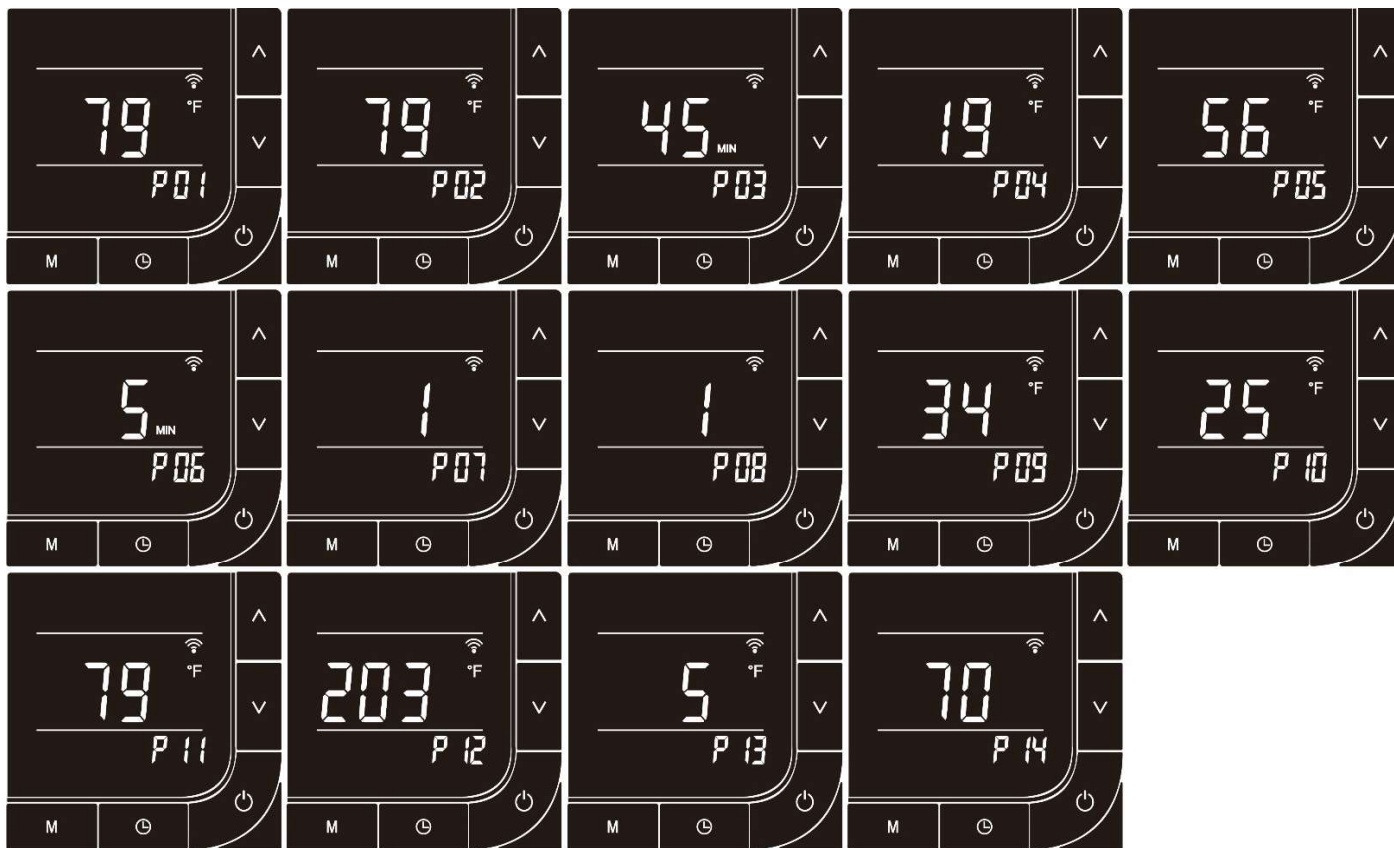

Check system current status

Press “ ∇ ” button 3S to enter check system current status interface.

NO	Meaning	Range	Remarks
A01	Water temperature	-4~210°F	Measured value
A02	Compressor Exhaust temperature	-4~257°F	Measured value
A03	Heating coil temperature	-4~210°F	Measured value
A04	Return gas temperature	-4~210°F	Measured value
A05	Ambient temperature	-4~210°F	Measured value
A06	Cooling coil temperature	-4~210°F	Measured value
A07	Manual Control for EE valve	18~94	Measured value

Real-time clock setting

Press “” + “” button 3S to set clock,

“” symbol will flash during this setting,

Press “” button, it will enter hour setting,

press “” or “” buttons to change the value.



Press “” button once more, it will enter minute setting.



Also press “” or “” buttons to change the value.



After setting, press “” button to back to default screen.



Timer setting

Once the time has been set correctly, this function allows a machine start time and a machine stop time to be programmed during the day

Press “” button 3S the time displayed and “1-NO” to blink. Change the hour using the “” or “” keys.

Press “” button again to change the minutes using the “” or “” keys.

Press “” button the time displayed and “1-OFF” to blink. Change the hour using the “” or “” keys.

Press “” button again to change the minutes using the “” or “” keys.

Press “” button again the display returns to normal.

The time setting is from 0 to 24 hours to recycle.

When the setting timer for on and off is the same, the setting timer is not available.



When the setting timer (displayed blinks), Press “M” to deactivate TIMER.

Coercive Defrosting:

1. press “M” bottom 5 seconds when the unit is heating mode, the unit go to defrost state.
2. When fulfilled defrost stop conditions, defrost is stopped.

Key lock:

Long press “” and “” button 3 seconds, To set keylock.

Long press “” and “” button 3 seconds again to release keylock.

TESTING

Inspection before use

- Check installation of the whole machine and the pipe connections according to the pipe connection diagram
- Check the electric wiring according to the electric wiring diagram; and make sure the Heat Pump is bonded
- Make sure that the main machine power switch is off
- Check the temperature setting.
- Check the air inlet and outlet.

Trial

- The user must “Start the Pump before the Machine, And Turn off the Machine before the Pump”, or the machine will be damaged
- The user should start the pump, check for any water leakage of water; set temperature in the thermostat, and then switch on power supply.
- In order to protect the swimming pool heat pump, the machine is equipped with a time delay starting function, when starting the machine, the blower will run for 3 minutes before the compressor starts.
- If at any time there is an abnormal noise, smell, smoke, electricity leakage, please switch off power immediately and contact your local dealer.

Attention

- Set temperature control to achieve a comfortable water temperature and to avoid overheating or over cooling.
- Always install the machine outdoors, while noting the minimal clearances needed for proper operation and heating. DO NOT place the unit next to shrubs, fences, etc. which can block the air inlet. These locations deny the unit a continuous source of fresh air which reduces its efficiency and may prevent adequate heat delivery.
- Never put hands or any objects into outlet of the swimming pool heat pump, and don't remove the screen over the fan at any time.
- If at any time there is an abnormal noise, odor, smoke, electricity leakage, please switch off power immediately and contact your local dealer.
- Do not use or stock combustible gas or liquids such as paint thinners, paint, fuel near or around the heat pump.
- As with all pool heat pumps, you are advised to use a pool cover at night and when the pool is not in use.
- The heat pump should be installed within 10m of the pool to minimize heat loss in the underground pipes.

Safety

Please keep the main power supply switch out of reach from children.

- If there is a power outage while the machine is in operation, the heat pump will start up automatically when power is restored.
- Please switch off the main power supply during lightning storms to prevent any damage to the unit. If the machine is stopped for a long time, please cut off the power supply and drain water of the machine by opening the tap of inlet pipe. If the unit is stopped for a long period of time or for winterizing, the unit must be drained of all its water. You will need to disconnect the IN and OUT water connections. Then the unit must be tilted or blown out with air until all water is out.

MAINTENANCE

- i. Disconnect power supply of the heat pump before any examination and repair. The unit must always be powered off before opening the access panel. Always cut off the unit's main power whenever the access panel is open or removed.
- ii. In winter seasons, please drain water clear of the machine, disconnect power supply to prevent any machine damage, and cover the machine body with plastic cover to avoid dust. If the unit is stopped for a long period of time or for winterizing, the unit must be drained of all its water. You will need to disconnect the IN and OUT water connections. Then the unit must be tilted or blown out with air until all water is out.
- iii. Please clean this machine with household detergents or clean water, NEVER gasoline, thinners or any similar fuel. The area around the unit should be dry, clean and well ventilated. Clean the side heating exchanger regularly to maintain good heat exchange and conserve energy. Dirt can accumulate on the evaporator. You can easily remove it by using a non-pressured water spray without damaging the small aluminum fins. The cleaning of the plastic cabinet can be done with the help of a brush and soap.
- iv. Check bolts, cables and connections regularly.

TROUBLESHOOTING

Faulty	Reason	Solutions
Not starting	Main power is off	Wait for power to be reinstated
	Switch off	Switch on
	Burnt out fuse	Replace it
	Circuit breaker drops out	Switch Circuit Breaker back on
There is air outlet but the heating is not satisfactory	Blocked air inlet	Clean out the stem
	Blocked air outlet	Clean out the stem
	3 minutes time lag protection	Please wait
	Temperature set too low	Increase temperature setting accordingly
If the above mentioned faults cannot be solved, please contact the professional and inform detailed faulty condition.		

TROUBLESHOOTING

b) This table explains the error codes caused by a defective regulating component.

Display	Problem	Cause	Solution
E20	“WATER IN” sensor out of order	Sensor open or short-circuited	Check or replace the sensor
E10	“Compressor exhaust” sensor out of order	Sensor open or short-circuited	Check or replace the sensor
E09	“HEATING COIL PIPE” sensor out of order	Sensor open or short-circuited	Check or replace the sensor
E12	“Return Gas” sensor out of order	Sensor open or short-circuited	Check or replace the sensor
E04	“AIR” sensor out of order	Sensor open or short-circuited	Check or replace the sensor
E25	“COOLING COIL PIPE” sensor out of order	Sensor open or short-circuited	Check or replace the sensor
E14	First anti-frost protection active	Low temperatures for water and air	No action required
	Second anti-frost protection active	Low temperatures for water and air	No action required
PP9	Low ambient temperature protection	Ambient temperature is too low or protection temperature setting set too high	Check and repair.
E05	High pressure protection	Insufficient water flow	Check the water flow
		Pressure switch out of order	Replace the pressure switch
		Too much refrigerant gas present	Have the heat pump checked by a refrigeration technician
E06	Low pressure protection	Not enough refrigerant gas	Have the heat pump checked by a refrigeration technician
		Leak in the cooling conduits	Have the heat pump checked by a refrigeration technician
E03	Insufficient water flow	Insufficient water flow	Check the water flow
		Water flow switch out of order	Replace the Water flow switch
PEE	Phase Protection	Faulty phase wiring	Put phases in order
E07	compressor exhaust temperature is too high	Water temperature and environmental temperature is too high	Set to the safety of water temperature.
		Refrigerant leakage	Check and repair.
		Insufficient water flow	Check the water flow
E08	Communication failure	No communication between the digital display and the system controller	Check the connection between the screen and the controller. Replace screen and/or controller.
PE2	Emergency switch disconnect	Emergency switch disconnect	Check and repair.

PARTS INFORMATION

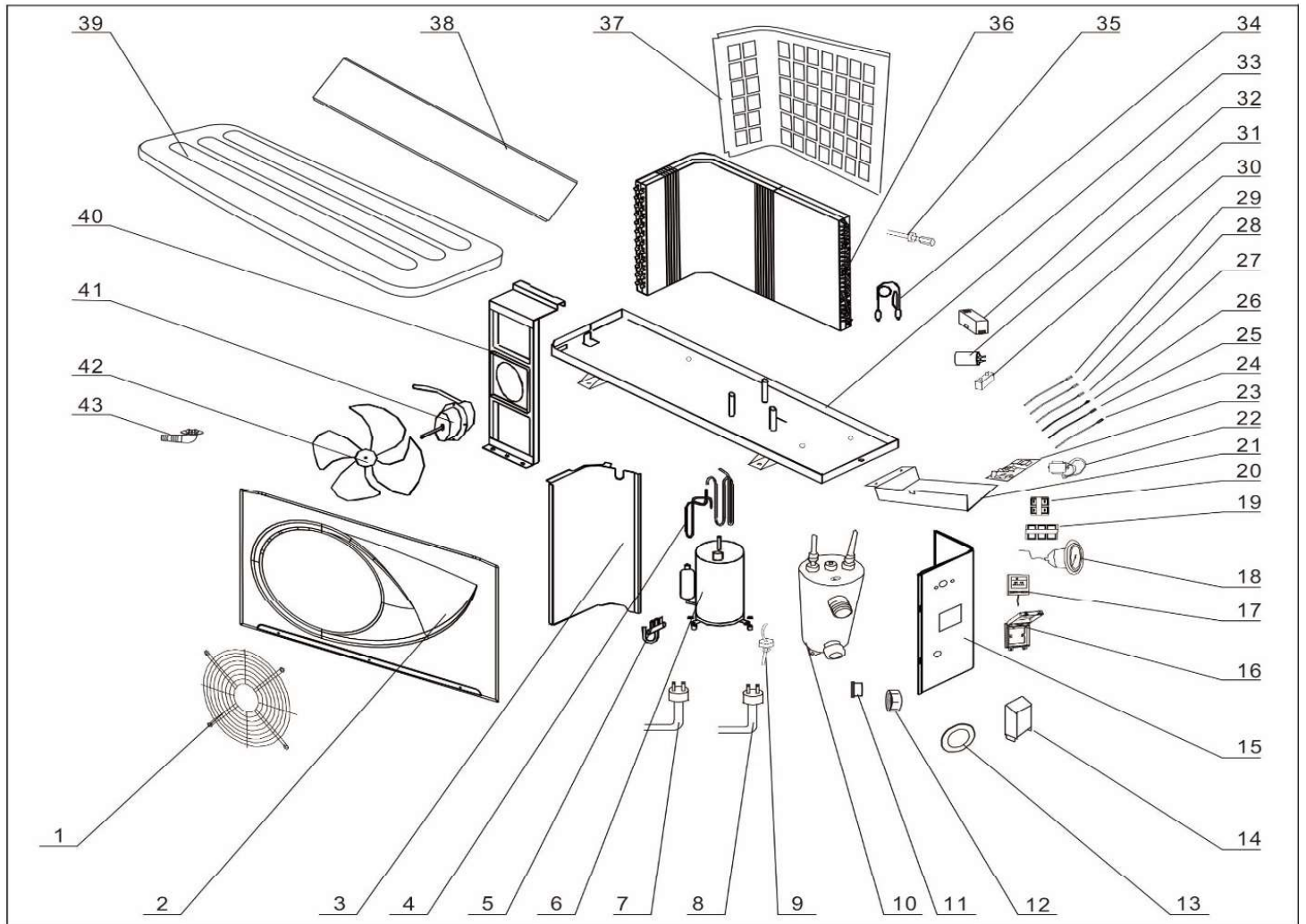

1	Fan protection net	17	Wire controller	33	Frame
2	Front panel	18	Pressure manometer	34	Capillary
3	Verge board	19	Terminal	35	Refrigerant charge valve
4	Copper pipe	20	Public terminal	36	Condenser
5	Four way valve	21	Electrical box	37	Rear net
6	Compressor	22	Transformer	38	Up frame
7	High pressure interruptor	23	Circuit board	39	Top cover
8	Low pressure interruptor	24	Copper sensor	40	Motor bracket
9	Water flow switch	25	Water sensor	41	Fan motor
10	Titanium heat exchanger	26	Ambient sensor	42	Fan
11	Water connection kit	27	Compressor sensor	43	Drain tube
12	Joint water connection kit	28	Cooling copper sensor		
13	Rubber water fender	29	Return gas sensor		
14	Wiring box cover	30	Motor capacitor		
15	Right rear board	31	Compressor capacitor		
16	Control panel cover	32	AC Contactor		

DISCLAIMER

PLEASE READ THE FOLLOWING CAREFULLY

THE MANUFACTURER AND/OR DISTRIBUTOR HAS PROVIDED THE PARTS LIST AND ASSEMBLY DIAGRAM IN THIS MANUAL AS A REFERENCE TOOL ONLY. NEITHER THE MANUFACTURER OR DISTRIBUTOR MAKES ANY REPRESENTATION OR WARRANTY OF ANY KIND TO THE BUYER THAT HE OR SHE IS QUALIFIED TO MAKE ANY REPAIRS TO THE PRODUCT, OR THAT HE OR SHE IS QUALIFIED TO REPLACE ANY PARTS OF THE PRODUCT. IN FACT, THE MANUFACTURER AND/OR DISTRIBUTOR EXPRESSLY STATES THAT ALL REPAIRS AND PARTS REPLACEMENTS SHOULD BE UNDERTAKEN BY CERTIFIED AND LICENSED TECHNICIANS, AND NOT BY THE BUYER. THE BUYER ASSUMES ALL RISK AND LIABILITY ARISING OUT OF HIS OR HER REPAIRS TO THE ORIGINAL PRODUCT OR REPLACEMENT PARTS THERETO, OR ARISING OUT OF HIS OR HER INSTALLATION OF REPLACEMENT PARTS THERETO.

Record Product's Serial Number Here: _____

Note: If product has no serial number, record month and year of purchase instead.

Note: Some parts are listed and shown for illustration purposes only and are not available individually as replacement parts.

The material in this manual is for informational purposes only. The product(s) it describes are subject to change without prior notice, due to the manufacturer's continuous development program. XtremePowerUS makes no representations or warranties with respect to this manual or with respect to the products described herein. XtremePowerUS shall not be liable for any damages, losses, costs or expenses, direct, indirect or incidental, consequential or special, arising out of, or related to the use of this material or the products described herein.

Questions, issues or missing parts?

Before returning to your retailer, our customer service team is here to help.



Call Us: 909.628.0880

Email Us: customer@xtremepowerusa.com

Hours of Operation: 9am - 3pm PST Monday - Friday

MADE IN CHINA