

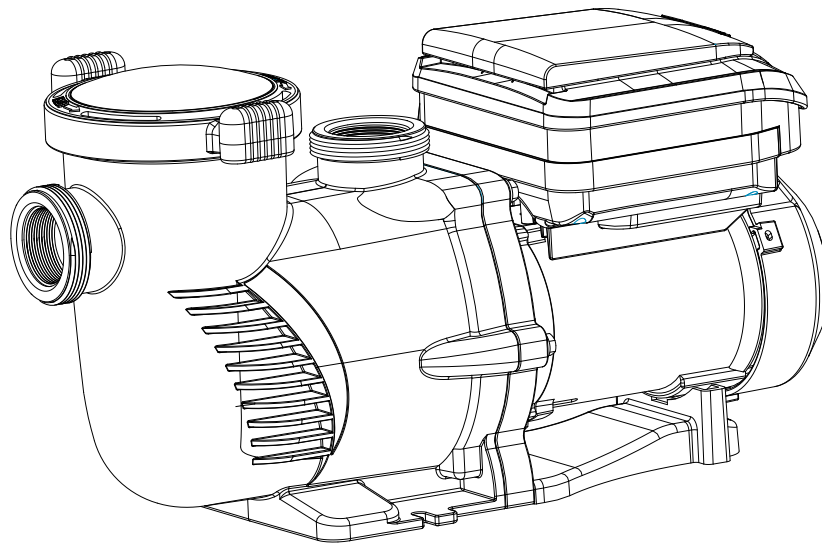

VARIABLE SPEED PUMP
1.75HP 230V 2 INCH

SKU: 75408



INSTALLATION AND USER'S GUIDE

⚠ DANGER

Read all safety warnings and instructions. Failure to follow the warnings and instructions may result in serious injury. Save all warnings and instructions for future reference.

75408

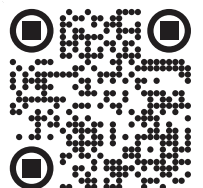

THIS PAGE INTENTIONALLY LEFT BLANK

TABLE OF CONTENTS

TABLE OF CONTENTS	1
IMPORTANT SAFETY INSTRUCTIONS	2
<i>Legends and Symbols</i>	2
OVERVIEW (PRODUCT INFORMATION)	4
PRODUCT INTRODUCTION	4
SPECIFICATION	5
DIMENSIONS	5
INSTALLATION	6
LOCATION	6
PIPING	7
ELECTRICAL INSTALLATION	8
OPERATION	10
INITIAL SETUP	10
KEYPAD FUNCTIONS	11
INITIAL PROGRAMMING	12
SETTING THE CLOCK	12
USING THE DEFAULT SCHEDULE	12
CUSTOM SCHEDULE PROGRAMMING	13
OPERATING THE PUMP IN ACTIVE MODE	15
PROGRAMMING QUICK CLEAN	16
FACTORY RESET	17
PRIMING	18
MAINTENANCE	20
CLEANING THE PUMP STRAINER BASKET	20
MOTOR CARE	21
PUMP DISASSEMBLY AND REASSEMBLY	22
PUMP RESTARTING	23
WINTERIZING	24
TROUBLESHOOTING	25
REPLACEMENT PARTS	28
DISCLAIMER	29
<i>Disclaimer</i>	29
<i>Customer Service and Technical Support</i>	29

IMPORTANT SAFETY INSTRUCTIONS

IMPORTANT SAFETY INSTRUCTIONS

This guide provides instructions for installing and using the VARIABLE SPEED PUMP. If you have any questions about the equipment, please contact XtremepowerUS.

This guide contains important information about safely installing and operating this product. After installation, make sure to share this information with the owner/operator or leave it with them for their reference.

Legends and Symbols

When you come across the safety-alert symbol on your equipment or in this manual, pay attention to the following signal words and remain vigilant about the potential for personal injury.

 **DANGER:** Ignoring these hazards can result in death, severe personal injury, or significant property damage.

 **WARNING:** Indicates potential hazards that can result in severe personal injury, death, or significant property damage. Ignoring these warnings presents a real danger.

 **CAUTION:** Indicates potential hazards that can result in minor or moderate personal injury, property damage, or actions that are unpredictable and unsafe. Ignoring these cautions presents a potential hazard.

 **NOTE:** This label indicates important special instructions that are not directly related to hazards.

USE OF NON-XTREMEPOWERUS REPLACEMENT PARTS VOIDS WARRANTY

ATTENTION INSTALLER: This manual contains vital information regarding the installation, operation, and safe use of this product. It is essential to provide this manual to the end user of the product. Failure to read and follow all instructions could lead to severe injuries.

 **DANGER** Failure to comply with all instructions and warnings may lead to severe bodily injury or even death. For optimal safety and functionality, it is advisable to have the product installed and serviced by a certified service professional. Prior to using this product, installers, operators, and owners must carefully review these warnings and all instructions provided in the owner's manual. It is essential to leave these warnings and the owner's manual with the owner for their reference and safety.

 **WARNING** For safety reasons, children should not be allowed to use this product. Packing materials and plastic bags are not toys. Keep them away from children to prevent the risk of suffocation.

IMPORTANT SAFETY INSTRUCTIONS

⚠ DANGER

- **Suction Entrapment Risk:** High suction can trap and drown individuals near drains or broken covers. Avoid using the pool or spa if drain covers are missing, cracked, or damaged.
- **Electrical Hazard:** Never open the pump's drive or motor enclosure to avoid electrical hazards.



SUCTION ENTRAPMENT HAZARD

⚠ WARNING

- **Qualified Installation:** Pool pump installation and servicing should only be performed by a qualified pool service professional.
- **Correct Application:** Avoid using the pump in settings for which it was not designed, as improper usage can lead to injury or death.
- **Adult Supervision:** This product is not suitable for use by children without adult supervision.
- **Ensure Safe Operation:** Only install the pump in applications that match its intended design.
- **High-Pressure Hazard:** Pool circulation systems operate under high pressure, which can lead to serious injury if improperly handled.
- **Start-Up Precautions:** Stand clear of the system during start-up to avoid potential hazards from pressure surges.

⚠ CAUTION

- **System Sizing and Installation:** Ensure that pumps are properly sized and installed to avoid injury, system damage, or compromised performance.
- **Suction entrapment hazard:** Stay off the main drain and away from suction outlets.
- **Anti-Entrapment Covers:** Ensure properly installed and secured anti-entrapment covers are in place to prevent hazards. Maintain distance from main drains and suction outlets. If possible, disable suction outlets or convert them to return inlets.
- **Code Compliance:** All suction plumbing installations must comply with national and local codes.

★ NOTE

- **Intended Use:** This pump is for permanent swimming pools and compatible hot tubs or spas. It is not for use with storable pools.
- **Manual and Label Adherence:** Review the product manual for important operation and maintenance guidelines.
- **Safe Electrical Setup:** Electrical installations must allow for safe operation without exposing users to electrical risks.
- **Safety Labels:** Maintain safety labels in good condition for clear visibility of hazards and replaced if damaged.
- **Air Relief:** Before starting the system, open the air relief valve and confirm all system valves are open to avoid pressure buildup.

OVERVIEW (PRODUCT INFORMATION)

PRODUCT INTRODUCTION

This pump boasts a variable frequency drive that ensures premium efficiency, allowing for flexible adjustments in motor speed and operation duration. Capable of functioning across a broad speed spectrum of 1000 to 3450 RPM, it is also designed to work with 230 VRMS nominal voltage at both 50HZ and 60HZ frequencies. Engineered to prioritize energy conservation, the pump maintains cleanliness at the lowest necessary speeds, with optimal settings being influenced by pool dimensions, additional water features, sanitation chemicals used, and environmental conditions. Determining the most energy-efficient settings may require a period of trial and optimization.

DRIVE

- User-friendly interface
- Weather-resistant design
- Integrated daily timer
- Adjustable start-up priming
- Programmable Quick Clean function
- Persistent alarm system
- 230V input, compatible with 50/60Hz
- Overload protection circuit
- Clock memory during power cuts

PUMP

- Ultra-quiet operation
- 2-inch connections for straightforward replacement
- Transparent lid for strainer basket monitoring
- Self-priming for fast startup

MOTOR

- High-efficiency, permanent magnet design
- 56 square flange size
- Quiet performance
- Outdoor-rated durability
- Cooler operation through high efficiency
- Surpasses Department of Energy and Energy Star standards
- TEFC (totally enclosed fan-cooled) motor with permanent magnets

OVERVIEW (PRODUCT INFORMATION)

SPECIFICATION

SKU	75408
Power	1.75 HP
Connection	2" Inlet/Outlet
Electrical Requirements	230V, 50/60HZ
Maximum Power Consumption	1200 W
Maximum Shaft Horsepower	1.75 HP
Maximum Current	5.5 AMPS
Maximum Flow Rate Per Minute	108 GPM (Gallons Per Minute)
Maximum Head Lift	59.2 FT
Speed Range	1000 ~ 3450 RPM (Revolutions Per Minute)
Hydraulic Horsepower (HHP)	0.631
Total Horsepower (THP)	1.75
Protection Rating	IPX 5 (Water Resistant)
Storage Temperature Range	-40°F ~ 140°F
Operating Temperature Range	32°F ~ 122°F
Humidity Tolerance	0% ~ 95% Relative Humidity, Non-Condensing

DIMENSIONS

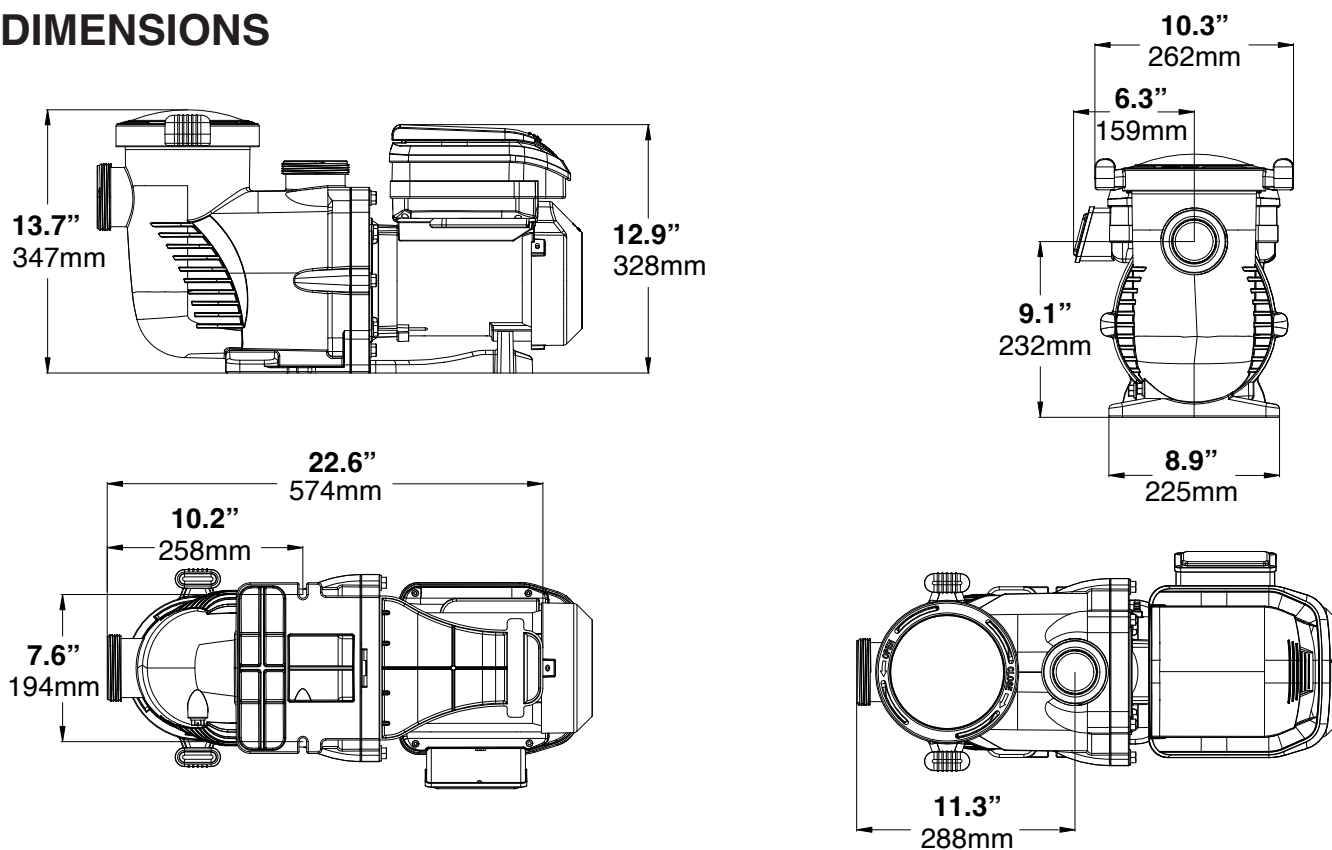

INSTALLATION

INSTALLATION

- Installation should be performed only by a qualified plumbing professional to ensure proper setup and to mitigate safety risks.
- Refer to the IMPORTANT SAFETY INSTRUCTIONS on pages i–ii and 2–3 for detailed safety and installation guidance.

LOCATION

★ NOTE

- Do not install the pump in an enclosed space, such as an external enclosure or under a hot tub or spa skirt.
- Ensure that the pump is securely attached to a stable equipment pad for optimal performance.

LOCATION REQUIREMENTS

- Place the pump close to the pool or spa, using short, direct piping for both suction and return lines to reduce friction loss and increase efficiency.
- Maintain a minimum distance of 5 feet from the pool or spa's inner wall (9.8 feet in Canada).
- Keep the pump at least 3 feet away from the heater outlet.
- Avoid placing the pump more than 5 feet above the water level to prevent operational issues.
- Install the pump in a well-ventilated area, away from moisture sources such as rain gutters and sprinklers.
- Leave at least 3 inches of clearance at the rear for motor removal and 5 inches on top for keypad accessibility (see **Figure 1**).

FIGURE 1

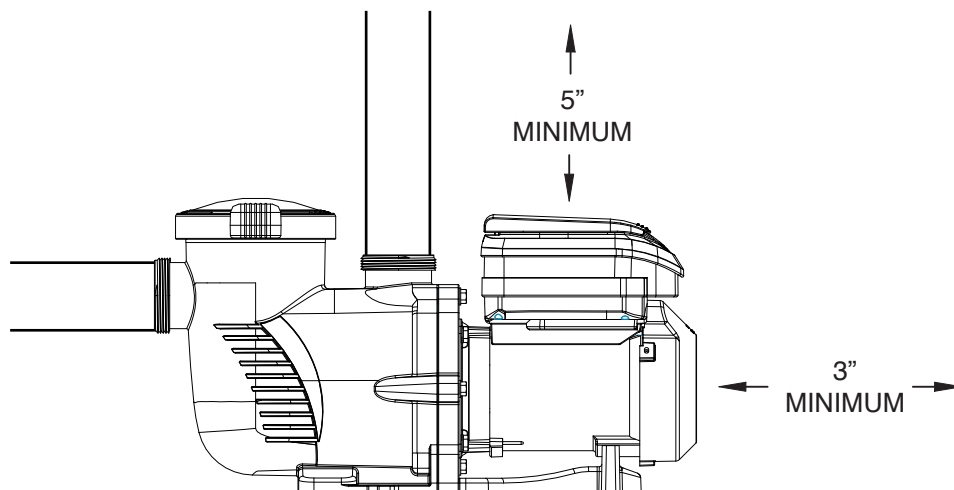

INSTALLATION

PIPING

PIPING GUIDELINES

- Use larger piping to increase plumbing efficiency, ensuring that the suction side pipe diameter is equal to or larger than that of the return line to facilitate optimal flow.
- Ensure that the suction side pipe diameter is equal to or larger than the return line to facilitate optimal flow.
- Keep the suction side piping as short as possible to enhance pump performance.
- Maintain a straight section of pipe on the suction line that is at least five times the pipe's diameter before the pump's inlet. Refer **Figure 2**.
- Example: For a 2.5-inch diameter pipe, ensure at least 12.5 inches of straight piping before the suction port. This setup improves priming speed and extends the lifespan of the pump by reducing turbulence.

FIGURE 2

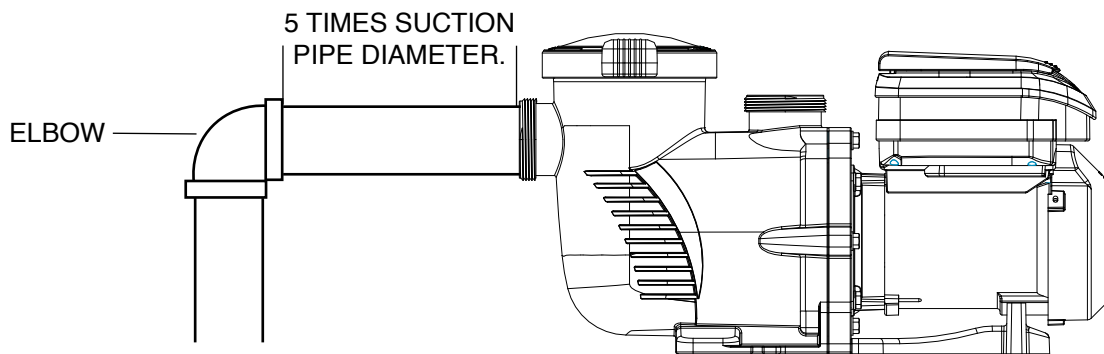

FITTINGS AND VALVES

★ NOTE

- To reduce turbulence and prevent cavitation, avoid placing 90° elbows directly at the pump's suction port (see **Figure 2**).

FITTINGS AND VALVES GUIDELINES

- For flooded suction systems, install gate valves on both the suction and discharge pipes to allow for easy isolation during maintenance.
- Position the suction gate valve at least five times the suction pipe's diameter away from the pump to prevent interference with flow dynamics.
- Install a check valve on the discharge line, especially if the plumbing has a significant rise after the pump, to prevent water backflow and help maintain consistent pump performance.
- When plumbing two pumps in parallel, install check valves on each pump's discharge line to prevent reverse rotation of the impeller and motor, which can occur if one pump is running while the other is off or during fluctuations in flow.

INSTALLATION

ELECTRICAL INSTALLATION

WARNING

- Risk of Electrical Shock or Electrocution: It is strongly recommended that a certified electrician or qualified professional install this pump in accordance with the National Electrical Code and local regulations to mitigate the risk of serious injury, death, or property damage.
- Always disconnect power at the circuit breaker before servicing to prevent electric shock or injury.
- Read all instructions carefully before servicing the pump.

NOTE

- The pump is designed to operate with a 230 V single-phase input, compatible with both 50 and 60 Hz. Its power connections support up to 8 AWG solid or stranded wire.

WIRING INSTRUCTIONS

- Turn off all breakers and switches before beginning motor wiring.
- Verify that the supply voltage matches the motor's nameplate specifications.
- Adhere to the National Electrical Code and local codes for wire sizes and requirements; select a heavier gauge wire if uncertain.
- Ensure all electrical connections are secure and free of corrosion. Trim wires to fit terminals precisely, avoiding excess overlap or contact. Trim wiring to fit terminals without excess overlap or contact.
- Always replace the drive lid after completing wiring or when leaving the pump unattended to protect it from the elements.

NOTE

- Take care not to pinch wires when securing the drive body and lid.

GROUNDING INSTRUCTIONS

- Ensure the motor is permanently grounded using the Grounding Terminal located in the drive's wiring compartment. Comply with the National Electrical Code and local regulations regarding the grounding wire's size and type."
- Attach the ground wire to the electrical service's ground.

INSTALLATION

BONDING INSTRUCTIONS

- Connect the motor to the pool's structural metal components, electrical systems, and metal conduits and piping within 5 feet of the pool or spa's inner walls using the provided bonding lug on the motor's side. Comply with the current National Electrical Code and local codes for bonding practices.
- A solid copper conductor of at least 8 AWG is required for bonding. For installations in Canada, a 6 AWG or thicker solid copper conductor is necessary.

FIGURE 3

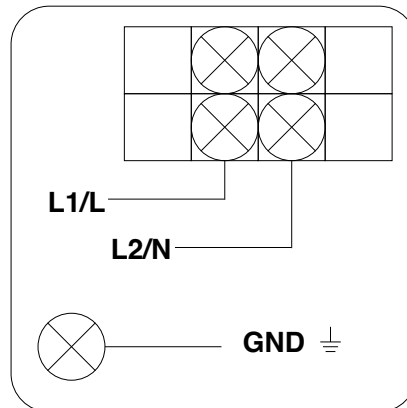

OPERATION

INITIAL SETUP

- Before initial use of the pump, program its internal clock and operational schedules. Instructions for setting the clock are available under **SETTING THE CLOCK** and **USING THE DEFAULT SCHEDULE**. For custom schedule programming, see **CUSTOM SCHEDULE PROGRAMMING**.
- The drive keypad allows programming and control of the pump and provides access to all features and settings.

NOTE

- The pump's functionality may vary if features like External Control Only Mode or Keypad Lockout are enabled.
- Close the keypad cover after each use to protect the keypad and drive components from potential damage.

CAUTION

- To avoid damaging the keypad, use only your fingers to press the buttons; do not use screwdrivers, pens, or other tools for programming the pump.

WARNING

- If the pump motor is connected to power, pressing any buttons mentioned in this section may activate the motor. Unexpected motor start-ups could result in personal injury or equipment damage. Always be aware of the motor's power status when programming or servicing.

OPERATION

KEYPAD FUNCTIONS

FIGURE 4

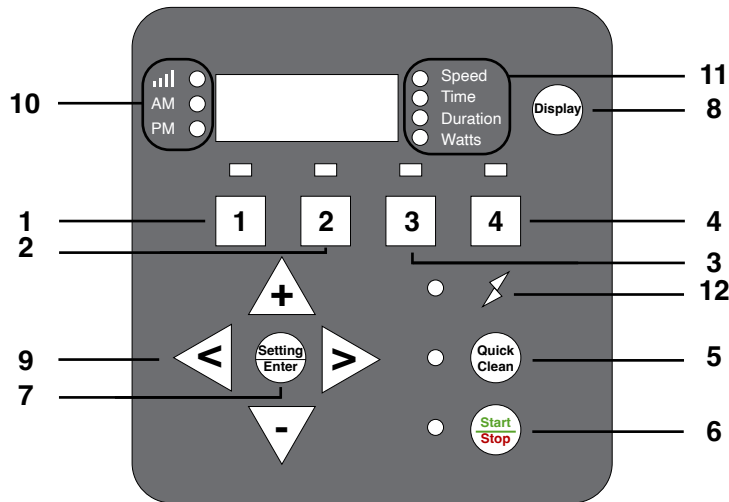

- 1 SPEED 1** Press to activate Speed 1 (2850 RPM).
The corresponding LED will illuminate to confirm that Speed 1 is active.
- 2 SPEED 2** Press to select Speed 2 (1730 RPM).
An illuminated LED indicates that Speed 2 is active.
- 3 SPEED 3** Press to select Speed 3 (2300 RPM).
The LED light confirms that Speed 3 is active.
- 4 SPEED 4** Press to select Speed 4 (1150 RPM).
An illuminated LED indicates that Speed 4 is active.
- 5 QUICK CLEAN KEY** Dedicated button for Quick Clean function.
- 6 START / STOP KEY** Press to start or stop the pump. A lit indicator signifies that the pump is operational or in a specific. A blinking indicator light shows that the pump is off and awaiting the next scheduled mode.
- 7 MAIN MENU ACCESS** Press to enter the main menu directory when the frequency converter is powered down.
- 8 DISPLAY BUTTON** Press to switch between different display contents during pump operation.
- 9 ARROW KEYS**
 - UP KEY** Press to increase speed or time during adjustments.
 - DOWN KEY** Press to decrease speed or time during adjustments.
 - LEFT KEY** Press to move the cursor to the left.
- 10 CONTROL PANEL DIGITAL DISPLAY** The display screen shows various operational parameters, such as current speed, time, duration, power consumption, Bluetooth connectivity status, and more.
- 11 DISPLAY MODE LED INDICATOR** Works in conjunction with the display button. The LED lights up to match the information shown on the digital display. A blinking LED indicates that the current parameter can be edited.
- 12 POWER LED INDICATOR** An illuminated LED indicates that the pump is powered and receiving energy

OPERATION

INITIAL PROGRAMMING

- Before first use, set the pump's internal clock and operational schedules as detailed in this manual. Refer to *Setting the Clock* in this section and **CUSTOM SCHEDULE PROGRAMMING** for step-by-step instructions.

★ NOTE

- When setting up a new schedule, ensure that the start times for Speeds 1 through 4 are programmed in chronological order within a 24-hour period.

SETTING THE CLOCK

- When the pump is first connected to power, the clock will flash, indicating the need for setup.
- Press Setting. Use the + and - buttons to set the current time, < and > to adjust the cursor position. In 12-hour format, AM/PM will be displayed.
- In 12-hour format, AM/PM will be displayed.

USING THE DEFAULT SCHEDULE

- The default schedule provides adequate daily circulation for most pools (see Table 2 for details).

PROGRAM	STARTUP TIME	OPERATION DURATION	DEFAULT SPEED
SPEED 1	8:00AM (8:00) (ADJUSTABLE)	2 HRS (ADJUSTABLE)	2850 RPM (ADJUSTABLE)
SPEED 2	10:00AM (10:00) (ADJUSTABLE)	10 HRS (ADJUSTABLE)	1730 RPM (ADJUSTABLE)
SPEED 3	8:00AM (20:00) (ADJUSTABLE)	2 HRS (ADJUSTABLE)	2300 RPM (ADJUSTABLE)
SPEED 4	10:00AM (22:00) (ADJUSTABLE)	8 HRS (ADJUSTABLE)	1150 RPM (ADJUSTABLE)

★ NOTE

THE DEFAULT OPERATING CYCLE OF THE PUMP IS SET TO RUN FOR 22 HOURS PER DAY.

DEFAULT SCHEDULE OPERATES

- **SPEED 1:** Starts at 8:00 AM, runs at 2850 RPM for 2 hours.
- **SPEED 2:** Starts at 10:00 AM, runs at 1730 RPM for 10 hours.
- **SPEED 3:** Starts at 8:00 PM, runs at 2300 RPM for 2 hours.
- **SPEED 4:** Starts at 10:00 PM, runs at 1150 RPM for 8 hours.
- Following **SPEED 4**, the pump pauses for 2 hours and then resumes with **SPEED 1**. This cycle repeats, maintaining a 22-hour daily operation as set by the factory until altered by the user.

★ NOTE

To start the pump, press the Start/Stop button and ensure that the corresponding LED is illuminated.

OPERATION

CUSTOM SCHEDULE PROGRAMMING

- Ensure the pump is halted, with the Start/Stop LED off, before customizing your sch A blinking LED next to the parameter being edited indicates that it is in programming mode.

TO SET A CUSTOM SCHEDULE

1. Press **Start/Stop** to stop the pump.
2. Then, press '1' to edit Speed 1; its LED and 'Speed' will blink (see **Figure 5**).

FIGURE 5

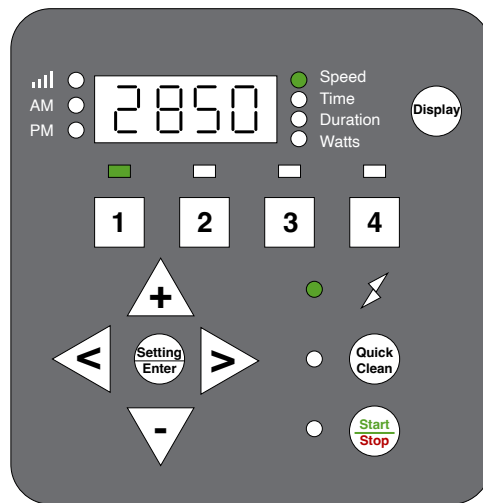

Adjust the Speed 1 RPM using the + and - buttons, and move the cursor with the < and > buttons.

NOTE Speed adjusts in 100/10/1 RPM increments.

4. Press '1' to set the start time for Speed 1; 'Time' will blink (see **Figure 6**).

FIGURE 6

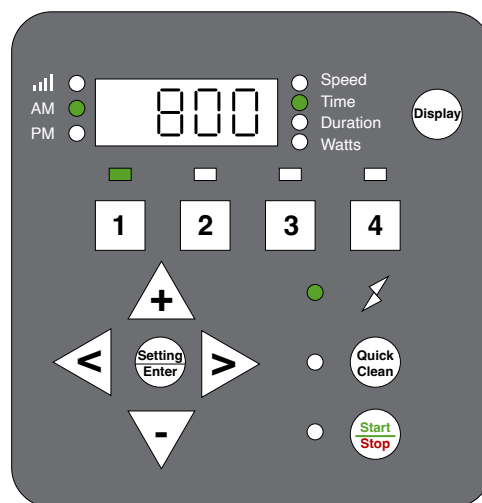

OPERATION

TO SET A CUSTOM SCHEDULE (CONTINUED)

5. Set the start time with the + and - buttons, adjusting the cursor with < and >.

★ NOTE Adjust speed in increments of 100/10/1 RPM, and adjust time in increments of 1 hour/10 minutes/1 minute.

6. Press '1' to set the duration for Speed 1; 'Duration' will blink (see **Figure 7**).

FIGURE 7

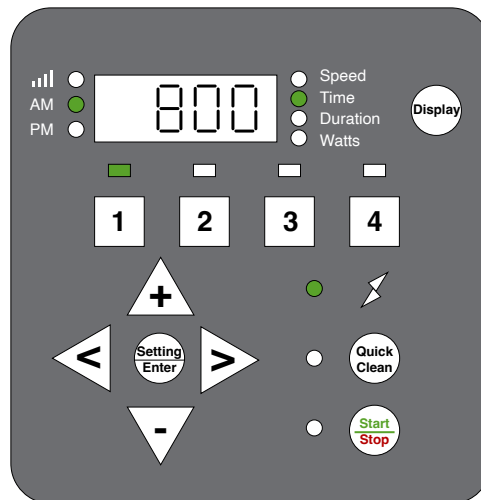

7. Set the duration using the + and - buttons, and adjust the cursor with < and >.

★ NOTE Duration adjusts in increments of 1 hour and 10 minutes.

★ NOTE If set to 0, the pump will skip this segment.

8. Confirm the Speed 1 setup. Subsequent presses of '1' will cycle through the settings, saving changes instantly.

★ NOTE Pressing 1 cycles through SPEED 1 settings; changes save automatically.

9. To set Speed 2, press '2' and follow the same steps as for Speed 1.

10. Adjust the Speed 2 RPM using the +, -, <, and > buttons.

11. To display the Speed 2 setup, press '2'.

12. Set the Speed 2 duration using the +, -, <, and > buttons.

13. Follow steps 9–12 to set Speed 3, Speed 4, and **Quick Clean** settings.

14. To activate the pump with the new schedule, press **Start/Stop**; the LE will light up.

★ NOTE If the pump was manually stopped, press **Start/Stop** again to start the schedule. A lit **Start/Stop** LED indicates that the pump will follow the set schedule.

OPERATION

SPEED PRIORITIZATION FOR SCHEDULING (WITHOUT EXTERNAL CONTROL)

- When the pump operates based on its internal schedule, the programmed speeds follow a priority sequence from highest to lowest: SPEED 1 has the highest priority, followed by SPEED 2, SPEED 3, and finally, SPEED 4 with the lowest priority.
- The prioritization order is detailed in an accompanying table for reference.

Example:

STARTING SCHEDULE (BEFORE ADJUSTMENT)

- *SPEED 1: Start time = 8:00 AM; Duration = 6 hours*
- *SPEED 2: Start time = 9:00 AM; Duration = 1 hour*
- *SPEED 3: Start time = 10:00 AM; Duration = 1 hour*
- *SPEED 4: Start time = 2:00 PM; Duration = 1 hour*

According to this priority, the pump will run in SPEED 1 mode from 8:00 AM to 2:00 PM, skipping SPEED 2 and SPEED 3, as their time frames fall within the SPEED 1 period. The pump will then run in SPEED 4 mode from 2:00 PM to 3:00 PM

End Schedule (After Adjustment)

- *SPEED 1: Start time = 8:00 AM; Duration = 6 hours*
- *SPEED 4: Start time = 2:00 PM; Duration = 1 hour*

OPERATING THE PUMP IN ACTIVE MODE

⚠ CAUTION

- When the pump is powered, pressing any button described in this section may activate the motor, potentially causing personal injury or equipment damage.

OPERATING THE PUMP IN ACTIVE MODE

- The Display button toggles through active settings including **SPEED** (current RPM), **TIME** (current time), **DURATION** (time left at current speed), and **WATTS** (current power usage).
- Pressing any Speed button (**1**, **2**, **3**, **4**, or Quick Clean) during operation temporarily overrides the current setting. The pump will run at the selected speed for the preset duration, then resume the regular schedule.

★ NOTE

- Changes to schedule speeds during operation apply only for the remaining duration of the active program and will not permanently save these adjustments.

OPERATION

PROGRAMMING QUICK CLEAN

QUICK CLEAN FEATURE SETUP

- The pump includes a Quick Clean option, which allows temporary operation at speeds ranging from 1700 to 3450 RPM. After a Quick Clean cycle, the pump reverts to its scheduled program.
- The drive's prioritization is outlined in an accompanying table for reference.

PROGRAMMING QUICK CLEAN

- Stop the pump by pressing **Start/Stop**, then activate Quick Clean mode; the Quick Clean and 'Speed' LEDs will flash (see **FIGURE 8**).

FIGURE 8

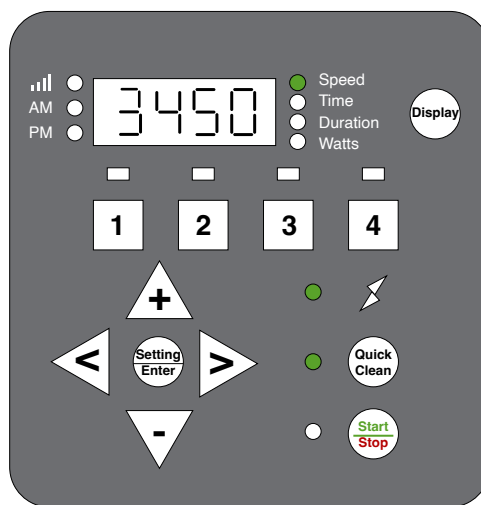

- Set the RPM using the + and - keys, and navigate with < and >.

NOTE RPM can be adjusted in increments of 100, 10, or 1 RPM.

- Press Quick Clean again to set the duration; the 'Duration' LED will blink (see **FIGURE 9**).

FIGURE 9



PROGRAMMING QUICK CLEAN (CONTINUED)

- Adjust the duration in hours and minutes using + and - keys, and navigate with < and >.

 **NOTE** Duration adjustments are available in increments of 1 hour or 10 minutes, with a range from 10 minutes to 24 hours.

 **NOTE** The Quick Clean duration setting will not affect the programmed start time of the regular schedule.

FACTORY RESET

To revert the drive to its default settings, perform a Factory Reset. This action will erase all customized settings and schedules except for the current time of day. Confirm the necessity of this action before proceeding, as the reset takes immediate effect.

FACTORY RESET PROCESS

- Stop the pump by pressing the Start/Stop button if it is currently running.
- Hold down the “1” and “2” buttons simultaneously for 3 seconds.
- A prompt tone lasting 3 seconds will confirm a successful reset

After the reset, reprogram the schedule and priming speed as outlined in previous sections. To activate the pump for subsequent operation, press the **Start/Stop** button; the pump will then follow the newly set schedule."

OPERATION

PRIMING

⚠ CAUTION

- The pump is pre-set to Priming mode, which causes it to automatically accelerate to 3200 RPM upon initial start-up.
- Before activating the pump:
 - Open the filter's air relief valve.
 - Ensure that all necessary valves are open.
 - Confirm that the return line is unobstructed.
 - Fill the pump with water.
 - Maintain a safe distance from the filter and any pressurized vessels.

⚠ WARNING

- Never run the pump dry, as it will damage the shaft seal and cause leaks.
- Replace any damaged seal immediately to prevent leaks.
- Maintain the proper water level in your pool (at least halfway up the skimmer opening) to prevent air from being drawn through the skimmer.
- A low water level can cause the pump to lose its prime, potentially leading to seal damage.
- Continuous operation with a compromised seal can damage the pump body and impeller, and may lead to personal injury and property damage.

STARTUP AND PRIMING PROCESS

- At startup, the pump automatically begins a priming cycle, separate from any Quick Clean cycle. It starts at 2400 RPM and gradually increases to 3200 RPM over 5 minutes, with the drive displaying the time remaining.

★ NOTE

- If the control system's priming timer is still running after the priming cycle, the pump will continue at the control system's set speed until the timer expires.
- The startup speed can be adjusted between 3200 RPM and 3450 RPM using the '+' and '-' buttons during boot-up.

★ NOTE

- The initial boot begins with a 5-minute countdown. Press any Speed button (1 to 4) to exit the priming mode prematurely.
- Upon subsequent startups, the pump will assess the need for priming, taking approximately 20 seconds to determine if priming is required.

OPERATION

STARTUP AND PRIMING PROCESS (CONTINUED)

- Priming duration may vary with local conditions, such as water temperature, atmospheric pressure, and pool water level, which should all be considered when selecting the priming speed. Test and adjust priming speeds as needed, allowing the system to drain between tests.

NOTE

- To avoid air intake into the system, ensure the pump strainer pot is filled with water up to the bottom of the suction port.

MAINTENANCE

⚠ WARNING

STRAINER POT HANDLING

- Never open the strainer pot if the pump has failed to prime or has operated without water, as vapor pressure build-up may cause scalding water inside.
- Opening under these conditions can lead to severe injury.
- Ensure both suction and discharge valves are open, and verify that the strainer pot is cool before cautiously opening it.

POWER DISCONNECTION

- Always turn off power at the circuit breaker and disconnect the digital input cable before servicing the pump. Failing to do so may result in fatal or severe electric shock injuries.
- Neglecting this step can cause fatal or severe electric shock injuries. Read and understand all service instructions prior to performing pump maintenance.

⚠ CAUTION

PUMP MAINTENANCE

- To prevent pump damage and maintain system efficiency, regularly clean the pump strainer and skimmer baskets.

CLEANING THE PUMP STRAINER BASKET

The strainer pot, located at the front of the pump, contains the strainer basket. Inspect the basket through the pot lid visually at least once a week. Regular cleaning ensures higher efficiency of the filter and heater and reduces stress on the pump motor.

CLEANING INSTRUCTIONS

- **Stop the pump** by pressing Start/Stop, and turn off electrical power at the circuit breaker.
- **Open the filter's air relief valve** to release any pressure in the filtration system.
- **Unscrew the strainer pot lid** counterclockwise and remove it.
- **Remove the basket**, clear debris, and rinse it. Replace the basket if it is cracked or damaged.
- **Reinsert the basket** into the pot, ensuring the basket's notch aligns with the strainer pot's rib.
- **Refill the strainer pot with water** to the level of the inlet port.
- **Clean the lid's O-ring** and the pot's sealing surface.

★ NOTE Keep the O-ring clean and lubricated.

- **Replace the lid**, screwing it clockwise until the handles are aligned horizontally.

★ NOTE Ensure the O-ring is correctly placed to avoid pinching.

★ NOTE Ensure the "Front" label on the lid faces the front of the pump.

- **Open the filter air relief valve again** and maintain a safe distance from the filter.
- **Restore electrical power** at the circuit breaker and restart the pump.
- **Once a steady water flow** is established from the air relief valve, close the valve.

MAINTENANCE

MOTOR CARE

HEAT PROTECTION

- Shield the motor from direct sunlight, ensuring that any covering provides adequate ventilation to prevent overheating.
- Facilitate cross ventilation around the motor area.

DIRT PROTECTION

- Keep foreign materials away from the motor to avoid contamination.
- Store chemicals at a safe distance from the motor to prevent accidental spills.
- Minimize dust generation near the motor during operation, as dirt damage can void the motor warranty.
- Regularly clean the lid, O-ring, and the sealing surface of the strainer pot to maintain optimal performance.

MOISTURE PROTECTION

- Protect the motor from water splashes or sprays, and shield it from harsh weather conditions.
- If the motor becomes wet internally, allow it to dry thoroughly before use.
- Do not operate a flooded pump, as water damage can void the motor warranty.

WARNING

HIGH-PRESSURE SYSTEM OPERATION

- This system operates under high pressure, so servicing any component in the circulation system can introduce air, leading to pressurization. Such pressurized air may forcefully dislodge the lid, posing serious risks of injury, death, or property damage. To prevent these hazards, follow all provided instructions closely.

MAINTENANCE

PUMP DISASSEMBLY AND REASSEMBLY

★ NOTE

- For a detailed parts breakdown, refer to the **PARTS DIAGRAM** section.

⚠ WARNING

POWER DISCONNECTION

- It is crucial to always shut off power at the circuit breaker before servicing the pump.
- Failing to disconnect the power source can result in potentially fatal electric shock injuries.
- Ensure you fully understand and comply with all servicing guidelines before beginning any maintenance work.

STRAINER POT HANDLING

- Do not open the strainer pot if the pump is having trouble priming or has been operating without water, as these conditions can cause vapor pressure build-up with extremely hot water inside, posing a serious risk if opened.
- For safety, confirm that both the suction and discharge valves are open and that the strainer pot is cool to the touch before attempting to open it. Proceed with extreme caution.

REQUIRED TOOLS

- Adjustable wrench
- #2 Phillips screwdriver
- Flat blade screwdriver

PUMP DISASSEMBLY

- **Stop the pump** using the Start/Stop button and disconnect power at the circuit breaker.
- **Unplug digital inputs or communication cables**, if present.
- **Close all valves** on the suction and discharge lines.
- **Release system pressure** using the filter's air relief valve.
- **Remove the drain plugs** from the bottom of the strainer pot.
- **Unscrew the two through-bolts and nuts** of the strainer pot using an adjustable wrench.
- **Remove the four remaining strainer pot bolts.**
- **Detach the motor/hydraulics assembly** from the strainer pot carefully.
- **Unscrew the diffuser** from the seal plate.
- **Hold the motor shaft** at the motor's rear to prevent it from spinning. Remove the impeller screw and washer.
- **Unscrew the impeller by hand.**
- **Remove the four bolts** from the seal plate using a 9/16 inch wrench.
- **Take off the seal plate** from the motor/drive assembly.

MAINTENANCE

PUMP DISASSEMBLY AND REASSEMBLY (CONTINUED)

PUMP REASSEMBLY

- Align the seal plate on the motor, ensuring the "UP" marking is at the top.
- Attach the seal plate to the motor with bolts, tightening to 70–80 in-lbs.
- Hold the motor shaft and reattach the impeller to the shaft, followed by the impeller screw and washer; tighten to 25 in-lbs.

★ NOTE The impeller screw has reverse threading.

- Reinstall the diffuser onto the seal plate and secure with screws. Replace the diffuser seal and seal plate gasket if necessary, applying lubrication as needed.
- Reattach the strainer pot to the motor/hydraulics assembly with bolts and washers.

★ NOTE Tighten the through-bolts only after all bolts are finger-tightened, then secure to 110 in-lbs.

★ NOTE Ensure the seal plate gasket is properly aligned.

- Replace the drain plugs in the strainer pot.
- Refer to the Pump Restarting section for further instructions on restarting the pump.

PUMP RESTARTING

! CAUTION

Avoiding Dry Running

- Never operate the pump without water, as dry running can damage the shaft seal, requiring immediate replacement.
- Maintain the proper water level in the pool, ideally at least halfway up the skimmer opening, to prevent air intake through the skimmer.
- A low water level can cause the pump to lose prime, leading to decreased pressure, potential pump damage, property damage, or even personal injury.

PUMP RESTARTING PREPARATION

If the pump is installed below the pool's water level, close the return and suction line valves before opening the strainer pot. Ensure these valves are reopened before starting the pump.

PUMP RESTARTING INSTRUCTIONS

- Stop the pump using the Start/Stop button and disconnect power at the circuit breaker.
- Release all pressure in the filtration system by opening the filter's air relief valve.
- Unscrew and remove the strainer pot lid by turning it counterclockwise.
- Fill the strainer pot with water up to the level of the inlet port.
- Replace the lid onto the strainer pot, securing it by turning clockwise.

★ NOTE The lid is correctly locked when its handles are nearly perpendicular to the pump body.

- Restore power to the pump at the circuit breaker.
- Open the filter's air relief valve and stand back from the filter.
- Restart the pump using the Start/Stop button.
- Bleed air through the filter air relief valve until water flows steadily, then close the valve.

WINTERIZING

Be proactive in anticipating freezing conditions, as freeze damage is not covered under warranty. In areas with mild climates where temporary freezing may occur, keep the filtering equipment running overnight to prevent freezing.

PREVENT FREEZE DAMAGE INSTRUCTIONS

- Stop the pump by pressing Start/Stop and disconnect all power at the circuit breaker. Confirm that all power sources are disconnected.
- Release pressure from the filtration system using the filter's air relief valve.
- Remove both drain plugs at the bottom of the strainer pot to drain the pump completely. Store the plugs in the strainer basket for safekeeping.
- Protect the motor by covering it to shield it from heavy rain, snow, and ice.

NOTE

- Avoid using plastic or airtight materials to cover the motor during winter storage.
- Ensure the motor remains uncovered if it will be operational or if the pump is expected to run.

TROUBLESHOOTING

TROUBLESHOOTING

⚠ WARNING

ELECTRICAL SAFETY

- Risk of Electrical Exposure: Diagnosis may require proximity to live components.
- Servicing should only be performed by certified professionals to prevent serious risks, including death, personal injury, or property damage.

ISSUE	CAUSE	CORRECTIVE ACTION
Pump Failure	Pump Will Not Prime: Air in the suction line or pump	Inspect the suction line and valves for any signs of damage or loose connections. Confirm the strainer pot lid is sealed correctly and the O-ring is intact. Check the pool's water level is adequate for the skimmer.
	Pump Will Not Prime: Insufficient water	Make sure the pump strainer pot is filled with water. Ensure that the suction line valve is operational and in the open position (if applicable). Ensure the pool water level is sufficient for the skimmer function.
	The Strainer Basket is Dirty or Full Damaged Strainer Pot O-Ring	Refer to Cleaning the Pump Strainer Basket section and clean the basket to remove debris. Examine the O-ring for wear or damage, and replace it if necessary.
Reduced Pump Capacity and Head	Air in the suction line or pump	Check suction line and valves for any damage or loose connections. Check that the strainer pot lid is securely sealed and that the O-ring is present and correctly positioned. Ensure the pool's water level is at least halfway up the skimmer opening to support skimmer intake.
	Clogged impeller	Refer to Cleaning the Pump Strainer Basket section and clean the basket to remove debris. Refer to CLEANING THE PUMP STRAINER BASKET instruction.
	Dirty or full strainer basket	Inspect the circuit breaker and replace any blown fuses as needed.
Non-Starting Pump	No power from the mains	Check and secure connections to the mains wires.
	Voltage Motor is jammed	Use the Pump Disassembly instructions to manually rotate the motor shaft and clear any obstructions.
	Motor shaft is compromised	The pump may require replacement.
Pump That Runs Then Stops	Overheating (Over Temperature Fault)	Check the motor fan cover located at the back of the motor for any accumulation of dirt and debris.
	Excessive current draw (Over Current Fault)	Clean the fan cover using compressed air to remove any obstructions.

TROUBLESHOOTING

★ NOTE

- The pump is designed to automatically attempt a restart after a one-minute cool down period.

ISSUE	CAUSE	CORRECTIVE ACTION
Noisy Pump	Obstruction by debris in fan area	Check the fan cover located at the rear of the motor for any accumulation of dirt and debris. Use compressed air to clean if needed
	Full or dirty strainer basket	Refer to CLEANING THE PUMP STRAINER BASKET instruction.
	Improperly secured mounting	Check and tighten all mounting bolts and pump bolts to ensure the pump is securely fastened.
Pump Running Without Water Flow	The impeller may be loose.	Verify that the fan at the rear of the pump is active. If it is, proceed to disassemble the pump as directed on page 12 and check that the impeller is properly fitted.
	There could be air in the suction line or pump.	Examine the suction line and valves for any signs of damage or loose connections. Make sure the strainer pot lid is creating a proper seal and that the O-ring is present and correctly positioned. Confirm that the pool has an adequate water level for the skimmer to function effectively.
	Plumbing may be clogged or restricted.	Look for and eliminate any obstructions in the strainer pot or suction line. Check the discharge piping for any blockages, including partially closed valves or a dirty pool filter, and clear any obstructions.

ALARMS AND FAULT CODE GUIDANCE

When an alarm triggers, the drive will halt the pump and display a fault code. To reset, turn off the power and wait for all keypad LEDs to go off before restoring power. If the fault persists, consult the error description table below for troubleshooting.

FAULT CODE DESCRIPTIONS

- **1:** Obstruction, motor wiring issue, short circuit, or excessive temperature rise.
- **2, 4, 6:** Input voltage is too high.
- **8:** Input voltage is too low.
- **16, 128:** Motor does not start under normal conditions.
- **256:** Motor phase loss or poor connection between motor and driver.
- **300:** Pump running without water (no load).
- **301:** Overheating of internal components.

TROUBLESHOOTING

SPECIFIC FAULTS

- **Power Out Failure:** Supply voltage drops below 190 VAC, or the controller's input voltage exceeds the limit.
- **16, 128 - Motor Failure to Start:** May result from a jammed motor, improperly connected ground wire, or incorrect driver installation.
- **300 - No Load:** Indicates the pump may not be drawing water.
- **301 - Over-temperature:** Internal driver components have exceeded their temperature limit.

REPLACEMENT PARTS

REPLACEMENT PARTS PARTS DIAGRAM

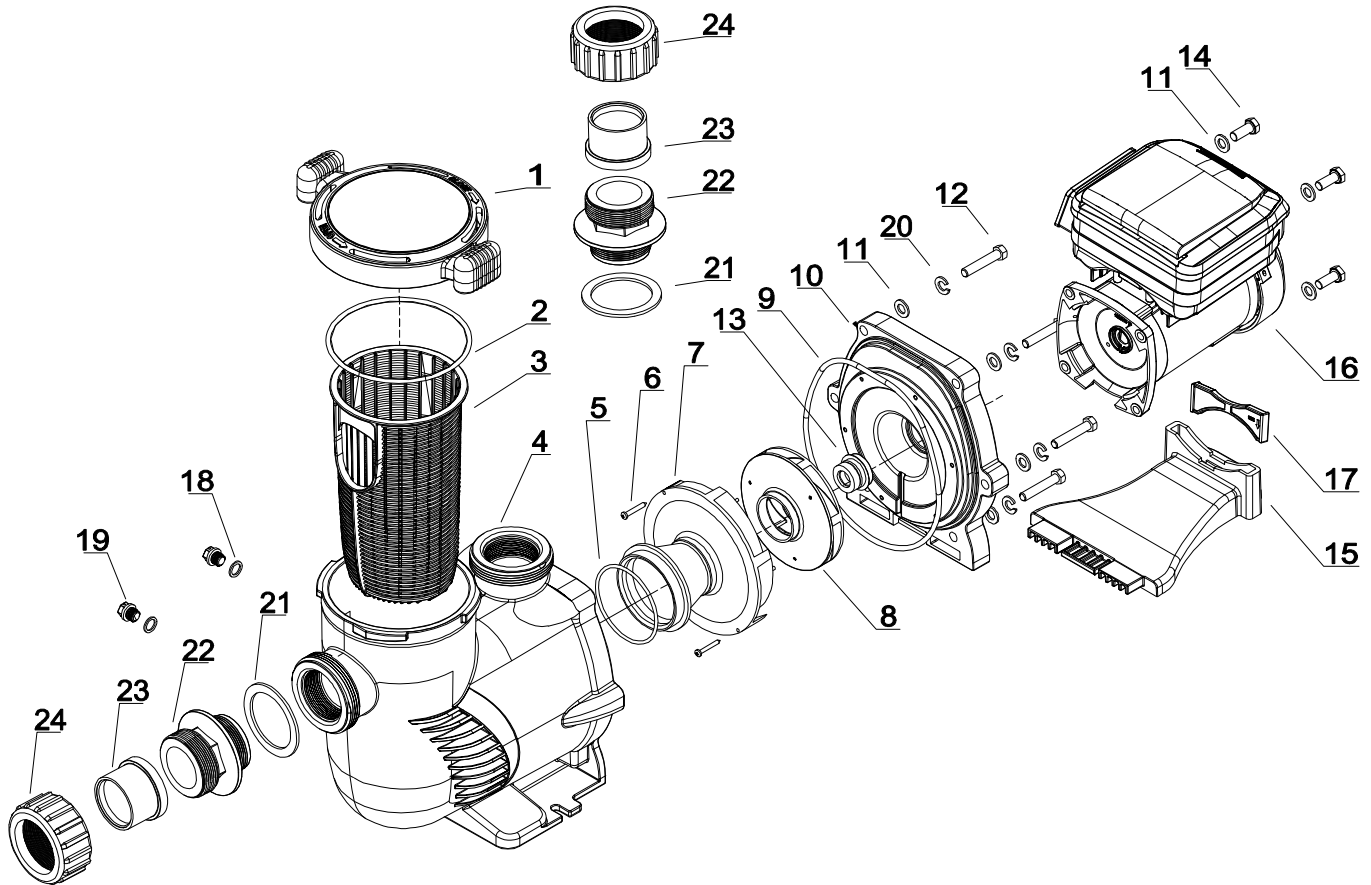

ITEM	PART NO.	DESCRIPTION	QTY
1	47276502	COVER	1
2	65431042080	O-RING $\phi 145^* \phi 5$	1
3	647276803001	BASKET	1
4	47276801	PUMP HOUSING	1
5	65431032080	O-RING $\phi 85.32^* \phi 3.53$	1
6	65212025000	SCREW ST4.2*38	2
7	647254703	DIFFUSER	1
8	647274871000	IMPELLER FOR 75408	1
9	65431045080	O-RING $\phi 196.22^* \phi 5.33$	1
10	647276802	PUMP COVER	1
11	65244015000	GASKET M10	16
12	65225012000	SCREW 3/8-16*1 1/2 UNC	6

ITEM	PART NO.	DESCRIPTION	QTY
13	65028014000	SEAL ASSEMBLY	1
14	65221008000	SCREW M10*25	1
15	65431042080	O-RING $\phi 145^* \phi 5$	1
16	65023520000	1.5HP MOTOR FOR 75408	1
17	647255302	SUPPORTING FOOT	1
18	65432002080	GASKET $\phi 19^* \phi 13^* \phi 1.57$	2
19	648860105	DRAIN PLUG	2
20	65244032000	SPRING WASHER M10	6
21	65432096080	GASKET $\phi 77^* \phi 59.5^* \phi 3$	2
22	647255503080	2" TO 1.5" ADAPTOR	2
23	649130101001	2" ADAPTOR	2
24	649130102001	2" NUT ADAPTOR	2

DISCLAIMER

DISCLAIMER

PLEASE READ THE FOLLOWING CAREFULLY

The manufacturer and/or distributor have provided the parts list and assembly diagram in this manual for reference purposes only. They do not make any representation or warranty to the buyer that they are qualified to make repairs to the product or replace any parts of the product. In fact, the manufacturer and/or distributor expressly state that all repairs and parts replacements should be undertaken by certified and licensed technicians, and not by the buyer.

The buyer assumes all risk and liability arising from their repairs to the original product or replacement parts or arising from their installation of replacement parts. It is strongly advised that qualified professionals handle any repairs or replacements to ensure safety and proper functioning of the product. Improper installation and operation may result in injury, property damage, or voiding of warranty. The manufacturer and/or distributor shall not be held responsible for any accidents, damages, or malfunctions resulting from the buyer's installation and operation of the product. It is essential to follow all safety guidelines and recommendations provided in this manual and to seek professional assistance if unsure about the installation or operation procedures.

CUSTOMER SERVICE

If you have any questions about ordering our pool pumps and replacement parts or pool products, please feel free to contact us using the following contact information:

Customer Service and Technical Support

Phone: (909) 628-0880

Email: customer@xtremepowerusa.com

Hours of Operation: Monday – Friday, 9AM – 4PM (CST)
