

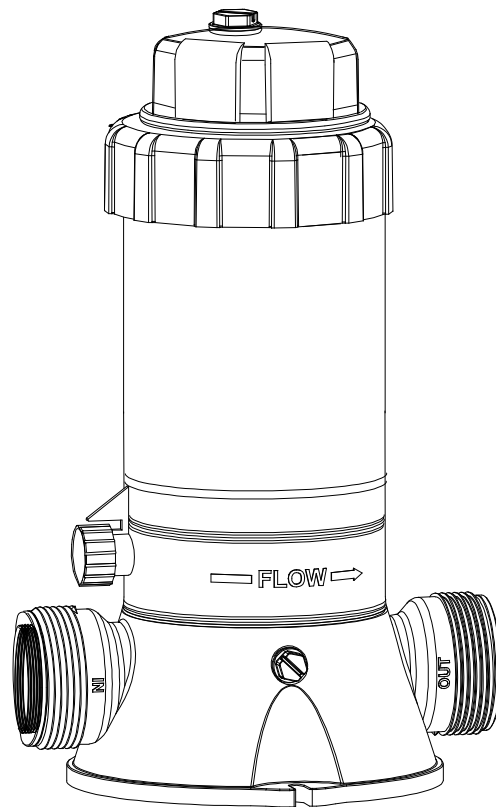

**AUTOMATIC CHLORINE FEEDER    SKU: 90157**  
**INLINE WITH CONTROL VALVE**



## ASSEMBLY AND USER'S GUIDE

**IMPORTANT:**

Review the instruction manual thoroughly before operating the machine.  
Keep it for future reference.

90157 

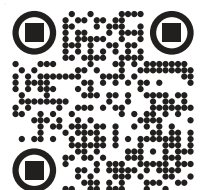



# TABLE OF CONTENTS

<b>TABLE OF CONTENTS</b> .....	<b>1</b>
<b>IMPORTANT SAFETY INSTRUCTIONS</b> .....	<b>2</b>
<i>Legends and Symbols</i> .....	2
<b>OVERVIEW (PRODUCT INFORMATION)</b> .....	<b>4</b>
PRODUCT INTRODUCTION .....	4
PRODUCT OVERVIEW .....	4
<b>INSTALLATION</b> .....	<b>5</b>
CHLORINE FEEDER CONNECTION .....	5
PLUMBING LINE CONNECTION .....	6
<b>OPERATION</b> .....	<b>7</b>
GENERAL USAGE .....	7
REFILL INSTRUCTIONS .....	7
<b>MAINTENANCE</b> .....	<b>8</b>
O-RING REPLACEMENT .....	8
FLOW CONTROL VALVE HANDLE REMOVAL .....	8
WINTERIZING .....	8
VACUUMING .....	8
LUBRICATION .....	8
<b>REPLACEMENT PARTS</b> .....	<b>9</b>
PARTS DIAGRAM .....	9
<b>DISCLAIMER</b> .....	<b>10</b>
<i>Disclaimer</i> .....	10
<i>Customer Service and Technical Support</i> .....	10

# IMPORTANT SAFETY INSTRUCTIONS

## IMPORTANT SAFETY INSTRUCTIONS

This guide provides instructions for installing and using the SPA AUTOMATIC CHLORINE FEEDER. If you have any questions about the equipment, please contact XtremepowerUS.

This guide contains important information about safely installing and operating this product. After installation, make sure to share this information with the owner/operator or leave it with them for their reference.

### *Legends and Symbols*

When you come across the safety-alert symbol on your equipment or in this manual, pay attention to the following signal words and remain vigilant about the potential for personal injury.

 **DANGER:** Ignoring these hazards can result in death, severe personal injury, or significant property damage.

 **WARNING:** Indicates potential hazards that can result in severe personal injury, death, or significant property damage. Ignoring these warnings presents a real danger.

 **CAUTION:** Indicates potential hazards that can result in minor or moderate personal injury, property damage, or actions that are unpredictable and unsafe. Ignoring these cautions presents a potential hazard.

 **NOTE:** This label indicates important special instructions that are not directly related to hazards.

---

### **USE OF NON-XTREMEPOWERUS REPLACEMENT PARTS VOIDS WARRANTY**

**ATTENTION INSTALLER:** This manual contains vital information regarding the installation, operation, and safe use of this product. It is essential to provide this manual to the end user of the product. Failure to read and follow all instructions could lead to severe injuries.

---

 **DANGER** Failure to comply with all instructions and warnings may lead to severe bodily injury or even death. For optimal safety and functionality, it is advisable to have the product installed and serviced by a certified service professional. Prior to using this product, installers, operators, and owners must carefully review these warnings and all instructions provided in the owner's manual. It is essential to leave these warnings and the owner's manual with the owner for their reference and safety.

 **WARNING** For safety reasons, children should not be allowed to use this product. Packing materials and plastic bags are not toys. Keep them away from children to prevent the risk of suffocation.

# IMPORTANT SAFETY INSTRUCTIONS

## **DANGER**

- **Improper Use:** Misusing this equipment or not following instructions can cause serious harm or damage.
- **Chemical Mixing:** Never mix different chemicals in the feeder.

## **WARNING**

- **Strongly Advised:** Ensure individuals are properly trained before operating or servicing this equipment.
- **Personal Protection:** Always use protective gear when handling chemicals.

## **CAUTION**

- **Chlorine Levels:** Do not exceed recommended chlorine levels.
- **Stable Setup:** Install the feeder on a stable surface.
- **Regular Checks:** Inspect and maintain regularly according to the manual.

## **NOTE**

- **Read First:** Review the manual thoroughly before use.
- **Ventilation:** Install in a ventilated area.
- **Proper Connection:** Ensure correct installation with the pool system.
- **Storage:** Keep chlorine in a cool, dry place, away from children and pets.
- **Emergency Plan:** Be aware of emergency procedures.

# OVERVIEW (PRODUCT INFORMATION)

## OVERVIEW (PRODUCT INFORMATION)

### PRODUCT INTRODUCTION

XtremepowerUS Automatic Chlorine Feeder with Flow Control Valve is the perfect addition to any pool maintenance setup. Engineered for efficiency and ease of use, it boasts a substantial 9 lbs capacity, reducing the need for frequent chlorine top-ups. The precision of the integrated flow control valve ensures the right amount of chlorine is released, keeping pool water pristine and swim-ready.

The Auto Off-Line Chlorine Feeder is designed for straightforward installation and effortless operation. It comes with all the necessary accessories, allowing for immediate setup and integration into existing pool systems. With this  $\beta$ , consistent water quality is seamlessly maintained, streamlining pool care and ensuring a superior swimming experience without the constant need for manual chlorine adjustment.

### PRODUCT OVERVIEW

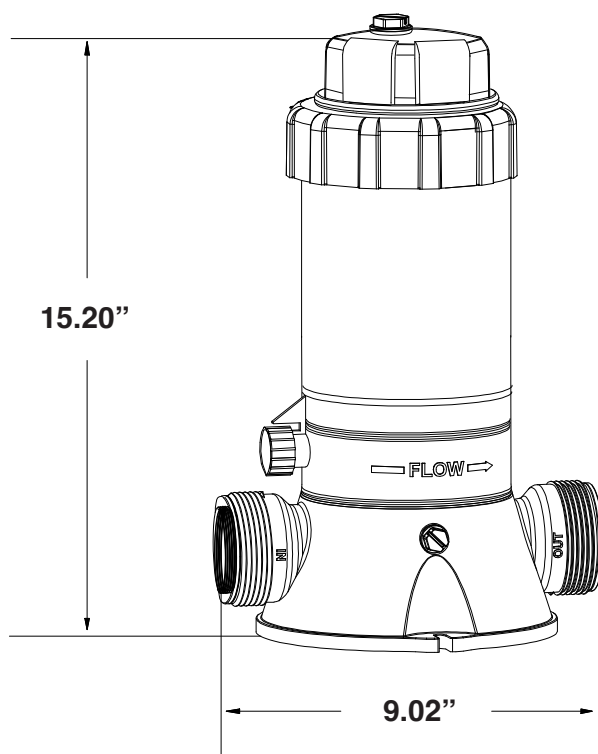

### SPECIFICATION

<b>CAPACITY</b>	9 LBS
<b>MAX. PRESSURE</b>	50 PSI
<b>MAX. OUTPUT</b>	32 LBS / HR

# INSTALLATION

## INSTALLATION

### ★ NOTE

- The AUTOMATIC CHLORINE FEEDER should be permanently installed in the pool's return water line.
- Install the chlorine feeder downstream of the heater. If no heater is present, install it after the filter. This prevents potential damage to the heater or filter from concentrated chlorine.
- The AUTOMATIC CHLORINE FEEDER comes with 1-1/2 inch threads. It also includes male threads. For male and union connections, please purchase the PVC male union connector package separately. Alternatively, thread or socket adapters can be used. Ensure to use only pipe sealants specifically designed for ABS plastic connections. Avoid overtightening pipe fittings; tighten by hand plus an additional 1 to 1-1/2 turns.
- After initiating the system, inspect all connections for leaks and tighten if necessary.
- Please refer to the "OPERATION" chapter for usage directions.
- Do not install the chlorine feeder directly into copper plumbing to avoid pipe damage. For systems with brass or bronze backwash valves or other sensitive metallic components, seek advice from your dealer for specific precautions and recommendations.

**FIGURE INSTALLATION & PIPING LAYOUT**

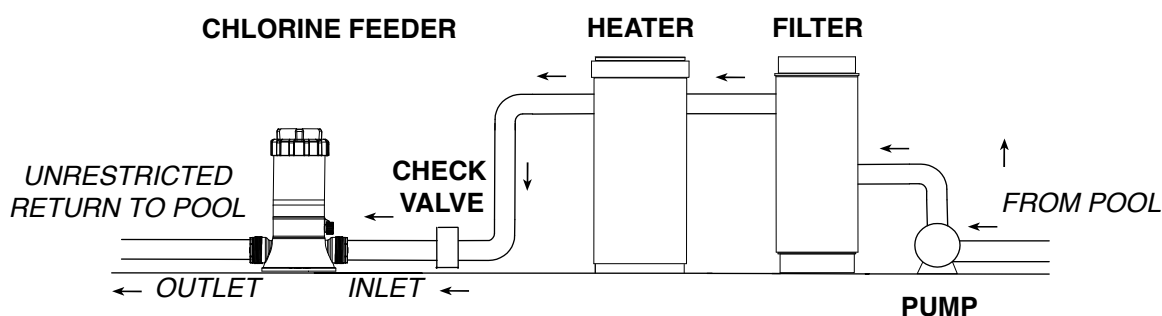

### ⚠ WARNING

Installation directly into copper plumbing is prohibited to prevent pipe damage. Systems with brass, bronze, or other metal components require a consultation with a professional for specific installation advice.

## CHLORINE FEEDER CONNECTION

- Apply Teflon tape to the Check Valve's larger male thread and fasten securely to the Chlorine Feeder's outlet.

### ★ NOTE

- Identify the Check Valve by the 'dot' marking and the clicking sound of the internal ball when shaken.

# INSTALLATION

## CHLORINE FEEDER CONNECTION (CONTINUED)

- Apply Teflon tape to the Check Valve's larger male thread and fasten securely to the Chlorine Feeder's outlet.
- Attach the inlet Fitting Adapter to the Chlorine Feeder's inlet with Teflon tape on its thread.
- For the inlet tubing, slide on a compression nut, insert tubing into the adapter fully, and tighten by hand to a secure fit without over-tightening.
- Attach the outlet tubing to the Check Valve as done with the inlet tubing.

## PLUMBING LINE CONNECTION

### NOTE

Saddle Fittings and clamps are intended for 1 1/2" or 2" outer diameter pipes.

- At the marked inlet point, drill a 3/8" hole and remove any burrs or shavings.
- Place the Saddle Fitting with its gasket into the hole and fasten with the clamp, ensuring a tight seal without over-tightening.
- Repeat the fitting installation for the outlet using the same steps as the inlet.
- Connect the inlet and outlet tubing to the Saddle Fittings using Compression Nuts and secure without excessive force.

### WARNING

After system activation, examine all connections for leaks and adjust if necessary to maintain a leak-free system.



## OPERATION

### GENERAL USAGE

- Balance and condition pool/spa water before Chlorine Feeder use.
- Maintain chlorine residual between 1.0 to 1.5 ppm.
- Monitor and adjust chlorine daily via the dial valve.
- Account for varying chlorine demand due to usage, temperature, and sunlight.
- Initially, determine proper chlorine amount and valve settings through trial.
- Follow chemical manufacturer's instructions for chlorine levels.

#### **DANGER**

- Only utilize 3-inch diameter slow-dissolving Trichloro-S-Triazinetrione Chlorine tablets.
- Fast-dissolving tablets of the same compound must not be used.
- Mixing chemicals can lead to fire or explosion.
- Avoid combining Trichloro-S-Triazinetrione Chlorine Tablets with Calcium Hypochlorite or any concentrated chlorine forms or chemicals.
- Do not introduce other chlorine types, pH adjusters, shock treatments, or algaecides into the skimmer. If necessary, apply these products directly to the pool water.
- Do not block the chlorine feeder with valves or other devices.

#### **WARNING**

- Follow all provided Safety Instructions when operating or servicing the Chlorine Feeder.
- To prevent injury, children should not use this product.
- Always wear protective eyewear and skin cover when performing maintenance or servicing.
- Do not breathe in vapors from the Chlorine Feeder or chemical containers.
- The Chlorine Feeder may be pressurized; exercise caution when removing the cover.

### REFILL INSTRUCTIONS

- Turn off all pumps and timers.
- Set the Chlorine Feeder's flow control valve to the "OFF" position.
- Ensure the return line to the pool from the Chlorine Feeder is free of obstructions.
- Wait one minute after turning off the system to allow for pressure release.
- Carefully remove the Chlorine Feeder cover.
- Restock the Chlorine Feeder exclusively with 3-inch slow-dissolving Trichloro-S-Triazinetrione Chlorine Tablets.
- Reattach and secure the Chlorine Feeder cover.
- Adjust the flow control valve to the required setting and reactivate the pump.

## MAINTENANCE

### O-RING REPLACEMENT

- Follow initial 5 steps from the Refilling Instructions.
- Use replacement O-Ring (Part# 65431036080), ensuring Slip Washers are properly placed on the Cover stem.
- If a refill is necessary, proceed with the final 3 steps of the Refilling Instructions.

### FLOW CONTROL VALVE HANDLE REMOVAL

- Position the pointer to FULL.
- Insert a screwdriver in the slot opposite the pointer, lift, and rotate the handle counterclockwise to disengage the handle index lock tab from the body ridge.

### WINTERIZING

- In areas with potential freezing temperatures, empty the Chlorine Feeder of water.
- For fixed in-line units, remove the drain plug.
- Take out any remaining tablets, rinse the Chlorine Feeder with water, and reattach the cover and drain plug.

### VACUUMING

- Shut the flow control valve during vacuuming to avoid sediment bypass and potential valve clogs.

### LUBRICATION

- Do not use petroleum-based lubricants on the Cover O-Ring.
- For lubrication, apply Jack's No. 327 lube exclusively.

# REPLACEMENT PARTS

## REPLACEMENT PARTS PARTS DIAGRAM

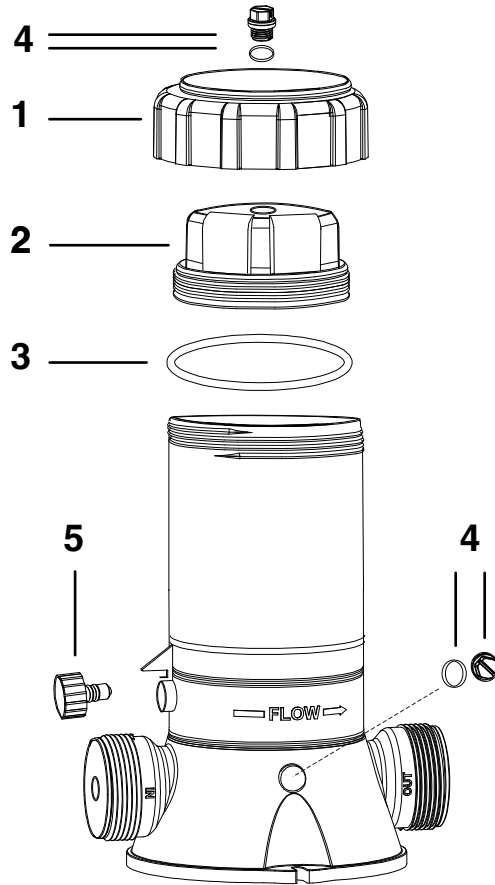

ITEM	PART NUMBER	DESCRIPTION	QTY
1	647016803080	COVER CAP	1
2	647016802000	COVER	1
3	65431036080	O-RING	1
4	88601004	DRAIN PLUG W/GASKET	2
5	647016875000	CONTROL VALVE ASSEMBLY	1

# DISCLAIMER

## DISCLAIMER

### ***PLEASE READ THE FOLLOWING CAREFULLY***

---

The manufacturer and/or distributor have provided the parts list and assembly diagram in this manual for reference purposes only. They do not make any representation or warranty to the buyer that they are qualified to make repairs to the product or replace any parts of the product. In fact, the manufacturer and/or distributor expressly state that all repairs and parts replacements should be undertaken by certified and licensed technicians, and not by the buyer.

The buyer assumes all risk and liability arising from their repairs to the original product or replacement parts or arising from their installation of replacement parts. It is strongly advised that qualified professionals handle any repairs or replacements to ensure safety and proper functioning of the product. Improper installation and operation may result in injury, property damage, or voiding of warranty. The manufacturer and/or distributor shall not be held responsible for any accidents, damages, or malfunctions resulting from the buyer's installation and operation of the product. It is essential to follow all safety guidelines and recommendations provided in this manual and to seek professional assistance if unsure about the installation or operation procedures.

---

## CUSTOMER SERVICE

If you have any questions about ordering our pool pumps and replacement parts or pool products, please feel free to contact us using the following contact information:

### ***Customer Service and Technical Support***

**Phone:** (909) 628-0880

**Email:** [customer@xtremepowerusa.com](mailto:customer@xtremepowerusa.com)

**Hours of Operation:** Monday – Friday, 9AM – 4PM (CST)

---