



REPLACEMENT SALT CHLORINATOR CELL

SKU:90160

15,000 GALLON

SKU:90161

25,000 GALLON

SKU:90162

40,000 GALLON

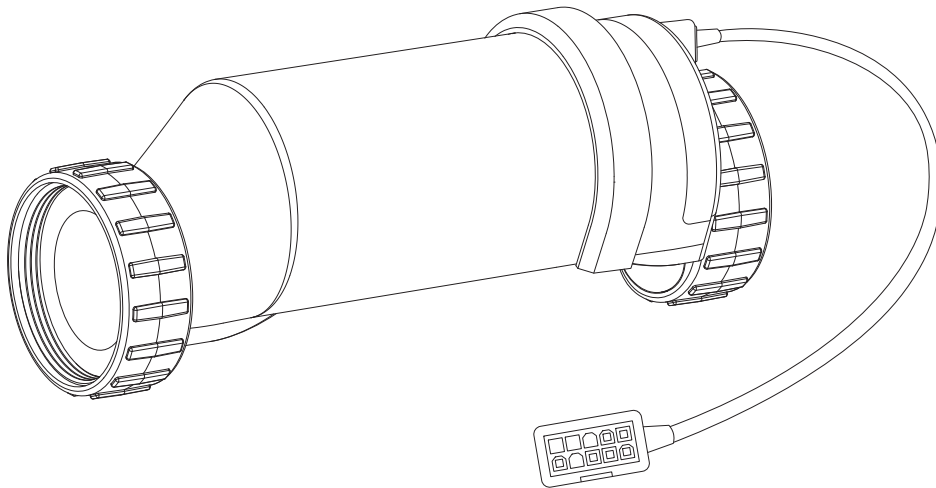

90160 

90161 

90162 

INSTALLATION AND USER'S GUIDE

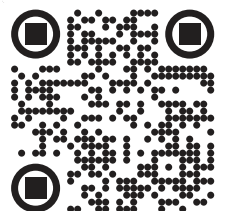

TABLE OF CONTENTS

TABLE OF CONTENTS	1
IMPORTANT SAFETY INSTRUCTIONS	2
<i>Legends and Symbols</i>	2
GENERAL SAFETY INFORMATION.....	3
PRODUCT INFORMATION	4
PRODUCT OVERVIEW.....	4
SPECIFICATION.....	4
INSTALLATION	5
INSTALLATION DIAGRAM.....	5
STEP 1.....	6
STEP 2.....	6
STEP 3.....	7
STEP 4.....	7
STEP 5.....	8
STEP 6.....	8
STEP 7.....	9
STEP 8.....	9
STEP 9.....	10
STEP 10.....	10
STEP 11.....	11
STEP 12.....	11
REPLACEMENT PARTS	12
REPLACEMENT PARTS.....	12
DISCLAIMER	13
<i>Disclaimer</i>	13
<i>Customer Service</i>	13

IMPORTANT SAFETY INSTRUCTIONS

IMPORTANT SAFETY INSTRUCTIONS

This guide provides instructions for installing and using the product. If you have any questions about the equipment, please contact XtremepowerUS.

This guide contains important information about safely installing and operating this product. After installation, make sure to share this information with the owner/operator or leave it with them for their reference.

Legends and Symbols

When you come across the safety-alert symbol on your equipment or in this manual, pay attention to the following signal words and remain vigilant about the potential for personal injury.

 **DANGER:** Ignoring these hazards can result in death, severe personal injury, or significant property damage.

 **WARNING:** Indicates potential hazards that can result in severe personal injury, death, or significant property damage. Ignoring these warnings presents a real danger.

 **CAUTION:** Indicates potential hazards that can result in minor or moderate personal injury, property damage, or actions that are unpredictable and unsafe. Ignoring these cautions presents a potential hazard.

 **NOTE:** This label indicates important special instructions that are not directly related to hazards.

USE OF NON-XTREMEPOWERUS REPLACEMENT PARTS VOIDS WARRANTY

ATTENTION INSTALLER: This manual contains vital information regarding the installation, operation, and safe use of this product. It is essential to provide this manual to the end user of the product. Failure to read and follow all instructions could lead to severe injuries.

 **DANGER** Failure to comply with all instructions and warnings may lead to severe bodily injury or even death. For optimal safety and functionality, it is advisable to have the product installed and serviced by a certified service professional. Prior to using this product, installers, operators, and owners must carefully review these warnings and all instructions provided in the owner's manual. It is essential to leave these warnings and the owner's manual with the owner for their reference and safety.

 **WARNING** For safety reasons, children should not be allowed to use this product. Packing materials and plastic bags are not toys. Keep them away from children to prevent the risk of suffocation.

IMPORTANT SAFETY INSTRUCTIONS

GENERAL SAFETY INFORMATION

DANGER

- High Voltage Electrocutation Hazard
- Hazardous voltage can shock, burn, cause serious injury, or death. To reduce the risk of electrocution and electric shock:
 - Only qualified technicians should remove the equipment.
 - Replace damaged wiring immediately.
 - Ensure the equipment is properly connected.

WARNING

- Electric Shock: Electrical wiring must follow local codes and NEC® standards.
- Child Safety: Do not allow unsupervised children to use this product.
- Temperature Impact: Higher temperatures may require more chlorine. Adjust based on factors like bather load, temperature, and debris.
- Gas Build-Up: Turn off the unit when adjusting plumbing valves to avoid hazardous gas build-up.
- Installation: Ensure pool materials are compatible with chlorine and salt. Operate the chlorine generator only when the pump is running.

NOTE

- Maintain proper pool chemistry at all times.

PRODUCT INFORMATION

PRODUCT INFORMATION

PRODUCT OVERVIEW

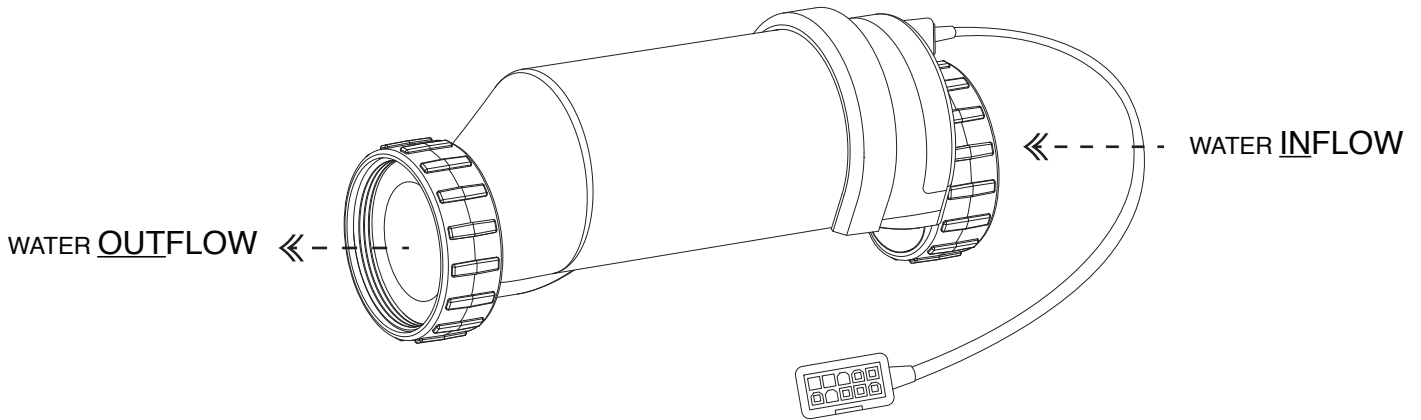

SPECIFICATION

MODEL / SKU #	90160	90161	90162
POOL CAPACITY	UP TO 15,000 GALLONS	UP TO 25,000 GALLONS	UP TO 40,000 GALLONS
CELL LIFETIME <i>(APPROX. 3 YEARS WITH 8-HOUR DAILY USE)</i>	10,000 HOURS	10,000 HOURS	10,000 HOURS
POWER CORD LENGTH	13.3 FT	13.3 FT	13.3 FT

INSTALLATION

INSTALLATION

INSTALLATION DIAGRAM

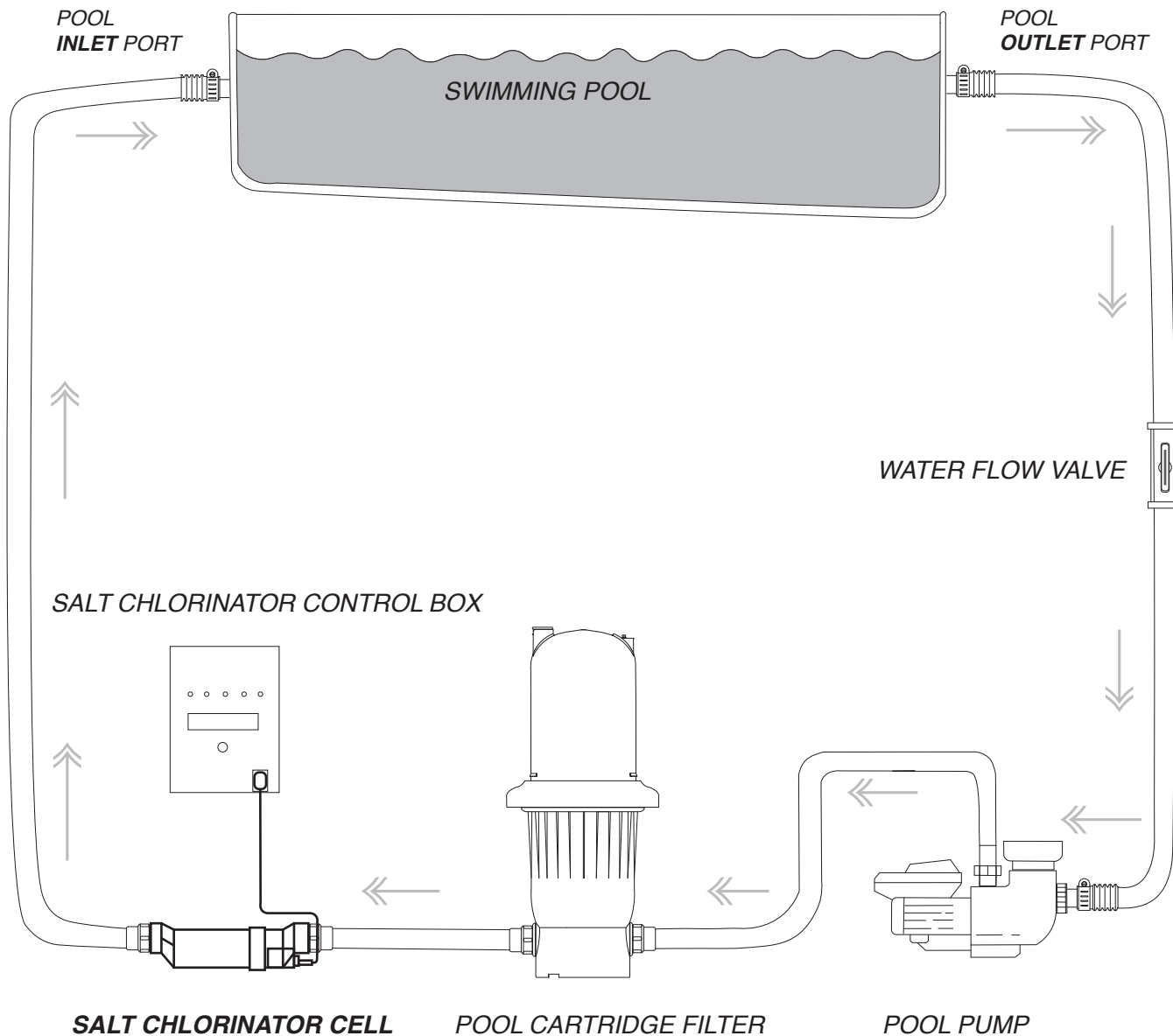

INSTALLATION

STEP 1

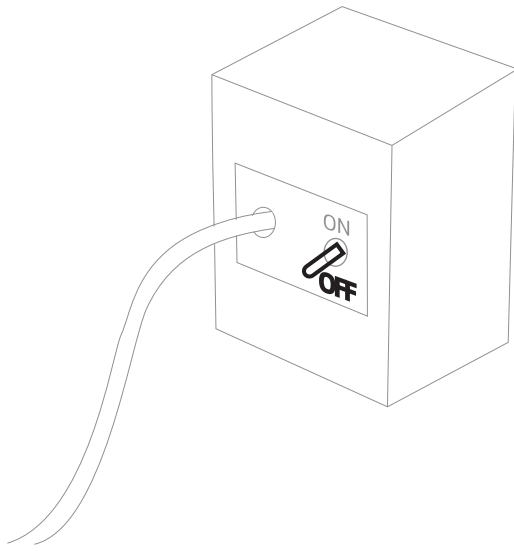

ELECTRIC POWER SOURCE

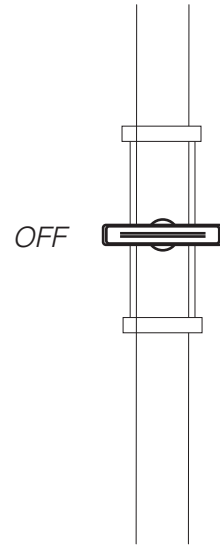

WATER FLOW VALVE

STEP 2

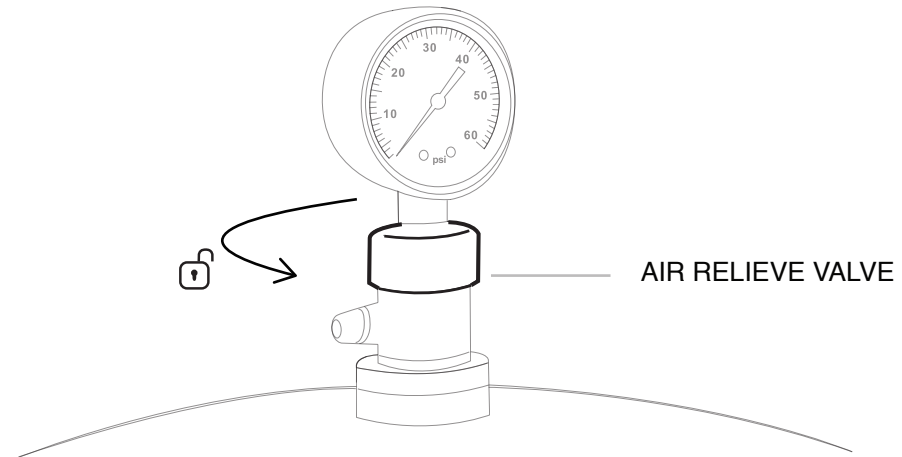

AIR RELIEVE VALVE

INSTALLATION

STEP 3

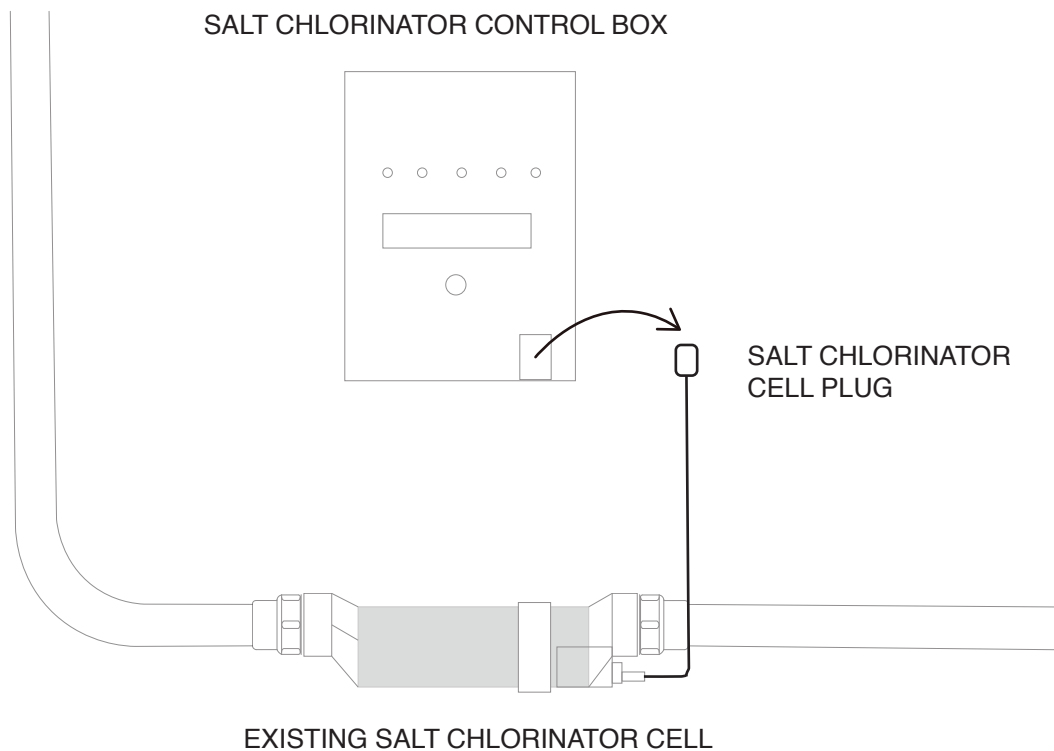

STEP 4

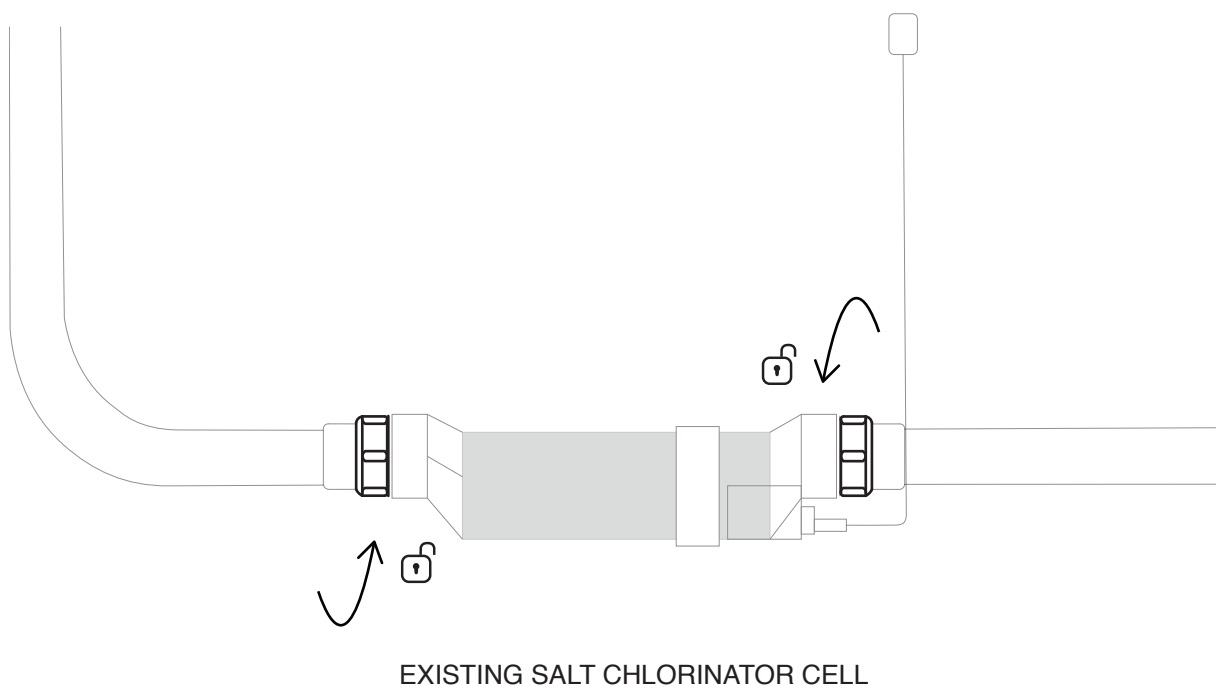

INSTALLATION

STEP 5

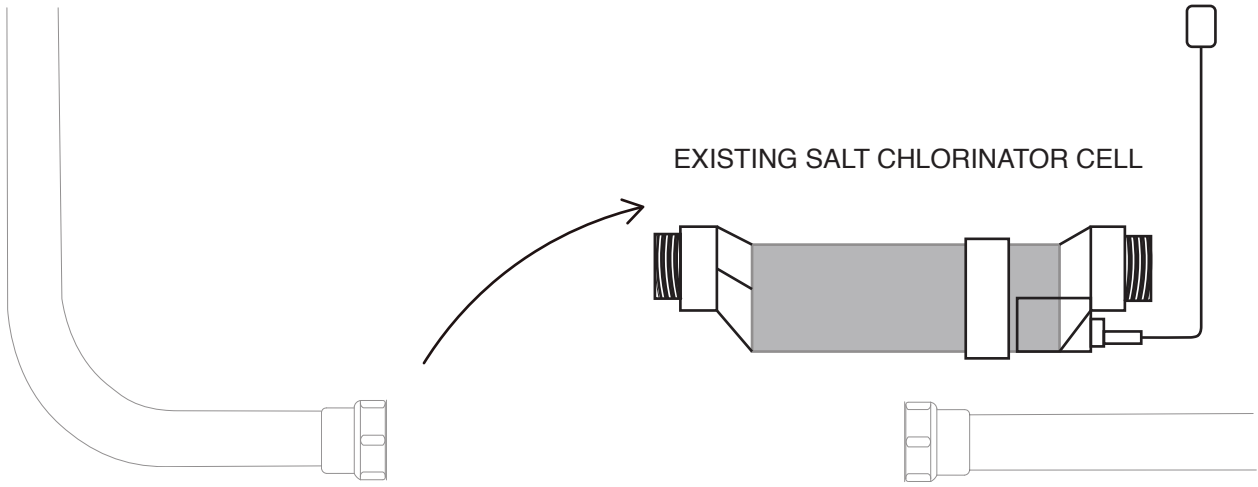

STEP 6

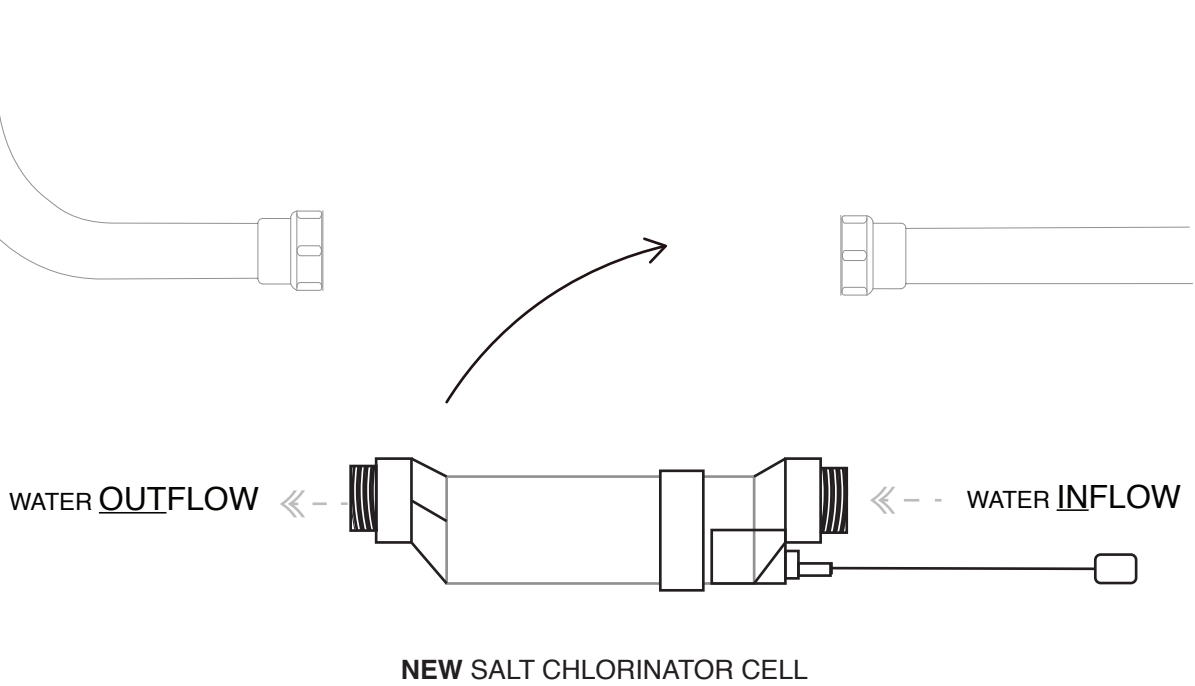

INSTALLATION

STEP 7

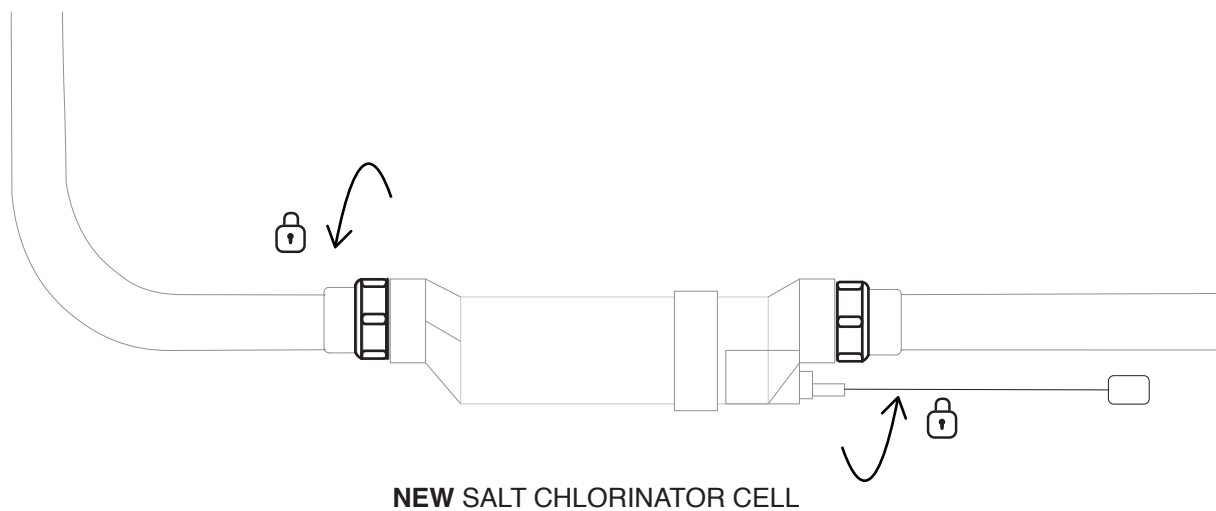

STEP 8

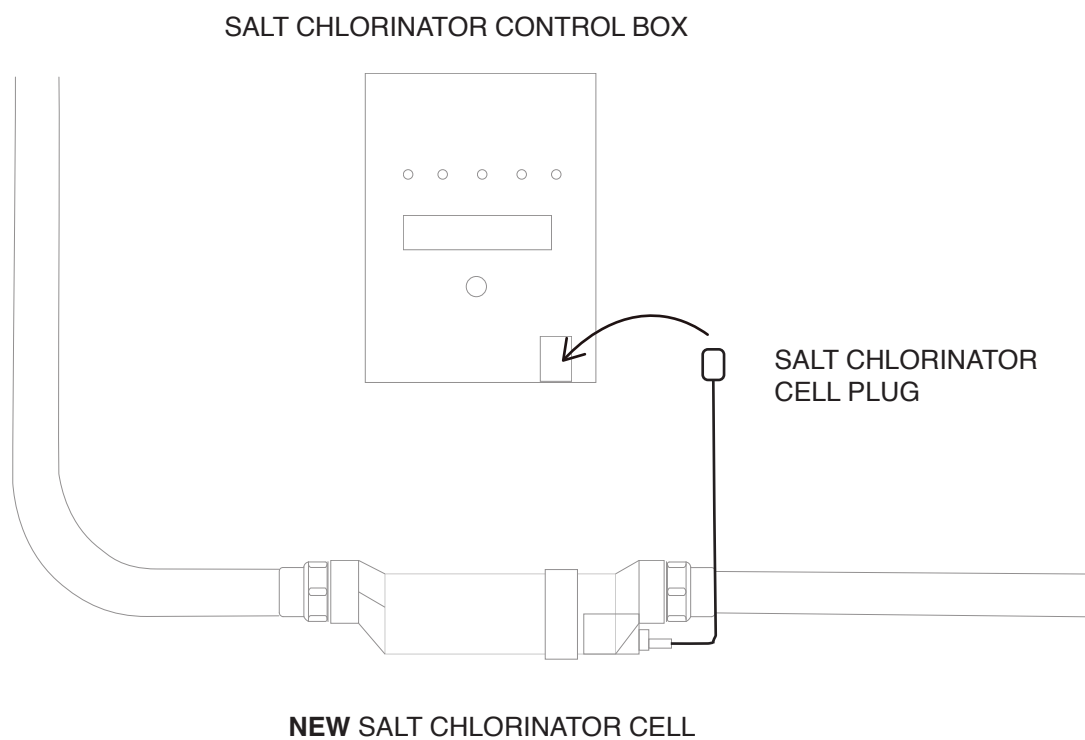

INSTALLATION

STEP 9



ON

WATER FLOW VALVE

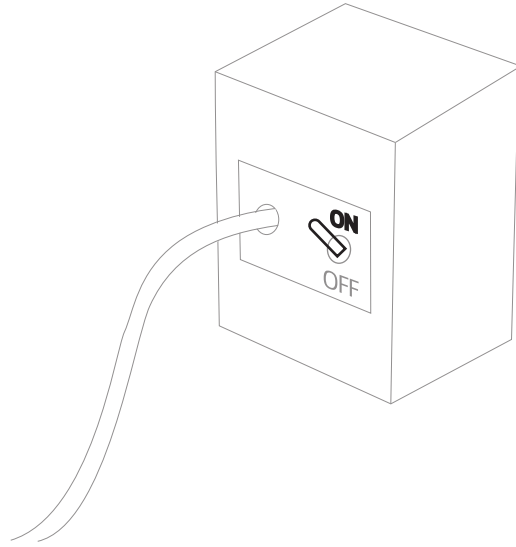

ELECTRIC POWER SOURCE

STEP 10

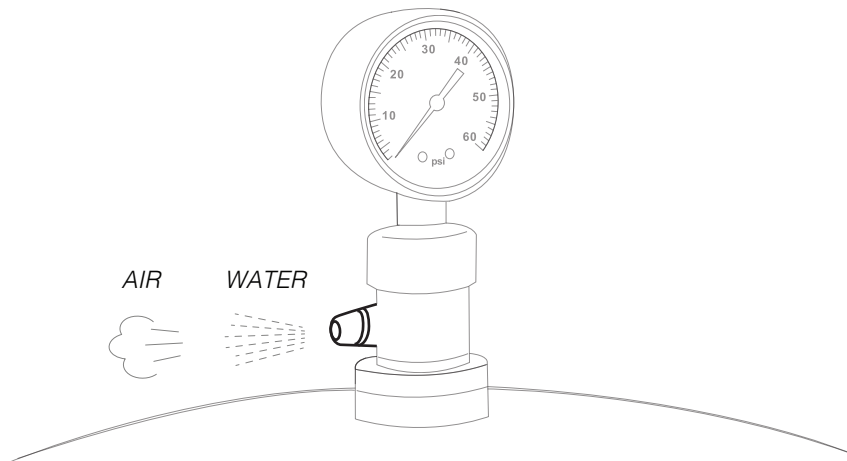

INSTALLATION

STEP 11

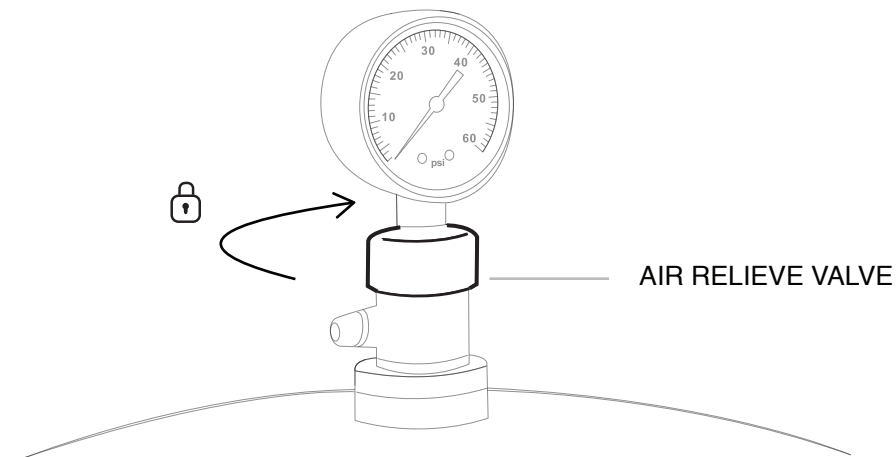

STEP 12



SALT CHLORINATOR CONTROL BOX

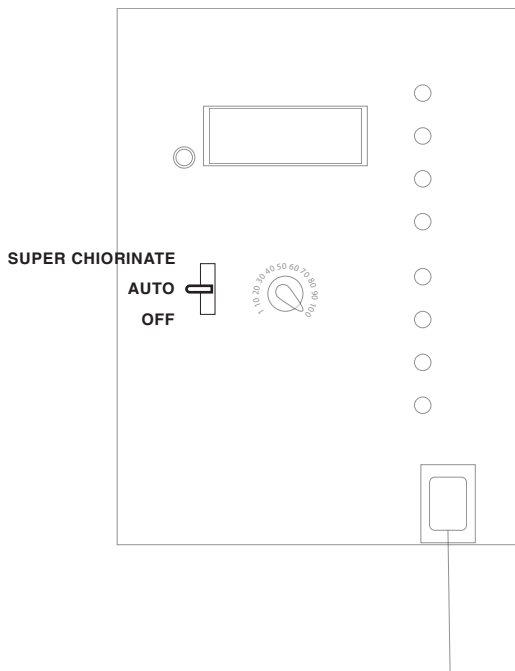

Calibrate Salt Reading:

- With the pump running, switch from "Auto" to "Off," then back to "Auto." Wait for the click.
- After the click, press the diagnostics button 5 times to start calibration.
- When the display matches the pool's salt level, switch to "Super Chlorinate," then back to "Auto."

INSTALLATION

REPLACEMENT PARTS

PARTS DIAGRAM

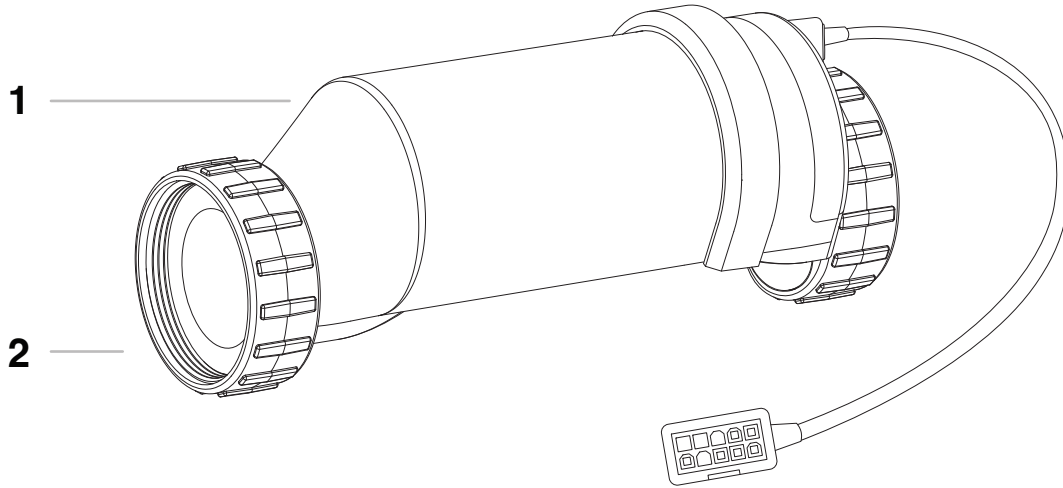

ITEM	DESCRIPTION	QTY
1	CELL BODY	1
2	UNION NUT <i>FIT 2" UNION SLIP</i>	2

DISCLAIMER

DISCLAIMER

PLEASE READ THE FOLLOWING CAREFULLY

The manufacturer and/or distributor have provided the parts list and assembly diagram in this manual for reference purposes only. They do not make any representation or warranty to the buyer that they are qualified to make repairs to the product or replace any parts of the product. In fact, the manufacturer and/or distributor expressly state that all repairs and parts replacements should be undertaken by certified and licensed technicians, and not by the buyer.

The buyer assumes all risk and liability arising from their repairs to the original product or replacement parts or arising from their installation of replacement parts. It is strongly advised that qualified professionals handle any repairs or replacements to ensure safety and proper functioning of the product. Improper installation and operation may result in injury, property damage, or voiding of warranty. The manufacturer and/or distributor shall not be held responsible for any accidents, damages, or malfunctions resulting from the buyer's installation and operation of the product. It is essential to follow all safety guidelines and recommendations provided in this manual and to seek professional assistance if unsure about the installation or operation procedures.

CUSTOMER SERVICE

If you have any questions about ordering our pool pumps and replacement parts or pool products, please feel free to contact us using the following contact information:

Customer Service and Technical Support

Phone: (909) 628-0880

Email: customer@xtremepowerusa.com

Hours of Operation: Monday – Friday, 9AM – 4PM (CST)
