



300FT HOSE REEL CART

ITEM: 96033



OWNER'S MANUAL AND SAFETY INSTRUCTIONS

SAVE THIS MANUAL: KEEP THIS MANUAL FOR SAFETY WARNINGS, PRECAUTIONS, ASSEMBLY, OPERATING, INSPECTION, MAINTENANCE AND CLEANING PROCEDURES. WRITE THE PRODUCT'S SERIAL NUMBER ON THE BACK OF THE MANUAL NEAR THE ASSEMBLY DIAGRAM (OR MONTH AND YEAR OF PURCHASE IF PRODUCT HAS NO NUMBER).

FOR QUESTIONS PLEASE CALL OUR CUSTOMER SUPPORT: (909) 628 0880 MON-FRI 9AM TO 3PM PST



GENERAL SAFETY WARNINGS

Read all safety warnings and instructions. Failure to follow the warnings and instructions may result in electric shock, fire and/or serious injury. Save all warnings and instructions for future reference.

SAFETY

The warnings, precautions, and instructions discussed in this instruction manual cannot cover all possible conditions and situations that may occur. It must be understood by the operator that common sense and caution are factors which cannot be built into this product, but must be supplied by the operator. Read carefully and understand all **ASSEMBLY AND OPERATION INSTRUCTIONS** before operating. Failure to follow the safety rules and other basic safety precautions may result in serious personal injury.

- **Read and understand all instructions.** Failure to follow all instructions may result in serious injury or property damage.
- **DO NOT** allow persons to operate or assemble the product until they have read this manual and have developed a thorough understanding of how it works.
- **Check for damaged parts before each use.** Carefully check that the product will operate properly and perform its intended function. Replace damaged or worn parts immediately. Never operate the product with a damaged part.
- **Keep children and bystanders away from the work area while operating the cart. DO NOT** allow children to handle the product.
- Stay alert, watch what you are doing, and use common sense when operating the tool. **DO NOT** use the tool while you are tired or under the influence of drugs, alcohol, or medication.
- **DO NOT** operate the tool if under the influence of drugs or alcohol. read the warning labels to determine if your judgment. If there is any doubt, **DO NOT** operate the tool.
- Keep work area clean, free of clutter and well lit. Cluttered and dark work areas can cause accidents.
- Keep children and bystanders away while operating the hose reel cart. Distractions can cause you to lose control, so visitors should remain at a safe distance from the work area.
- Be aware of all power lines, electrical circuits, water pipes and other mechanical hazards in your work area, particularly those hazards below the work surface hidden from the operator's view that may be unintentionally contacted and may cause personal harm or property damage.
- Be alert of your surroundings. Using the hose reel in confined work areas may put you in a dangerous situation.
- Dress properly. **DO NOT** wear loose clothing, dangling objects, or jewelry. Keep your hair, clothing and gloves away from moving parts. Loose clothes, jewelry or long hair can be caught in moving parts.
- **DO NOT** modify the hose reel cart in any way. Unauthorized modification may impair the function and/or safety and could affect the life of the equipment.
- **ALWAYS** check for damaged or worn out parts before using the hose reel cart. Broken parts will affect the hose reel cart operation. Replace or repair damaged or worn parts immediately.

PARTS and ASSEMBLY

Package Contents

Component	Description	Quantity
A	Frame	1
B	Wheels	4
C	Axles	2
D	Crank handle	1
E	Hose reel	1
F	Bearing fixed in bracket	1
G	Push handle	1
H	Accessories basket	1
I	Leader hose	1
J	Snap button fixed on push handle	2
K	Water inlet fixed on hose reel	1

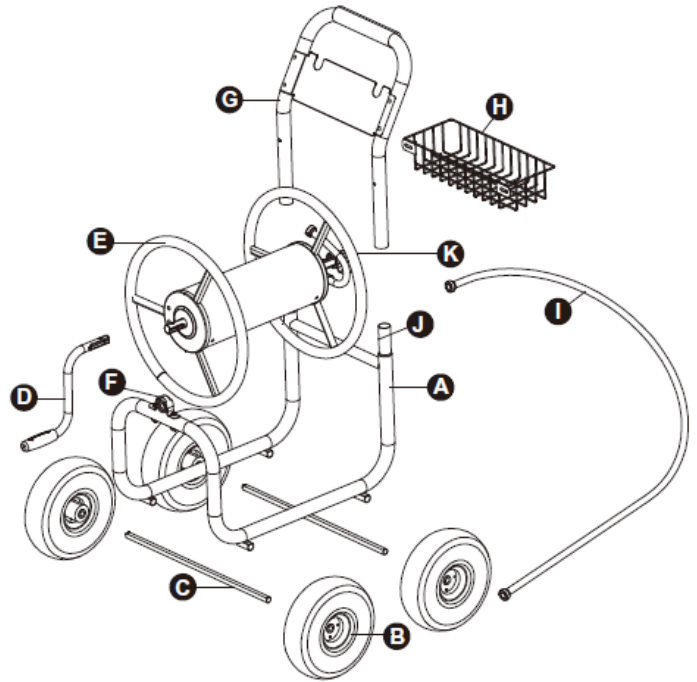

Hardware

Component	Description	Quantity
L	M6 x 40 Bolt	4
M	M6 Nylon nut	5
N	M6 Flat washer	5
O	M6 x 30 Bolt	1
P	M16 Flat washer	4
Q	Cotter pin	4
R	Phillips Head Screwdriver (Not included)	1
S	Adjustable Wrench (Not included)	1

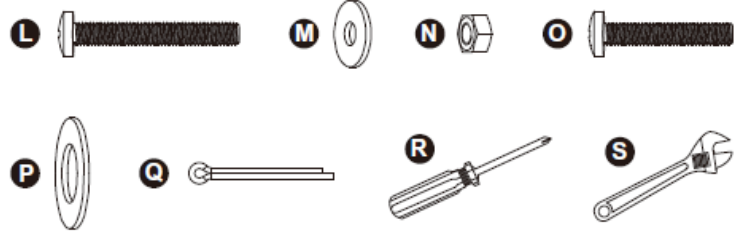

ASSEMBLY

Step 1 – Step 7

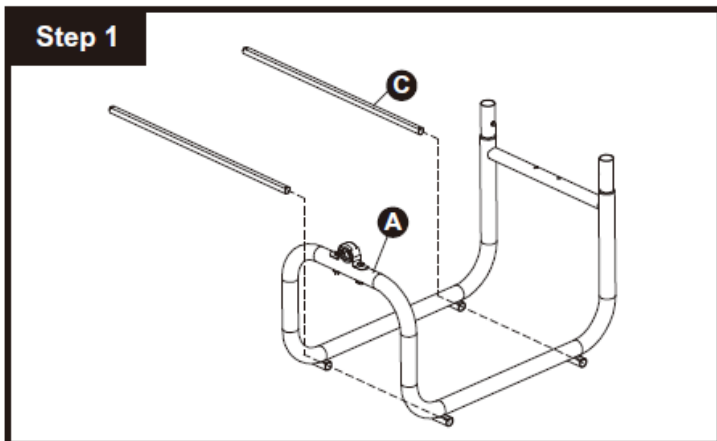

Insert two Axles(C) through the lower hole of Frame(A).

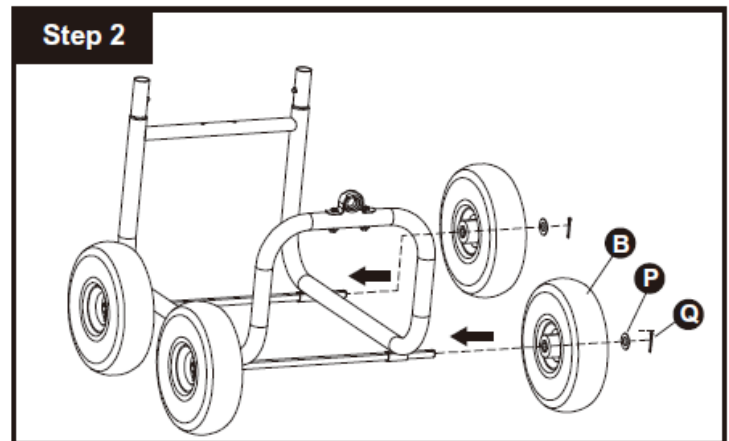

Assemble Wheels(B) on Axles(C) in the direction shown in the photo, put M16 Flat Washer(P), insert Cotter Pin(Q), use the long nose pliers(Not Included) to break open the Cotter Pin(Q). Repeat above to fix 4 Wheels.

ASSEMBLY

Step 3

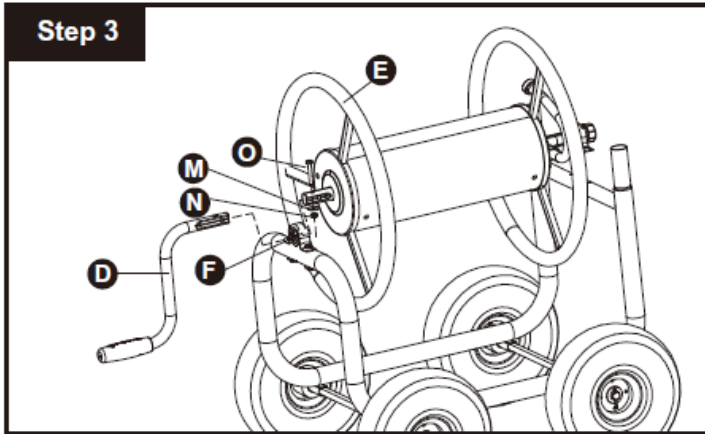

Assemble Crank Handle(D) through Bearing(F) into the shaft on Hose Reel (E).
Insert M6x30 Bolts(O), M6 Flat Washer(M) and M6 Nylon Nuts(N) into the shaft on Hose Reel(E), use Phillips Head Screwdriver(R,Not included) and Adjustable Wrench(S,Not included) to tighten them.

Step 4

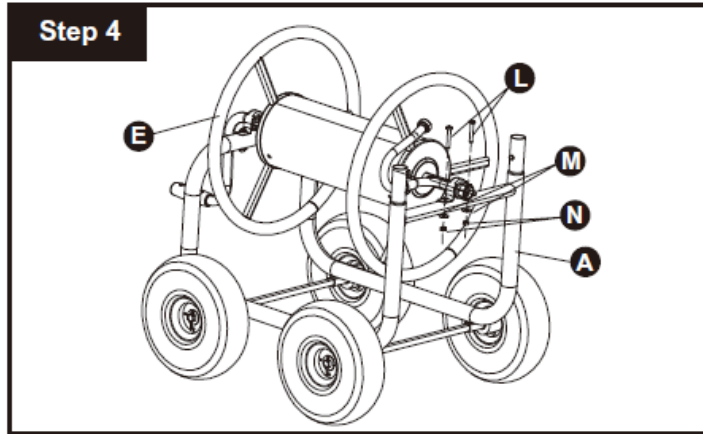

Assemble Hose Reel(E) on Frame(A) in the direction shown in the photo.
Insert M6x40 Bolts(L), M6 Flat Washer(M) and M6 Nylon Nuts(N) into the shaft on Hose Reel(E), use Phillips Head Screwdriver(R,Not included) and Adjustable Wrench(S,Not included) to tighten them.

Step 5

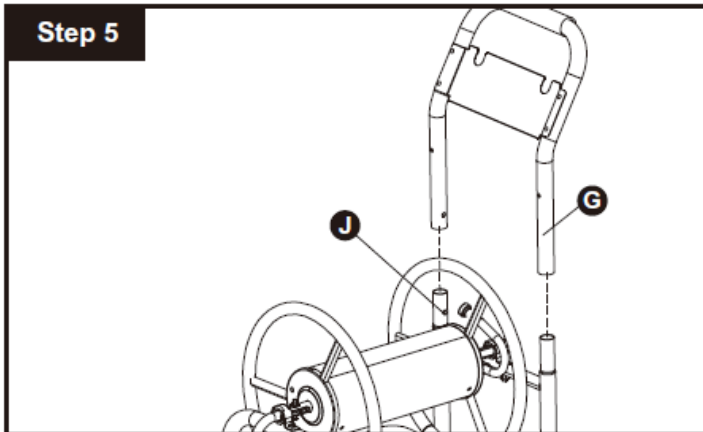

Insert Push Handle(G) into Frame(A) in the direction shown in the photo.
When Push Handle(G) touches the Snap Button(J), press the Snap Button(J) on both sides of Push Handle(G) and continue to insert Push Handle(G) until the Snap Button (J) pop up.

Step 6

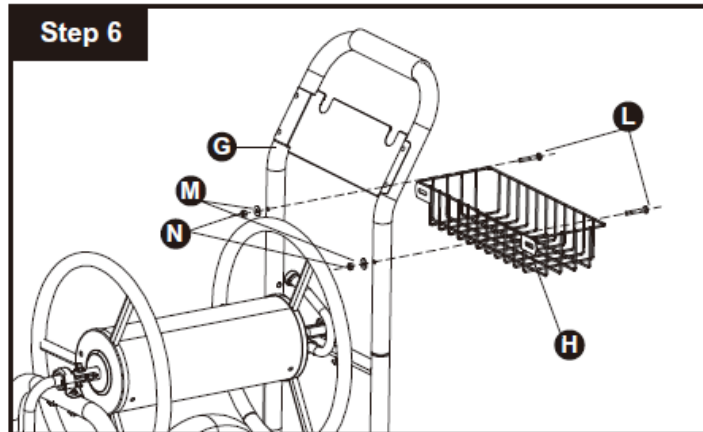

Assemble Accessories Basket(H) on Push Handle(G) in the direction shown in the photo.
Insert M6x40 Bolts(L), M6 Flat Washer(M) and M6 Nylon Nuts(N) into Push Handle(G), use Phillips Head Screwdriver (R,Not included) and Adjustable Wrench(S,Not included) to tighten them.

Step 7

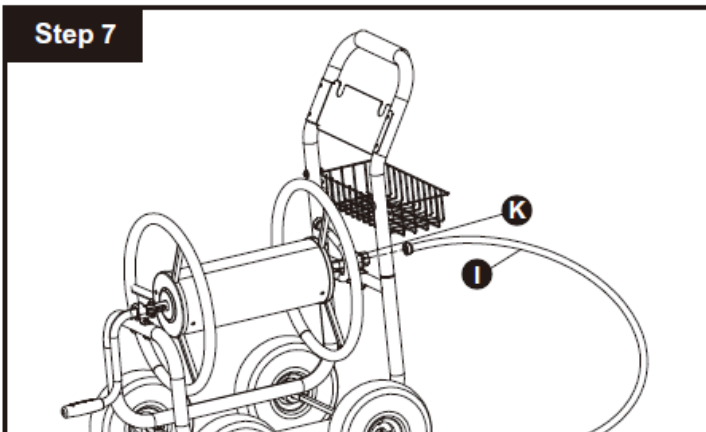

Screw Leader Hose(I) into Water Inlet(K) as shown in the photo and fully tighten it with Adjustable Wrench (S,Not included).

Troubleshooting

Fully tighten all bolts after product has been assembled. Periodically check bolts for looseness to prevent misalignment, wobbling or unsteady surface.

Care & Use Instructions

Wipe clean with damp cloth and dry before use.

Safety and Warranty Information

1. Please make sure all connections are ready before use
2. Don't use sharp item to break the product
3. Keep away from children

DISCLAIMER

PLEASE READ THE FOLLOWING CAREFULLY

THE MANUFACTURER AND/OR DISTRIBUTOR HAS PROVIDED THE PARTS LIST AND ASSEMBLY DIAGRAM IN THIS MANUAL AS A REFERENCE TOOL ONLY. NEITHER THE MANUFACTURER OR DISTRIBUTOR MAKES ANY REPRESENTATION OR WARRANTY OF ANY KIND TO THE BUYER THAT HE OR SHE IS QUALIFIED TO MAKE ANY REPAIRS TO THE PRODUCT, OR THAT HE OR SHE IS QUALIFIED TO REPLACE ANY PARTS OF THE PRODUCT. IN FACT, THE MANUFACTURER AND/OR DISTRIBUTOR EXPRESSLY STATES THAT ALL REPAIRS AND PARTS REPLACEMENTS SHOULD BE UNDERTAKEN BY CERTIFIED AND LICENSED TECHNICIANS, AND NOT BY THE BUYER. THE BUYER ASSUMES ALL RISK AND LIABILITY ARISING OUT OF HIS OR HER REPAIRS TO THE ORIGINAL PRODUCT OR REPLACEMENT PARTS THERETO, OR ARISING OUT OF HIS OR HER INSTALLATION OF REPLACEMENT PARTS THERETO.

Record Product's Serial Number Here: _____

Note: If product has no serial number, record month and year of purchase instead.

Note: Some parts are listed and shown for illustration purposes only and are not available individually as replacement parts.

The material in this manual is for informational purposes only. The product(s) it describes are subject to change without prior notice, due to the manufacturer's continuous development program. XtremePowerUS makes no representations or warranties with respect to this manual or with respect to the products described herein. XtremePowerUS shall not be liable for any damages, losses, costs or expenses, direct, indirect or incidental, consequential or special, arising out of, or related to the use of this material or the products described herein.

Questions, issues or missing parts?

Before returning to your retailer, our customer service team is here to help.



Call Us: 909.628.0880

Email Us: customer@xtremepowerusa.com

Hours of Operation: 9am - 3pm PST Monday - Friday

PRODUCT MADE IN CHINA